

## MODEL P610

Semi-Automatic Strapping Machine



### Features

- 30 cycles per minute
- $\frac{3}{8}$ " and  $\frac{1}{2}$ " wide polypropylene strapping
- Large variety of standard arch sizes
- Converts between  $\frac{1}{2}$ " and  $\frac{3}{8}$ " without parts
- Easy loading internal dispenser mount
- Self correcting arch feed system
- Electronic tension
- Palm switch, foot switch, and table ball switch
- Direct drive tensioning system for increased reliability
- Compact sealing head with fewer moving parts requires minimal maintenance

# Model P610

## Semi Automatic Strapping Machine

### Standard Features

The P610 series offers a unique combination of performance and affordability. The design of this machine utilizes the latest technologies in making it very operator friendly. The new "self-correcting" re-feed system can resolve mis-feeds quickly, without operator help, and continue strapping without losing valuable time.

The easy load strap dispenser tucks away neatly in it's internal cabinet drawer mounting, leaving the exterior of the machine cabinet compact in size.

The P610 features a sealing head with a compact design with fewer moving parts. It also has a completely electronic tensioning system with a direct drive tensioning wheel. These advanced features are designed to make the machine one of the most robust in its' class, reducing maintenance time and keeping your productivity high.

### Specifications

Strapping speed	30 cycles per minute
Minimum Package Size	3.5" wide x 3.5" high
Maximum Package Size	33" wide x 23" high
Maximum Package Weight	80 lbs
Strap Width	3/8" and 1/2"
Tensioning Range	6 to 150 ft/lbs
Power Supply	110V, Single Phase
Machine Weight	325 lbs
Shipping Weight	400 lbs
Machine Dimensions	43.75"(L) 21.75"(W) 58.25"(H)

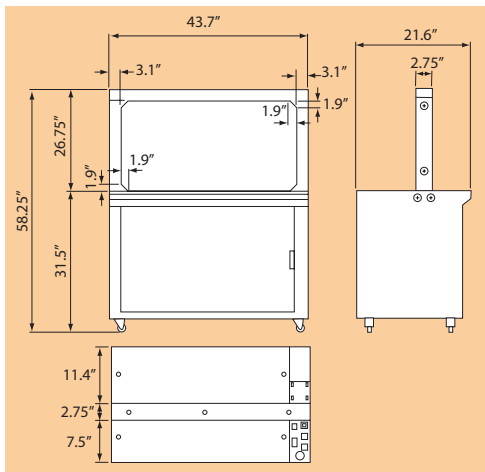

H \ W	23"	33"	41"	49"	57"	64"	72"	80"	88"	96"
15"	•	•	•	•	•	•	•	•	•	•
23"	•	S*	•	•	•	•	•	•	•	•
31"	•	•	•	•	•	•	•	•	•	•
39"	•	•	•	•	•	•	•	•	•	•
47"	•	•	•	•	•	•	•	•	•	•

\*standard arch size