

Dryomatic[®]

Model R-Series Dehumidifiers **Continuous Duty Air Dryers and** **Space Dehumidifiers** **Model R-150 & R-300 Dehumidifiers**



RELATIVE HUMIDITY

90%

80%

70%

60%

50%

40%

30%

20%

10%

WET BULB TEMPERATURES

160

140

120

100

80

60

40

20

Keeping Technology Dry

GRAINS OF MOISTURE PER POUND OF DRY AIR

Application

A continuous duty, rotating disc, atmospheric dryer designed primarily for both dynamic and static systems requiring low humidity control for industrial processes, critical storage areas and controlled environmental rooms. Ideally suited for use with precooling and/or aftercooling equipment to maintain total temperature-humidity control.

Design Benefits —

- Energy Efficient, High Water Removal Per KW Input
- Unitized Welded Steel Panels for Heavy Duty Integrity
- Non-toxic, Non-corrosive, Inert, Clinically Safe Desiccant
- Rotary Disc, Direct Drive System Provides Minimum Maintenance Part Replacement
- Minimum Leakage with Special Design Silicone Rubber Air Seals
- Process Air Draw-Thru Design
- Predictable Outlet Conditions
- Compact, Easy Access

Design Features —

- Process and Reactivation Blower Assembly Provides Centrifugal, Direct Driven, Open Drip Proof Motor Components
- Process and Reactivation Blower Assembly Provides Centrifugal, Direct Driven, Open Drip Proof Motor Components
- Electrical Controller Includes Motor Starters, Control Relays, and Overload Protection
- Industrial Duty Semi-Gloss Air Dried Enamel Finish
- Pre-Cooling, After-Cooling, and Re-Heat Assemblies Offered as Options
- Fully Insulated Interior

Performance Curves — Dryomatic® R Series

Moisture Removal

Example:

Assume 95 GR/# of air and 95°F entering condition to dehumidifier. Enter chart at 95 GR/# of air and extend vertically to intersect with 95°F curve, extend horizontally to left and read GR/# of air leaving dehumidifier.

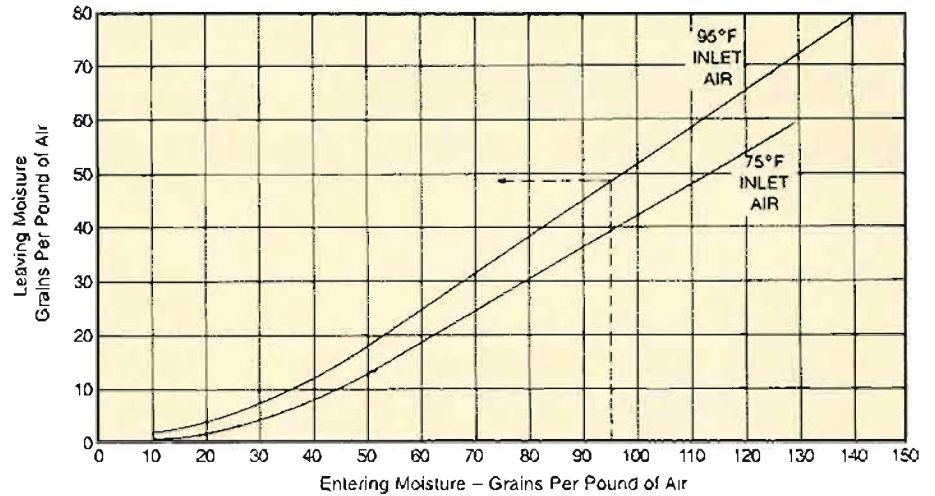

Leaving Air Temperature

Example:

Assume 95 GR/# of air and 95°F entering condition to dehumidifier. Enter chart at 95 GR/# of air and extend vertically to intersect with 95°F curve, extend horizontally to right and read temperature of air leaving dehumidifier.

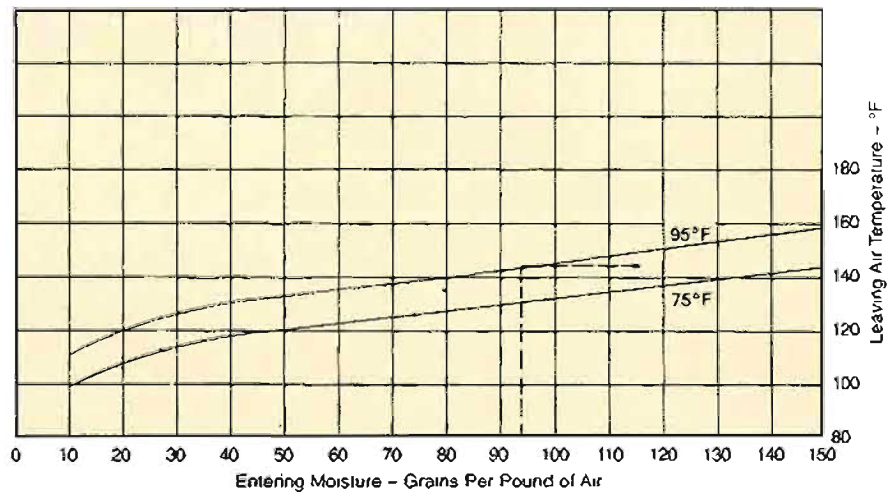

LEAVING AIR TEMPERATURE : °F FOR INLET TEMPERATURE BELOW 75°F.
SUBTRACT TEMPERATURE DIFFERENCE FROM OUTLET TEMPERATURE

Principle of Operation

The perforated metal desiccant bed, containing Silica Gel rotates clockwise at 3.19 RPH. The desiccant bed adsorbs moisture on the process side and is regenerated on the reactivation side of the unit on a continuous basis.

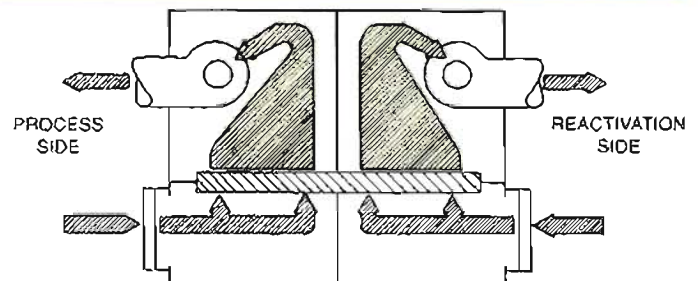

Wiring Diagram

Dryomatic®

WIRING STD. 208/220/3/60 4 WIRE

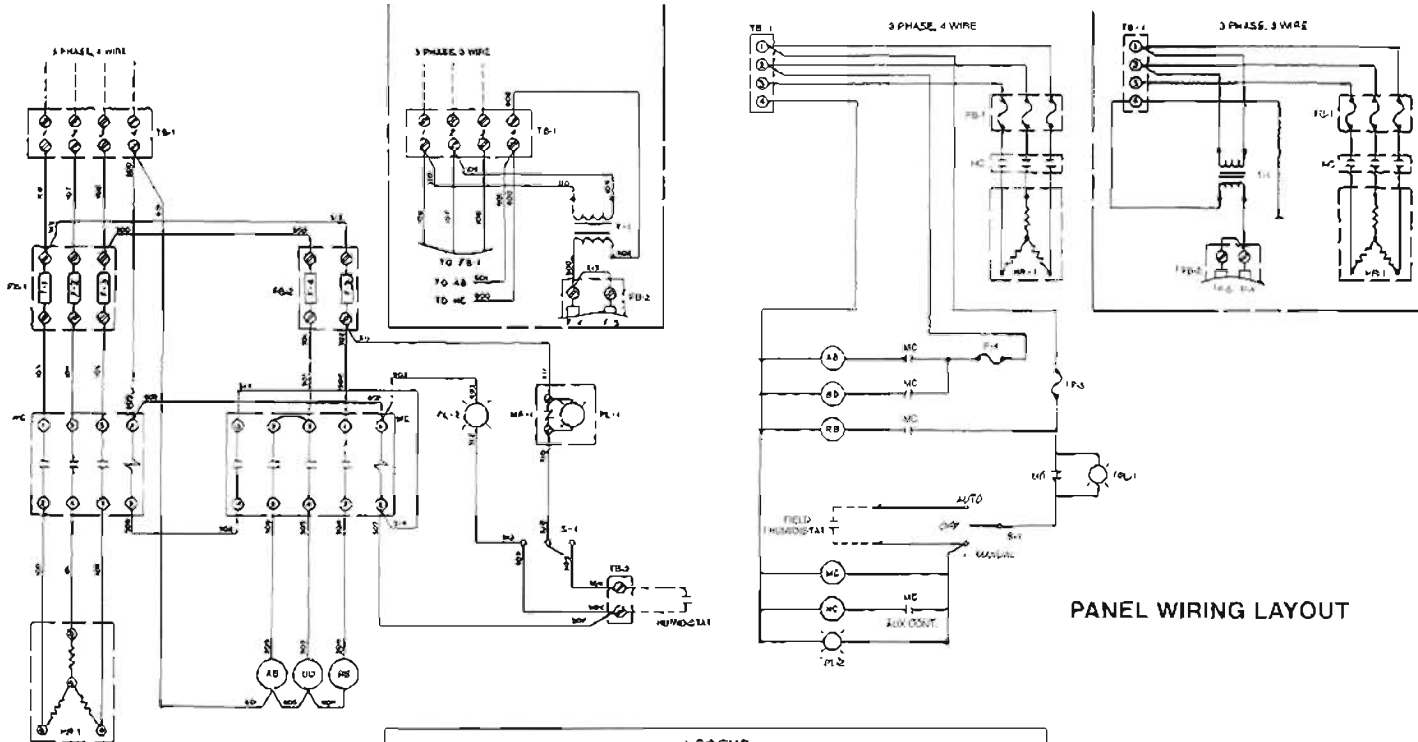

LEGEND

AB	ADSORPTION BLOWER MOTOR	PL-1	PILOT LIGHT MANUAL RESET
BD	BED DRYER MOTOR	PL-2	PILOT LIGHT UNIT ON
F-1,2,3	FUSE, HEATER	MC	MOTOR CONTRACTOR
F-4,5	FUSE, CONTROL CIRCUIT	RB	REACTIVATION BLOWER MOTOR
FB-1	FUSE BLOCK, HEATER	S-1	SWITCH, AUTO-OFF-MANUAL
FB-2	FUSE BLOCK, CONTROL CIRCUIT	T-1	TRANSFORMER, LINE VOLTAGE/120
VAC		TB-1	TERMINAL BOARD, POWER
HC	HEATER CONTACTOR	TB-2	TERMINAL BOARD, HUMIDISTAT
HR-1	HEATER		

Dimensions

MODEL R-150, R-300

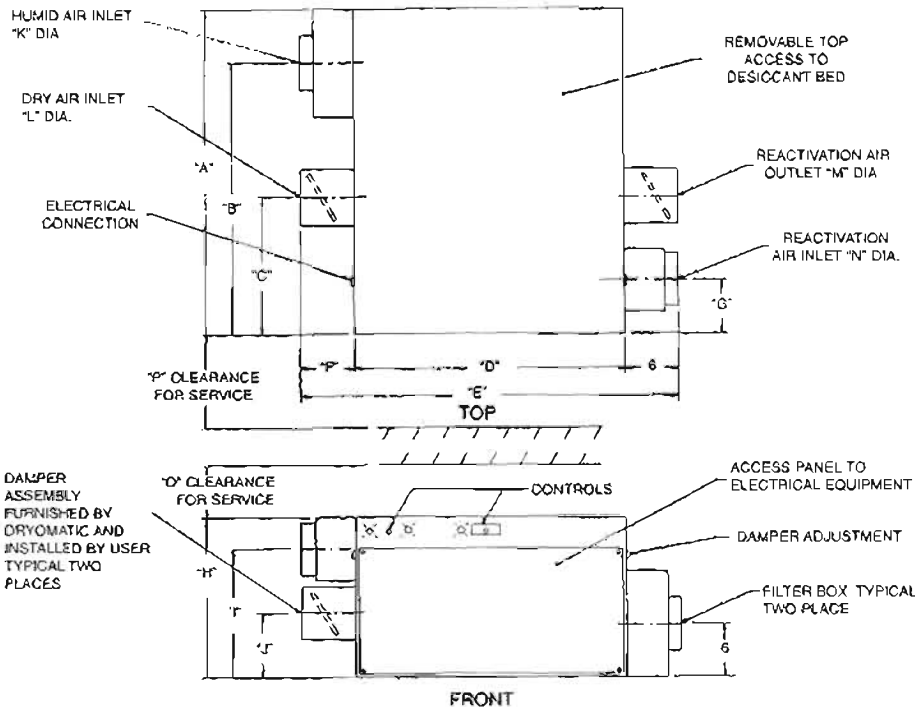

DIM	R-150	R-300
A	36	42
B	30	35-1/2
C	15-1/8	17
D	30	35
E	42	51
F	6	8
G	6	6-1/8
H	18	22
I	14-1/2	15-1/2
J	7-5/16	9
K	6	8
L	6	8
M	6	8
N	6	8
P	30	42
Q	18	22

Standard Specifications

Dryomatic® Model R-150

Electrical*:	Standard 208/220/3/60. 4 wire
Connected Load:	5.5 KW
Process Air Flow:	150 CFM @ .5" external static pressure
Reactivation Air Flow:	70 CFM @ .5" external static pressure
Seals:	Silicone rubber
Desiccant**:	28 lbs. non toxic, non corrosive 03 on 8 mesh, Dryomatic® standard silica gel
Insulation:	Reinforced, laminated fiberglass
Filter:	(2) 6" x 12" x 2" permanent washable filter, factory mounted
Damper:	(2) 6" diameter, single blade with duct mounting for field installation on both outlets
Manometer:	(1) U-tube manometer, 4" scale, with tubes and probes
Finish:	Industrial Gray
Operating Weight:	240 lbs.
Shipping Weight:	285 lbs. FOB Frederick, MD (factory)
Optional Accessory:	Humidistat

Dryomatic® Model R-300

Electrical*:	Standard 208/220/3/60. 4 wire
Connected Load:	10 KW
Process Air Flow:	300 CFM @ .5" external static pressure
Reactivation Air Flow:	140 CFM @ .5" external static pressure
Seals:	Silicone rubber
Desiccant**:	45 lbs. non toxic, non corrosive 03 on 8 mesh, Dryomatic® standard silica gel
Insulation:	Reinforced, laminated fiberglass
Filter:	(2) 12" x 12" x 2" permanent washable filter, factory mounted
Damper:	(2) 8" diameter, single blade with duct mounting for field installation on both outlets
Manometer:	(1) U-tube manometer, 4" scale, with tubes and probes
Finish:	Industrial Gray
Operating Weight:	300 lbs.
Shipping Weight:	350 lbs. FOB Frederick, MD (factory)
Optional Accessory:	Humidistat

* Other voltages and frequencies optional at extra cost.

** Activated alumina or molecular sieve available for special applications

Consult your nearest representative or the Dryomatic® Division of Airflow Company for additional application information. A wide range of other models of dehumidifiers are available for environmental control of humidity. Airflow Company also manufactures a full range of special purpose air conditioners for military and industrial applications and the DATAC line of air conditioners for data processing centers.

Due to Airflow Company's commitment to continued product improvement, data is subject to revision without notice

Your local Airflow Company representative:

Dryomatic®

DIVISION OF



Keeping Technology Dry

7924 Reco Ave. • Baton Rouge, LA 70814

Phone: (225) 612-7400

Fax: (225) 612-7407