



JONES

L200 Cartoner



Legend® Series

Legend® L200

Jones introduces the New Legend® L200

The L200 is the first of Jones' innovative Legend® Series of standard products. Pre-engineered configurations of these machines mean minimal customization which result in shorter lead times and lower cost solutions. This cartoner will be offered with pre-engineered product handling and transfer systems to meet a wide range of industry application requirements.

Key Features:

- Up to 200 cartons per minute
- Available machine centers 9" & 12"
- 8 weeks delivery
- Rotary carton feed, smooth belt driven
- Entirely servo driven
- Stainless steel welded tubular frame
- Tool-less transport lug replacement
- Color touch screen operator interface
- Machine mounted electrical enclosure
- Step-in guard door design
- Back pressure controlled high capacity carton magazine

Equipment Options:

- Overhead tamp system
- 4-gun gluing system
- Cycle stop flap closing system
- Open flap detect / reject system

Transfer Options:

- Rotary vane transfers with incline bag infeeds or with smart belt
- Overhead sweep (in-line or right-angle) with smart belt infeed

Machine Specifications:

- AB ControlLogix
- PLC PC Based HMI
- Nordson ProBlue 7 gluing system with 2 guns

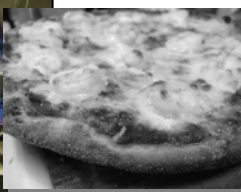
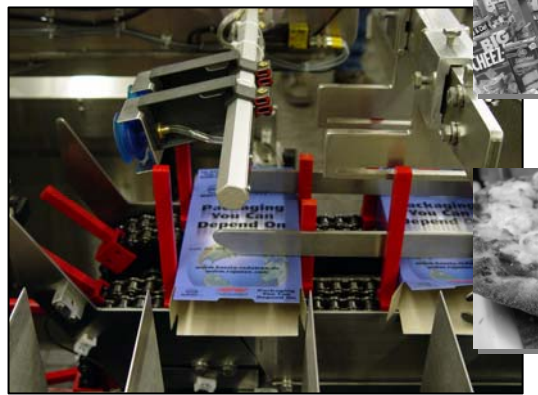
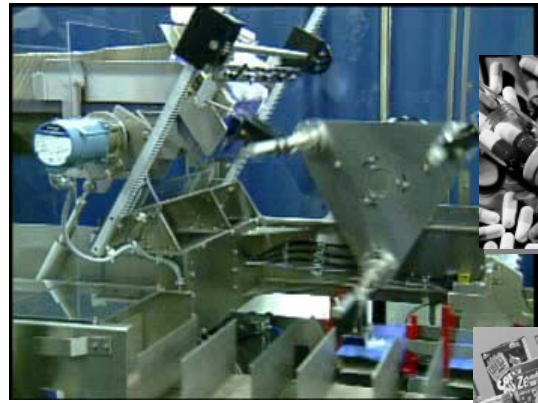

	Length		Width		Depth	
	Min	Max	Min	Max	Min	Max
9" Pitch	4.00" (102mm)	8.00" (203mm)	1.00" (25mm)	3.50" (89mm)	5.62" (143mm)	12.00" (305mm)
12" Pitch	4.00" (102mm)	11.00" (279mm)	1.00" (25mm)	3.50" (89mm)	5.62" (143mm)	12.00" (305mm)

Carton Styles



Standard



Frozen Food Tray



Standard

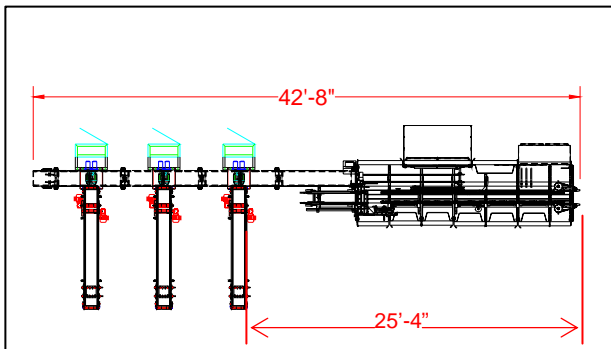

Rotary vane transfer and infeed system