

DRAGO 890

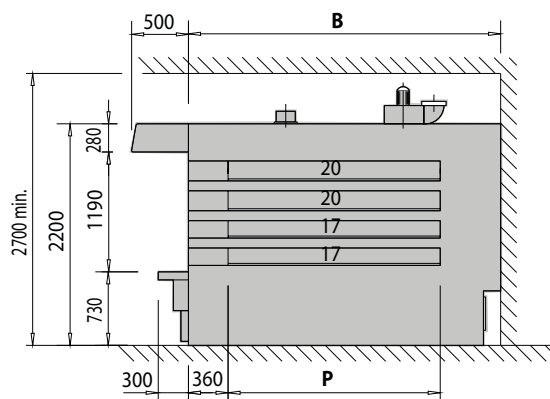

- N° 1 steamer for each deck (ovens width = 62 excluded: 1 steamer every 2 decks)
- Baking plates in "fibre-cement"
- Hood with exhaust fan
- Chimney silencer and soundproof panels in the bench
- Elettromechanic control board with reserve thermostat
- Safety thermostat
- Anticorrosion kit (i.e. Steam generators heads and connecting pipes)
- Safety devices in compliance with "CE" rules
- Doors with low emission dismountable glass

Power inlet	230/3~/50 400/3N~/50
Water inlet	Diameter 3/8" GAS
Steamer drain	Diameter 1" GAS
Steam exhaust output	Dr. 62 diameter 150 mm Dr. 124 diameter 200÷250 mm
Fume exhaust pipe	Diameter 150 mm

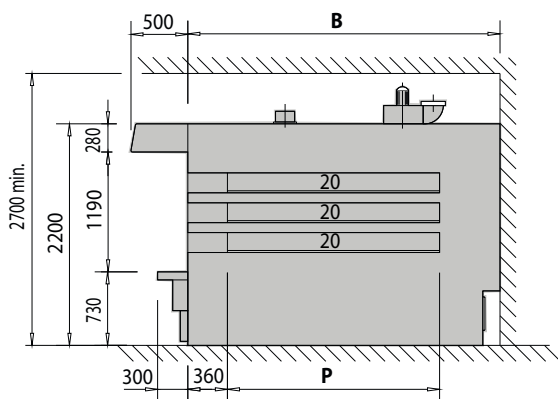

Mod. 62-4 Chambers

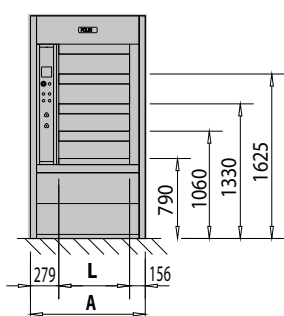

Mod. 124-3 Chambers

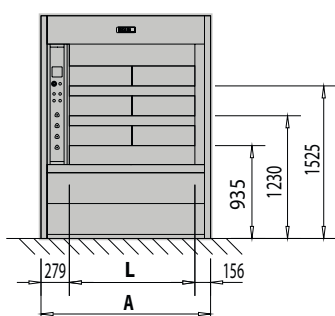

Mod. 124-4 Chambers

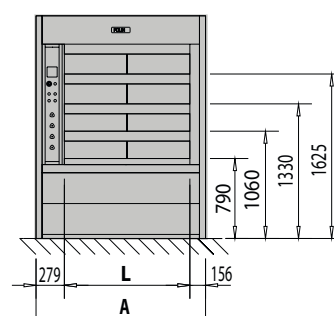

	Baking Surface	Chambers	Useful Dimension Chambers		Overall dimensions		Installed power	
			Width	Depth	Width	Depth	Thermic	Electrical
	mq	n°	L mm	P mm	A mm	B mm	kcal/hx1000	kW
4,2/62x170-4	4,2	4	620	1700	1055	2680	41	2,3
5,3/62x214-4	5,3	4	620	2140	1055	3120	45	2,3
6,4/62x258-4	6,4	4	620	2580	1055	3560	49	2,3
6,3/124x170-3	6,3	3	1240	1700	1675	2680	55	3,9
8,4/124x170-4	8,4	4	1240	1700	1675	2680	70	3,9
8,0/124x214-3	8,0	3	1240	2140	1675	3120	65	3,9
10,6/124x214-4	10,6	4	1240	2140	1675	3120	75	3,9
9,6/124x258-3	9,6	3	1240	2580	1675	3560	75	3,9
12,8/124x258-4	12,8	4	1240	2580	1675	3560	78	3,9