

BIRO®

MODEL 3334 POWER MEAT CUTTER OPERATING AND SERVICE MANUAL REVISED – SERIAL No. 1,000 ON

**SQ. BASE #35323 ON
FLAT TOP #35323 ON**

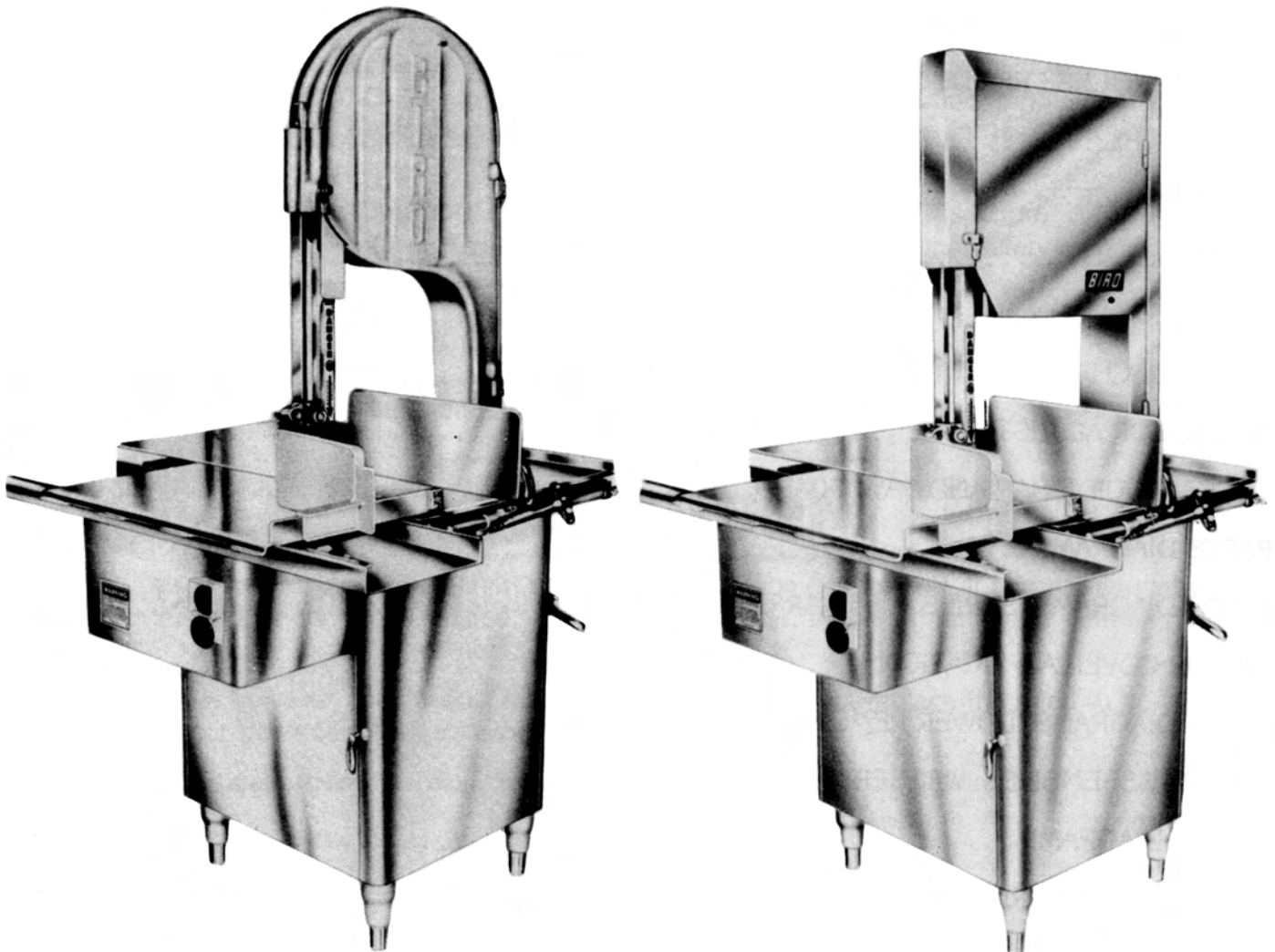

IMPORTANT NOTICE



This Manual contains important safety instructions which must be strictly followed when using this equipment.

TABLE OF CONTENTS

	Page
NOTICE TO OWNERS AND OPERATORS	1
SAFETY TIPS	2
INSTALLATION	3
WARNING LABELS	5
OPERATION	6
TO PROCESS PRODUCT	6 & 7
CLEANING	8
MAINTENANCE	9
GENERAL	9
LUBRICATION	10
WALL CHART (PART No. 671)	11
MOTOR ADJUSTMENT	12
SAW GUIDE BAR AND SAW GUARD	12 & 13
PARTS DIAGRAMS	14
PARTS DIAGRAMS, SERIES 4003 CARRIAGE & CHANNEL	21, 22, 23
NOTES	24
MOTOR COVER APPLICATIONS	25
PARTS DIAGRAMS, LOWER REMOVABLE WHEEL	25
SWITCH ASSEMBLIES AND SERVICE PARTS	26 & 27
WIRING DIAGRAMS	28, 29, 30
PARTS LIST/ORDERING	30 & 31
PARTS ASSEMBLIES LIST/ORDERING	32
STAINLESS STEEL HEAD STRUCTURE HISTORY	32
WEARABLE SAW PARTS	33
WARNING LABEL LOCATIONS ON MACHINE	34 & 35
NOTES	36
OPERATOR'S SIGNATURE PAGE	37
LIMITED WARRANTY	38

NOTICE TO OWNERS AND OPERATORS

BIRO's products are designed to process food products safely and efficiently. Unless the operator is properly trained and supervised, however, there is the possibility of a serious injury. It is the responsibility of the owner to assure that this machine is used properly and safely, strictly following the instructions contained in this Manual and any requirements of local law.

No one should use or service this machine without proper training and supervision. All operators should be thoroughly familiar with the procedures contained in this Manual. Even so BIRO cannot anticipate every circumstance or environment in which its products will be used. You, the owner and operator, must remain alert to the hazards posed by the function of this equipment – particularly the SHARP MOVING BAND TYPE SAW BLADE. No one under eighteen (18) years of age should operate this equipment. If you are uncertain about a particular task, ask your supervisor.

This Manual contains a number of safe practices in the SAFETY TIP section. Additional warnings are placed throughout the Manual. Warnings related to your personal safety are indicated by:



OR



Warnings related to possible damage are indicated by:



BIRO also has provided a wall chart to be posted near the equipment. If any warning label, wall chart, or Manual becomes misplaced, damaged, or illegible, please contact your nearest Distributor or BIRO directly for a replacement.

Remember, however, this Manual or the warning labels do not replace the need to be alert and to use your common sense when using this equipment.

This Manual applies to machines with serial number 1,000 and higher.

SAFETY TIPS

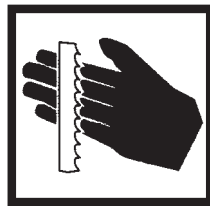

SHARP MOVING BAND TYPE SAW BLADE TO AVOID SERIOUS PERSONAL INJURY

NEVER Touch This Machine Without Training and Authorization By Your Supervisor.

ALWAYS Read Operation and Parts Manual **BEFORE** Operating, Cleaning or Servicing.

ALWAYS Keep Hands Clear of Sharp Band Type Saw Blade and Other Moving Parts.

ONLY Use a Qualified Electrician to Install According to Local Building Codes: Machines **MUST** Be Properly Grounded.

ONLY Install on Level, Non-Skid Surface in a Clean, Well-Lighted Area Away From Children and Visitors.

DO NOT Attempt to Operate This Machine Until it has Been Inspected and Demonstrated by the Seller – Recognized **BIRO** Representative.

DO NOT Alter or Modify This Machine in any Way From its Original Form. This Machine in its Original Form Meets the Intent of O.S.H.A. Applicable Standards.

NEVER Operate with Saw Guard on Saw Guide Bar in the Raised Position or the Saw Guard Removed from the Saw Guide Bar.

ALWAYS Adjust the Saw Guide Bar with Saw Guard to Within $\frac{1}{2}$ " of Product to be Cut.

ALWAYS Use Supplied Safety End Cut Pusher Plate for Smaller Products or The Last Cuts of Product.

DO NOT Use This Machine for Non-Food Products.

DO NOT Use This Machine to Cut Pigs Feet.

DO NOT Wear Gloves While Operating.

ALWAYS Turn Off, Unplug From Power Source and Perform Lockout/Tagout Procedure to This Machine **BEFORE** Removing Shrouds, Removable Guards, Covers, Doors, Fences or Panels for Cleaning, Servicing or Any Other Reason.

NEVER Leave Machine Unattended While Operating.

PROMPTLY REPLACE Any Worn or Illegible Warning Labels.

USE ONLY BIRO Parts and Accessories Properly Installed.

INSTALLATION



TO AVOID SERIOUS PERSONAL INJURY PROPERLY INSTALL EQUIPMENT IN ADEQUATE WORK AREA

ALWAYS Use Qualified Technician and Electrician for Installation.

ALWAYS Install Equipment in Work area with Adequate Light and Space.

ONLY Operate on a Solid, Level, Non-Skid Surface.

NEVER Operate with Saw Guard on Saw Guide Bar in the Raised Position or the Saw Guard Removed from the Saw Guide Bar.

ALWAYS Adjust Saw Guide Bar with Saw Guard to Within $\frac{1}{2}$ " of Product to be Cut.

NEVER Operate Without all Warning Labels Attached and Wall Chart Posted.

1. Read this Manual thoroughly before installation and operation. **Do not** proceed with installation and operation if you have any questions or do not understand anything in this Manual. Contact your local Distributor, or BIRO first.
2. Install machine on a level, solid, non-skid surface in a well-lighted work area away from children and visitors.



ALWAYS LEVEL MACHINE BEFORE USING

3. After installing machine in operational area, it is imperative that the four adjusting legs be adjusted to level the machine.
4. To assemble meat gauge plate (Part No. AS16275) to the machine; Loosen the lock knob (Part No. 272-7-1) on the right side of meat gauge bracket. Raise the meat gauge gear rack (Part No. S16272) and slip the meat gauge plate over the gear rack. Lower the gear rack back to its original position, tighten lock knob. Keep gear rack well oiled with food grade oil to ensure free movement.
5. The head structure (Part No. 16005) comes detached from the base. Slip the head into the slide gibs (Part No. 260) located on the back of the base structure. Make sure the slide gibs are oiled or greased to ensure free vertical movement of the head structure.

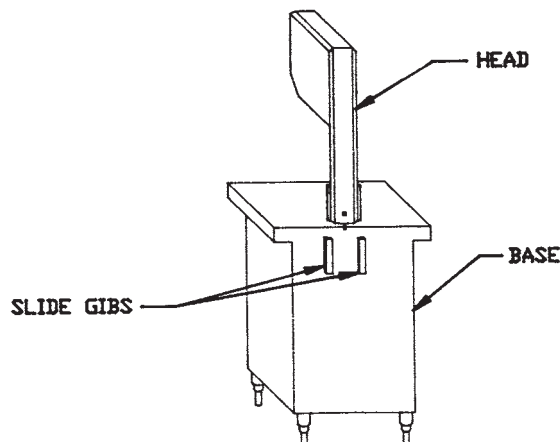

6. Place removable finger lift with saw guard assembly (Part No. A211) on the saw guide bar (Part No. 116-22) and fasten in place with finger lift fastener knob (Part No. 211A-291Q).



SHARP SAW BLADE. HANDLE WITH EXTREME CAUTION

7. Placing blade on cutter: Hang upper wheel assembly (Part No. A16003U335-6) on the hinge bracket (Part No. 71-1). lift the nylon filler (Part No. 177). Hang blade on the upper wheel and hold with right hand. With left hand force the back of the blade between the front blade cleaners (Part No. 131), located below the nylon filler. Lower the nylon filler and insert the back of the blade in the upper saw guide (Part No. 602B). The blade has already dropped over the lower wheel. With right hand force the back of the blade between the rear blade cleaners (Part No. 131). The blade is now ready to be tightened. Press down on the ratchet arm (Part No. 10-1) located at the rear of the base structure. Turn the upper wheel slowly by hand to ensure proper tracking of the saw blade on the wheels. Tighten to proper tension. When the tension gauge (Part No. 16197), located at the bottom rear of the head becomes tight laterally the blade is at proper tension.
8. The side platter bracket (Part No. S12214B) is packed loose in the machine and must be installed on the left side of the base structure with the supplied hardware and checked for proper adjustment. Stationary platter must be flat.
9. The stationary platter (Part No. A16163-1) is placed on top of the base structure and held in place by two push-pull hold down catches (Part No. 16212), located on the base structure.
10. The sliding meat carriage assembly (Part No. A16155) is installed by turning the movable stop assembly (Part No. A16200) clockwise. After the carriage assembly is in the channel for operation, turn the movable stop counterclockwise to lock.
11. Post SAFETY TIPS wall chart within easy view of operator. Keep Manual available to operator.
12. Machine **MUST** be properly grounded. Use qualified electrician to install according to building codes.

WIRING MOTOR

- (1) Interchange of current is made in motor outlet box. Leads are properly marked. Changing instructions are on motor plate or motor outlet box.
- (2) All cutters are wired 220 volts unless otherwise specified. Be sure motor specifications (voltage, cycle, phase) match power supply line. Be sure line voltage is up to specification.
- (3) Connect leads to machine in a manner that will be approved by local electrical inspectors.
- (4) We recommend no less than No. 12 wire. If the leads are too light, machine may not have sufficient cutting power and/or speed.
- (5) The drive belt is packed loose in machine to prevent deformation, and must be installed on pulleys at time of wiring motor.
- (6) The BIRO Manufacturing Company is not responsible for permanent wiring, connection or installation.



NOTE TO OWNER AND ELECTRICIAN: IF THIS MACHINE IS NOT CORD AND PLUG CONNECTED TO THE ELECTRICAL SUPPLY SOURCE, THEN IT SHOULD BE EQUIPPED WITH, OR CONNECTED TO, A LOCKABLE, MANUALLY OPERATED DISCONNECT SWITCH (OSHA 1010.147).



KEEP HANDS CLEAR OF SHARP MOVING BAND TYPE SAW BLADE

13. Make sure saw guide bar with saw guard is in its lowest position. Close head and base doors.
14. Push start button and check for proper phasing of motor. Blade should be traveling down through saw guide.
15. Watch for proper tracking of blade. Back of blade should be centered in hole in saw guide in stationary bar (Part No. 119A). Push stop button to stop machine.
16. Check placement of all warning labels, wall chart and Manual. Machine is ready for trained operators to process product.
17. Contact your local Distributor or BIRO directly if you have any questions or problems with the installation or operation of this machine.

WARNING LABELS FOR BIRO POWER MEAT CUTTERS SEE PAGE 32 AND 33 FOR LOCATIONS ON MACHINE



WARNING



DO NOT Use Unless Trained and Authorized By Supervisor And Over 18 Years Old.
Read Operation Manual Thoroughly Before Operating.
ALWAYS Keep Hands Clear of Saw Blade and Other Moving Parts. Turn Off Saw when Finished Cutting.
ALWAYS Keep Blade Guard Adjusted to 1/2" Above the Product being Cut.
ALWAYS Use End Cut Pusher Plate When Cutting Smaller Piece of Product.
DO NOT Use Saw if it is Altered, Damaged, Improperly Maintained, or If Warnings Are Illegible or Missing.
ALWAYS Disconnect and Unplug from Main Power Source and Perform LOCKOUT/TAGOUT Before Cleaning or Servicing.

#653PC-E

Item No. 653PC-E



MUCHO CUIDADO



NO Opere Esta Sierra Sin Haber Sido Entrenado Para Ello Ni Tampoco Sin Autorizacion de un Supervisor. Uno Tiene que Haber Cumplido 18 Anos Para Operarla.
LEA Cuidadosamente el Manual de Operacion Antes de Usar Este Equipo.
SIEMPRE Guarde las Manos a Salvo de la Hoja de Serrar y de Otras Partes Moviles. Cirre el Interruptor Despues de Terminar de Cortar.
SIEMPRE Tenga Ajustado el Guardasierra Para que Quede a 1/2" Por Encima del Producto que se Corta.
SIEMPRE Haga Uso de la Placa de Empuje Para Cortes de Extremos al Cortar Trocitos Pequeños.
NO Utilice la Sierra si se Halla Alterada, Danadao si No ha Sido Debidamente Mantenido o si la Advertencia es Alegible o si Falta Esta.
SIEMPRE Desconecte el Equipo Decenchifandolo de la Fuente de Fuerza. Dejelo Bajo Llave o con Etiqueta que Prohiba su Uso Antes de Limpiarlo o Hacer Trabajos de Mantenimiento.

#653PC-SP

Item No. 653PC-SP



CAUTION

** This saw has been equipped with a "REMOVABLE" lower wheel
ATTENTION: ELECTRICIAN/SERVICE TECHNICIAN
** READ FIRST BEFORE STARTING POWER CUTTER**

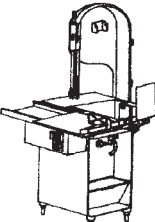

IMPORTANT
This saw has been electrically tested at the factory, but electrical phasing for proper rotation may not match your electrical supply.
WITH LOWER SAW WHEEL REMOVED check rotation of shaft. Rotation must be **counterclockwise** when facing shaft.
Failure to confirm correct rotation could result in wheel dislodging.

Item No. 16716

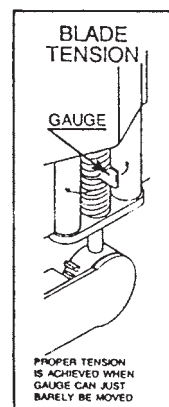

Item No. 710

ALWAYS LOWER GUARD TO HEIGHT OF PRODUCT



D
A
N
G
E
R

E
X
P
O
S
E
D
B
L
A
D
E



Item No. 708

OPERATION



SHARP MOVING BAND TYPE SAW BLADE TO AVOID SERIOUS PERSONAL INJURY

ONLY Properly Trained Personnel Should Use This Equipment.

ALWAYS Keep Hands Clear of Band Type Saw Blade and Other Moving Parts.

NEVER Operate with Saw Guard on Saw Guide Bar in the Raised Position or the Saw Guard Removed from the Saw Guide Bar.

ALWAYS Adjust the Saw Guide Bar with Saw Guard to Within $\frac{1}{2}$ " of Product to be Cut.

ALWAYS Use Safety End Cut Pusher Plate for Smaller Products or The Last Cuts of Product.

DO NOT Wear Gloves While Operating.

DO NOT Tamper With, Bypass, Alter, or Modify this Equipment in Any Way From Its Original Condition.

ALWAYS Turn Off, Unplug from Power Source and Perform Lockout/Tag Out Procedures Before Cleaning, Servicing or When Not in Use.

NEVER Leave Unattended While Operating.

NEVER Operate Without All Warnings Attached and Wall Chart Posted.

A. TO PROCESS PRODUCT

1. Before starting power cutter, adjust saw guide bar with saw guard down to within $\frac{1}{2}$ " (13 mm) of product to be cut.

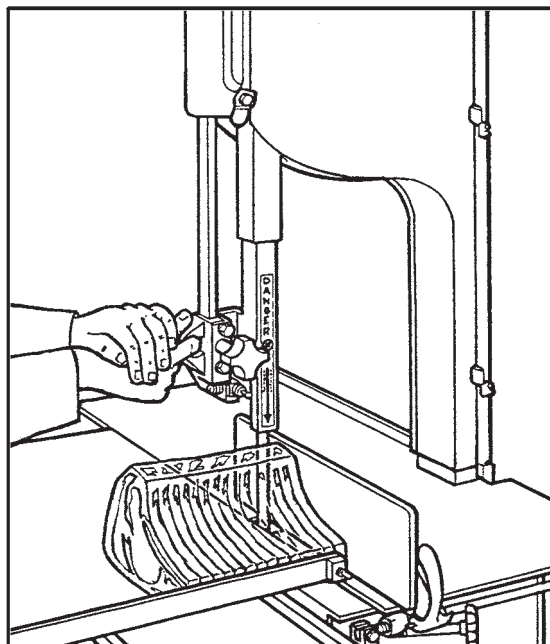



DO NOT WEAR GLOVES WHILE OPERATING

2. Make sure all doors are closed and locked.
3. Adjust meat gauge plate forward to desired thickness of cut.
4. Push start button and watch blade for proper tracking.
5. Standing in front of the power cutter, place product on the meat carriage. Pay attention to position of your hands. Keep hands clear of moving band type saw blade. Leaning lightly against the scalloped front edge of meat carriage, hold the product firmly in right hand with product face flush against meat gauge plate. Move the meat carriage from right to left at a steady rate until fully past the saw blade. Use left hand to remove and stack cut product, **NEVER REACH IN FRONT OF BAND TYPE SAW BLADE**. On the return stroke, pull the product toward you, away from saw blade.



NEVER REACH OR GRAB FOR PRODUCT IN FRONT OF MOVING BAND TYPE SAW BLADE

6. **ALWAYS** use the Safety End Cut Pusher Plate (Part No. 256P) for smaller products or the last cuts of product. The pusher plate is supplied as standard on all BIRO power cutters.

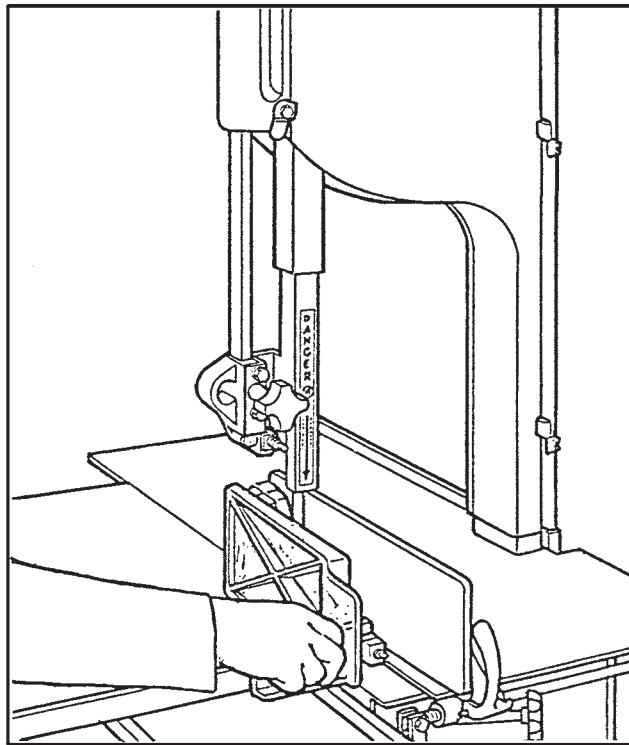

7. When finished cutting, push stop button. Perform lockout/tag out procedure.

CLEANING



SHARP MOVING BAND TYPE SAW BLADE TO AVOID SERIOUS PERSONAL INJURY

ALWAYS Turn Off, Unplug From Power Source and Perform Lockout/Tagout Procedure to This Machine **BEFORE** Cleaning or Servicing.

ONLY Use Recommended Cleaning Equipment, Materials and Procedures.

NEVER Spray Water or Other Liquid Substances Directly at Motor, Power Switch or any Other Electrical Components.

ALWAYS Thoroughly Clean Equipment at Least Daily.

CLEANING THE BIRO POWER CUTTER:

Disconnect electrical power to the machine before cleaning. Parts to be removed have been made accessible and can be removed without tools. Notice in the drawing below that all parts are numbered. Each part should be removed for cleaning in the numbered sequence shown. To ensure cleaner cuts, keep the cleaning system in good condition. Parts on the cleaning system which should be checked weekly, and changed as required are as follows: Wheel Cleaners (Part No. 179), Saw Cleaners (Part No. 131), Saw Guide in Stationary Bar (Part No. 119A), Upper Saw Guide (Part No. 602B), Lower Blade Back-Up Guide (Part No. 605) and Nylon Filler (Part No. 177).

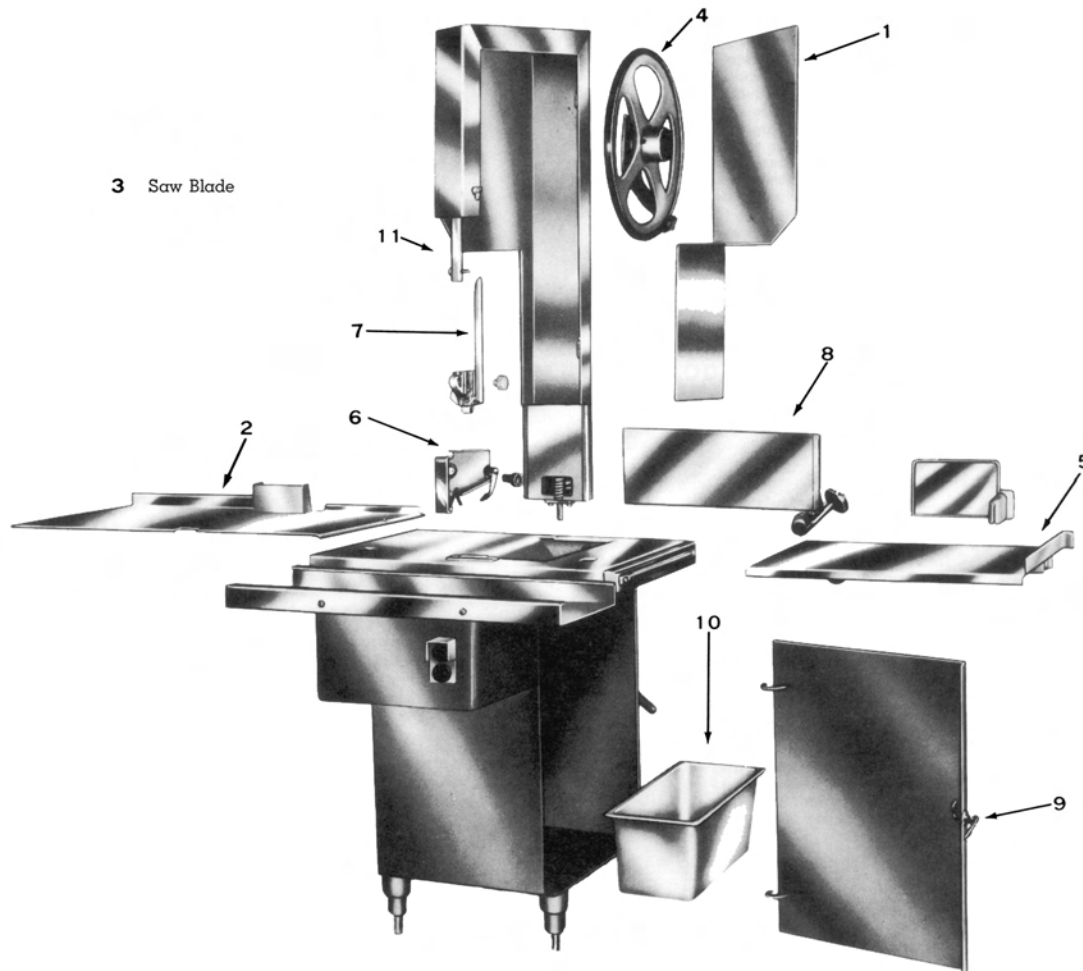

MAINTENANCE



SHARP MOVING BAND TYPE SAW BLADE

TO AVOID SERIOUS PERSONAL INJURY

ALWAYS Turn Off, Unplug From Power Source and Perform Lockout/Tag Out Procedure to This Machine **BEFORE** Cleaning or Servicing.

NEVER Touch This Machine Without Training and Authorization By Your Supervisor.

ALWAYS Keep Hands Clear of Band Type Saw Blade and Other Moving Parts.

NEVER Bypass, Alter, or Modify This Equipment in Any Way From Its Original Condition.

PROMPTLY REPLACE Any Worn or Illegible Warning Labels.

USE ONLY GENUINE BIRO Parts and Accessories Properly Installed.

A. GENERAL

1. Machine should be generally inspected every time it is cleaned (at least daily) to ensure that it is in good condition and has not been damaged or tampered with.
 - a. **SAW WHEELS:** Clean outer diameter grooves daily. Check for cracks, gouges or wear on the flange and grooves.



DO NOT IMMERSE UPPER WHEEL ASSEMBLY IN WATER

- b. **WHEEL CLEANER ASSEMBLIES:** Check condition of fiber cleaner, change every four (4) weeks.
- c. **REMOVABLE FINGER LIFT ASSEMBLY:** Check condition of saw guard, make sure mounting bolts are tight and DANGER EXPOSED BLADE decal is attached and legible. Check condition of upper saw guide (Part No. 602B), replace every six (6) months. Check adjustment of upper saw guide. Should be " between back of blade and saw guide carbide.



NEVER USE THIS MACHINE WITHOUT PROPERLY INSTALLED AND FUNCTIONING SAW GUIDE BAR AND SAW GUARD

- d. **SAW GUIDE BAR:** Check condition of bar for coating peeling and wear, replace as necessary. Check saw guide bar spring for proper tension. The spring should hold the bar in any desired position in its travel. Replace saw guide bar spring (Part No. 193) as necessary using instructions on following page.

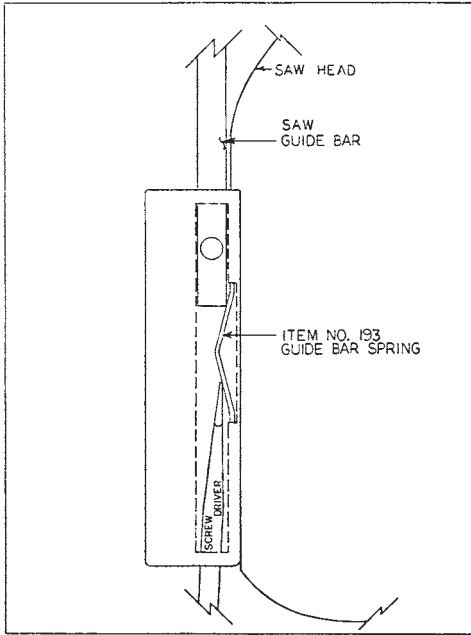

1. Remove the finger lift fastener knob and the fingerlift assembly.
2. Remove the finger lift fastener stud.
3. Push the saw guide bar up and out of the top of the head structure.
4. Remove the saw guide bar spring.
5. Clean and lubricate the babbitt pocket area (the square indented area that seats the saw guide bar spring).
6. Lower the new saw guide bar spring through the top of the babbitt pocket area and guide the spring into position with a standard screwdriver. (NOTE: Drawing)
7. While holding the saw guide bar spring in position, re-enter the saw guide bar from the top compressing the saw guide bar spring slightly until the saw guide bar slides past the spring.
8. Replace the finger lift fastener stud, the fingerlift assembly and the finger lift fastener knob.
9. Test by making several adjustments.

- e. **STATIONARY BAR ASSEMBLY:** Check condition of nylon filler (Part No. 177), change every four (4) weeks. Check condition of saw guide (Part No. 119A), check tracking of blade through guide, back of blade should be centered in hole, replace every six (6) months. Check condition of lower blade back-up guide (Part No. 605). Check adjustment of back-up guide, should have $\frac{1}{32}$ " gap between back of blade and saw guide carbide. Replace every six (6) months.
- f. **SAW CLEANERS:** Check condition of blade cleaners, replace every four (4) weeks.
- g. **RATCHET ASSEMBLY:** Check for smooth operation through full range of travel. Check condition of trigger spring, replace as necessary.
- h. **SLIDE GIBS:** Check that head structure moves freely up and down. Check for side to side and front to rear tolerance, adjust as required. Grease every four (4) weeks.
- i. **MEAT GAUGE ASSEMBLY:** Check free movement of meat gauge plate on gear rack. Gear rack to be kept lubricated at all times with light food grade oil. Check operation of release handle. Check that worm gear engages properly with gear rack. Check tension of release handle spring, replace as necessary.
- j. **MEAT CARRIAGE ASSEMBLY:** Check for free movement through full range of travel. Check for side to side tolerance, adjust as necessary. Check condition and grease bearings, replace as necessary. Check condition of thumb guard, replace as necessary.
- k. **SAFETY ITEMS:** Safety end cut pusher plate is with machine and accessible. All warning labels are present, properly affixed and legible. Model and Serial Number plate properly affixed and legible. Wall poster within operators view from machine. Manual accessible to operator.

B. LUBRICATION

1. **UPPER WHEEL BEARINGS:** Grease every four (4) months. Change grease every twelve (12) months.
2. **LOWER BEARING HOUSING:** Grease every four (4) months. Change grease every twelve (12) months.
3. **SLIDE GIBS:** Grease every four (4) weeks.
4. **MEAT CARRIAGE BEARINGS:** Grease every four (4) weeks.
5. **SAW GUIDE BAR:** Oil daily with food machine oil.
6. **MEAT GAUGE GEAR RACK:** Oil daily with food machine oil.

— NOTE —
USE SHELL CASSIDA
GREASE EPS-2

USE BIRO No. 374 GREASE FOR RE-GREASING SEE INSTRUCTIONS BELOW

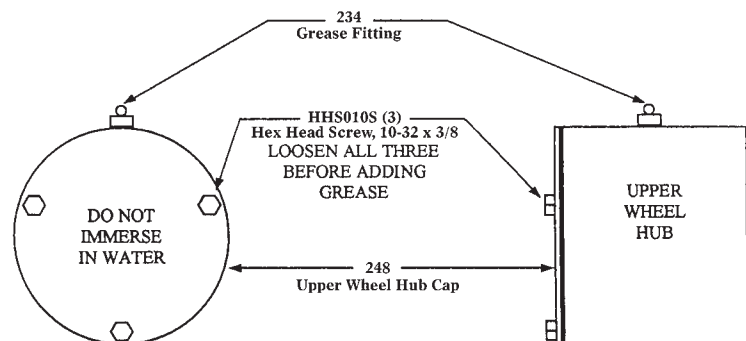

When lubricating the upper wheel bearing it is important that the three hex head screws securing the upper wheel hub cap be loosened slightly before attempting to pump grease into the grease fitting. Loosening the screws allows for an escape of old broken down grease and air from the bearing cavity. Failure to loosen the screws before greasing the upper bearings can cause the upper shaft seal to be dislodged from the upper wheel allowing grease to escape and moisture to get into the cavity. When finished greasing the bearings, retighten the three screws. Take care to also clean off any grease that was forced out of the cavity during greasing.

ITEM NUMBER 671
WALL CHART "BAND SAW SAFETY GUIDELINES"
ATTACH TO WALL IN VICINITY OF MACHINE IN EASY VIEW OF OPERATOR

 **WARNING**

**ONLY PROPERLY TRAINED PERSONNEL
SHOULD USE THIS EQUIPMENT**

**This Saw Contains A Sharp Blade.
To Reduce Risk of Injury:**

1. Before Using, Make Sure:

- Gauge Plate (A) And Other Components Are Secure.
- All Warning Labels And Guards Are In Place.
- The Guide Bar (B) Is Adjusted To ½ Inch Above The Product To Be Cut

2. While Cutting:

- Keep Hands and Fingers Away From Blade.
- Keep Product Securely Against Gauge Plate.
- Use End Cut Pusher (C) When Making Final Cuts. Item No. 256P.

3. Before Cleaning:

- Turn Off Power and Unplug.
- Remove Saw Blade.
- Use Extra Care When Handling The Saw Blade.

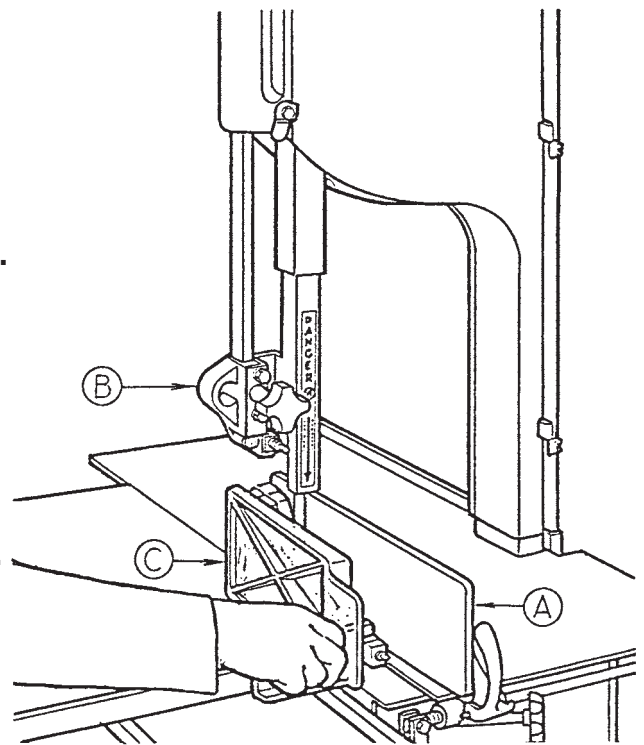

#671

**USE YOUR
MEAT SAW SAFELY!**

SEE PARTS AND SERVICE MANUAL SUPPLIED WITH MACHINE FOR ADDITIONAL SAFETY INFORMATION.

C. MOTOR ADJUSTMENT

Starting with Serial Number 27958 three (3) phase Model 3334's will no longer be equipped with an adjustable motor base plate, Part No. 16015-10 and 16015-11. The motor will be bolted to the bottom of the base structure and V-belt tension adjusted utilizing shims.

This change has evolved as a result of the market demand for higher blade speeds. The revised mounting procedure will insure a more rigid motor installation creating positive belt alignment and minimizing machine vibration.

The base bottom has been redesigned to accept the frame sizes of the current 3 phase motors. Units prior to Serial Number 27958 can be retrofitted by ordering Part No. 16015-12 motor base plate and template (flat), and 36 pieces Part No. 324A motor shims.

ADJUSTMENTS

1. For tightening motor V-belt on rigid base plate, remove appropriate quantity of shims (Part No. 324A) under the motor until the desired total flex of the V-belt is approximately $\frac{1}{2}$ ".

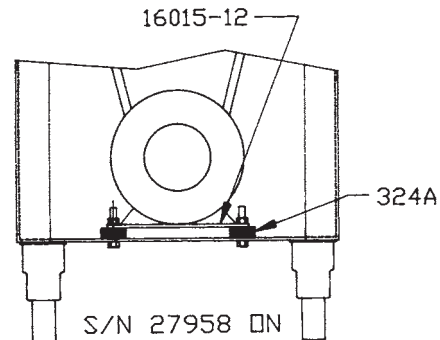

1. For tightening motor V-belt on old style floating adjustable motor mounting plates (Part No. 16015-10 and 16015-11), loosen the upper wing nuts (Part No. 16015-3). Then loosen the bottom wing nuts (Part No. 16015-3) which are located under the mounting plate. This enables the motor mounting plate to drop to the desired belt tension. Re-tighten the upper wing nuts evenly so that the motor stays horizontal. Do not tighten belt to extremes. This will cause undue pressure on and premature failure of the motor bearings.

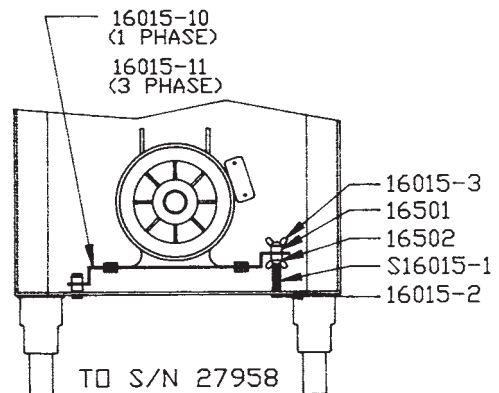

D. SAW GUIDE BAR AND SAW GUARD

The factory recommends that when service is performed on any BIRO SAW the servicing agency be sure that the BIRO SAW is equipped with the most current safety features available.

In September 1969 production of the Model 3334 began and is current. The Model 3334 was first equipped with 19" saw guide bar until March 1973 when the length was extended to 23". In June 1977, the bar was shortened to 22" and is used in current production.

The same saw guard (Part No. 255) on saw guide bar used on the Models 33 and 34 was carried over to the Model 3334 and used in production until June 1975.

Part No. 663 Saw Guard on saw guide bar replaced Part No. 255 in June 1976 starting with Serial No. 12242. At the same time, the Part No. 661 Guard on head Door introduced in 1974 was replaced by Part No. 661-1 Guard on Head Door. Both Part No. 663 and 661-1 are current production today.

The factory recommends that all Model 3334's prior to Serial No. 12242 be updated by installing the current SAW GUIDE BAR ASSEMBLY (Part No. A116-22) and SAW GUARD ON HEAD DOOR (Part No. 661-1).

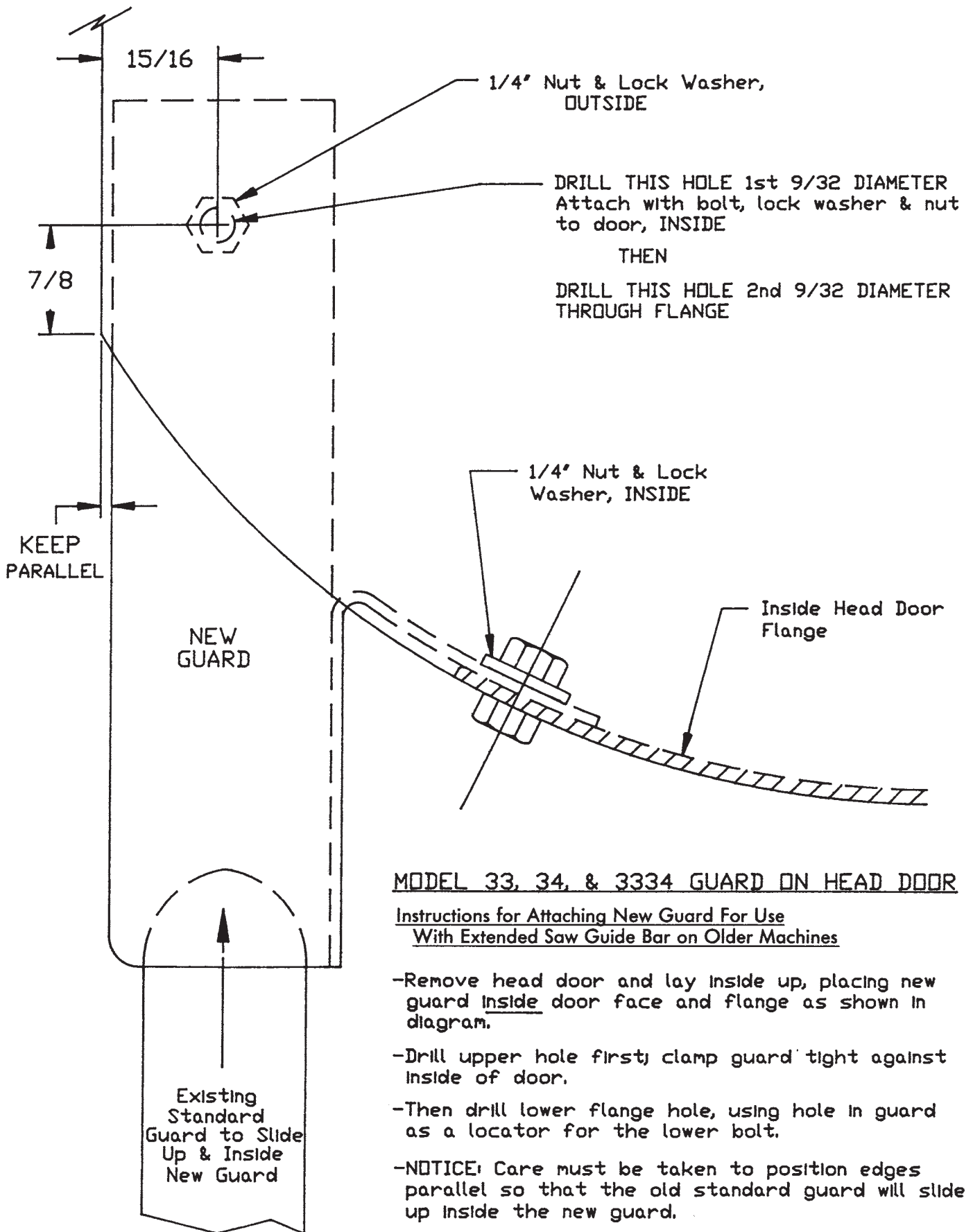

NOTE:

ALWAYS REPORT
MACHINE SERIAL NO.
WHEN ORDERING PARTS.

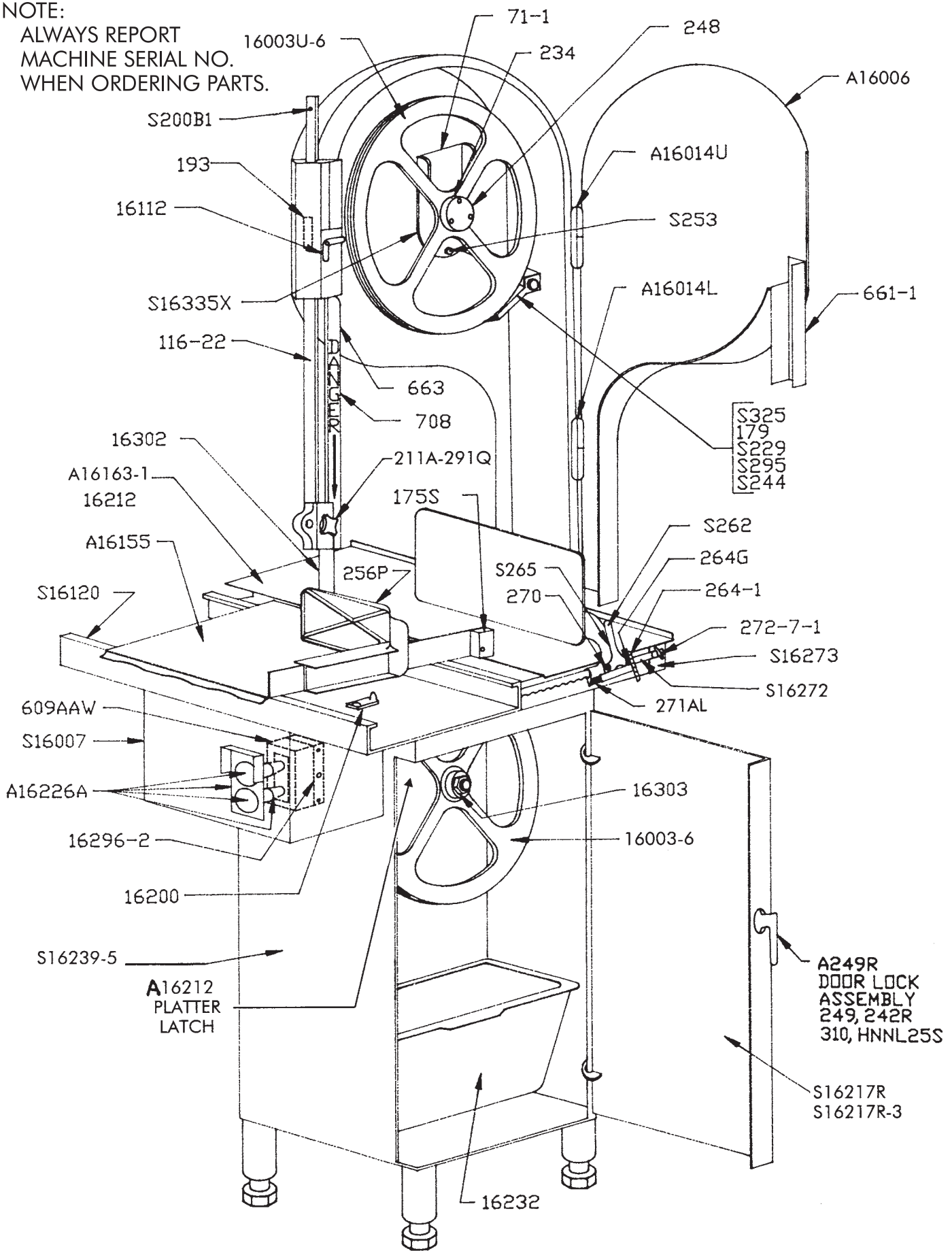

NOTE:
 ALWAYS REPORT
 MACHINE SERIAL NO.
 WHEN ORDERING PARTS.

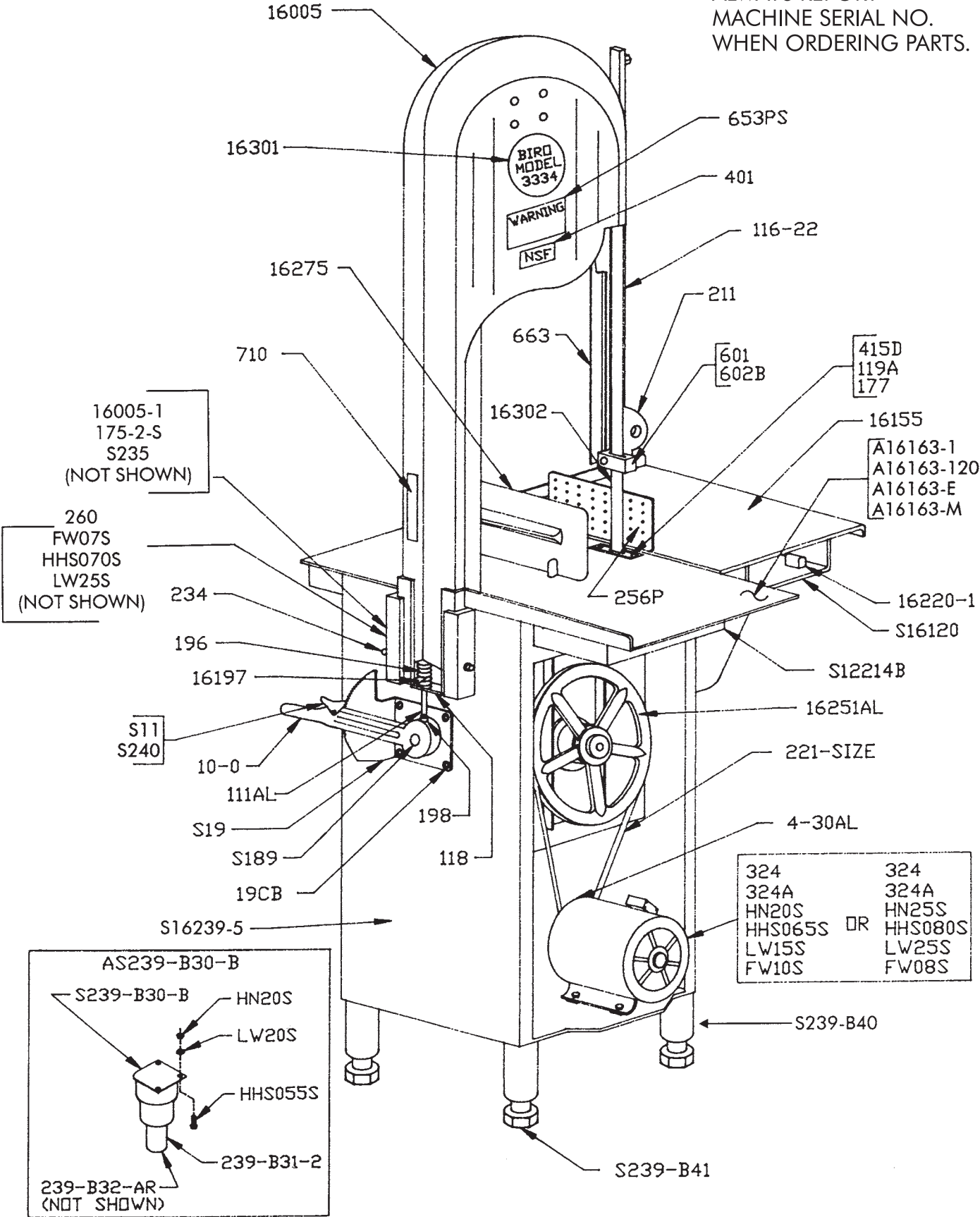

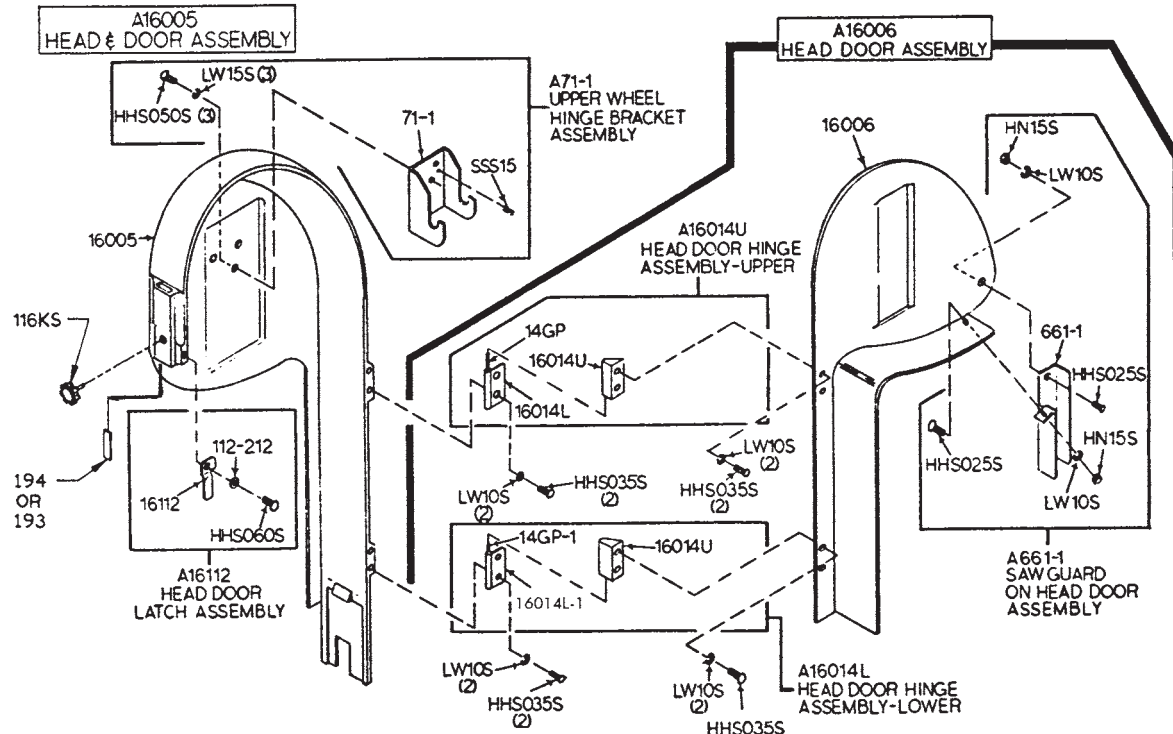

Item No.	Description	Item No.	Description
A16005	Head & door assembly	SSS15	Set screw $\frac{5}{16}$ -18 \times $\frac{5}{16}$ cup point
A16006	Head door assembly	112-212	Waved washer
A16014L	Head door hinge assembly, lower	116KS	Saw guide bar lock knob - aluminum head
16014L-1	Head door hinge - short pin	14GP	Head door hinge pin, $1\frac{1}{2}$ "
A16014U	Head door hinge assembly, upper	14GP-1	Head door hinge pin, $1\frac{1}{4}$ "
A16112	Head door latch assembly	16005	Head, aluminum
A661-1	Saw guard on head door assembly	16006	Head door, aluminum
A71-1	Upper wheel hinge bracket assembly	16014L	Head door hinge, lower half *NSS
HHS025S	Hex head screw, $\frac{1}{4}$ -20 \times $\frac{1}{2}$ SS	16014U	Head door hinge, upper half *NSS
HHS035S	Hex head screw, $\frac{1}{4}$ -20 \times $\frac{5}{8}$ SS	16112	Head door latch
HHS050S	Hex head screw, $\frac{5}{16}$ -18 \times $\frac{5}{8}$ SS	193	Guide bar spring
HHS060S	Hex head screw, $\frac{5}{16}$ -18 \times 1 SS	194	Locking knob pad
HN15S	Hex nut, $\frac{1}{4}$ -20 SS	661-1	Saw guard to head door
LW10S	Lock washer, $\frac{1}{4}$ SS	71-1	Upper wheel hinge bracket
LW15S	Lock washer, $\frac{5}{16}$ SS		

AS16005 HEAD & DOOR ASSEMBLY, SS

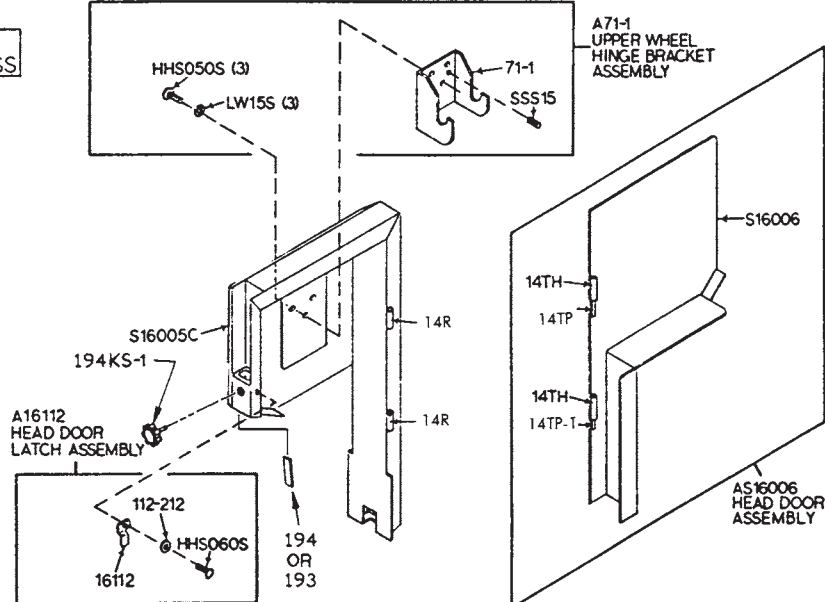

Item No.	Description
A16112	Head door latch assembly
AS16005	Head & door assembly SS
AS16006	Head door assembly SS
A71-1	Upper wheel hinge bracket assembly
HHS050S	Hex head screw, $\frac{5}{16}$ -18 \times $\frac{5}{8}$ SS
HHS060S	Hex head screw, $\frac{5}{16}$ -18 \times 1 SS
LW15S	Lock washer, $\frac{5}{16}$ SS
SSS15	Set screw $\frac{5}{16}$ -18 \times $\frac{5}{16}$ cup point
S16005C	Head SS
S16006	Head door SS
14R	Head door hinge, welded
14TP	Head door hinge pin, $1\frac{1}{2}$ "
14TP-1	Head door hinge pin, $1\frac{1}{4}$ "
112-212	Waved washer
16112	Head door latch
193	Guide bar spring
194	Locking knob pad
194KS-1	Saw guide bar lock knob - stainless head
71-1	Upper wheel hinge bracket

**A19-1
RATCHET ASSEMBLY**

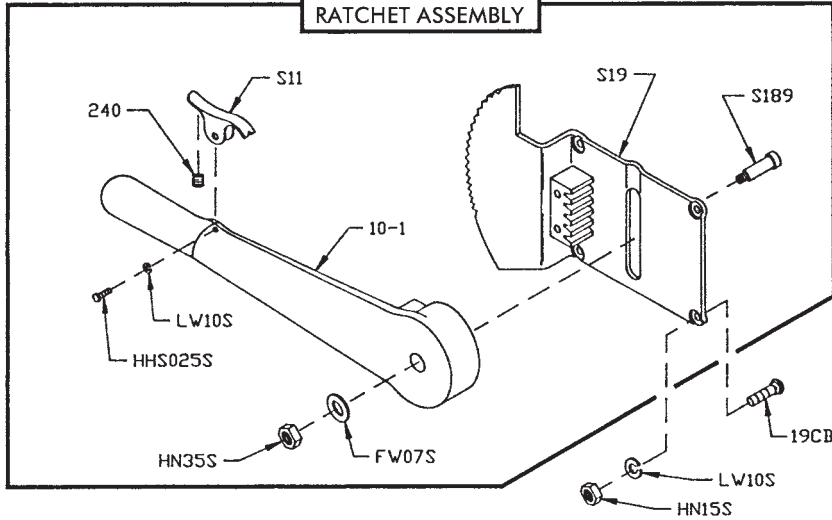

Item No.	Description
A19-1	Ratchet assembly
FW07S	Flat washer, $\frac{3}{8}$ SS
HHS040S	Hex head screw, $\frac{1}{4}$ -20 \times $\frac{3}{4}$ SS
HN15S	Hex nut, $\frac{1}{4}$ -20 SS
HN35S	Hex nut, $\frac{3}{8}$ -16 SS
LW10S	Lock washer, SS
S11	Ratchet trigger SS
S189	Ratchet arm stud SS
S19	Ratchet base SS
10-1	Ratchet arm
19CB	Carriage bolt $\frac{1}{4}$ -20 \times $\frac{3}{4}$ SS
S240	Ratchet trigger spring

**AS16273-S275 MEAT GAUGE
GEAR RACK & BRACKET ASSEMBLY**

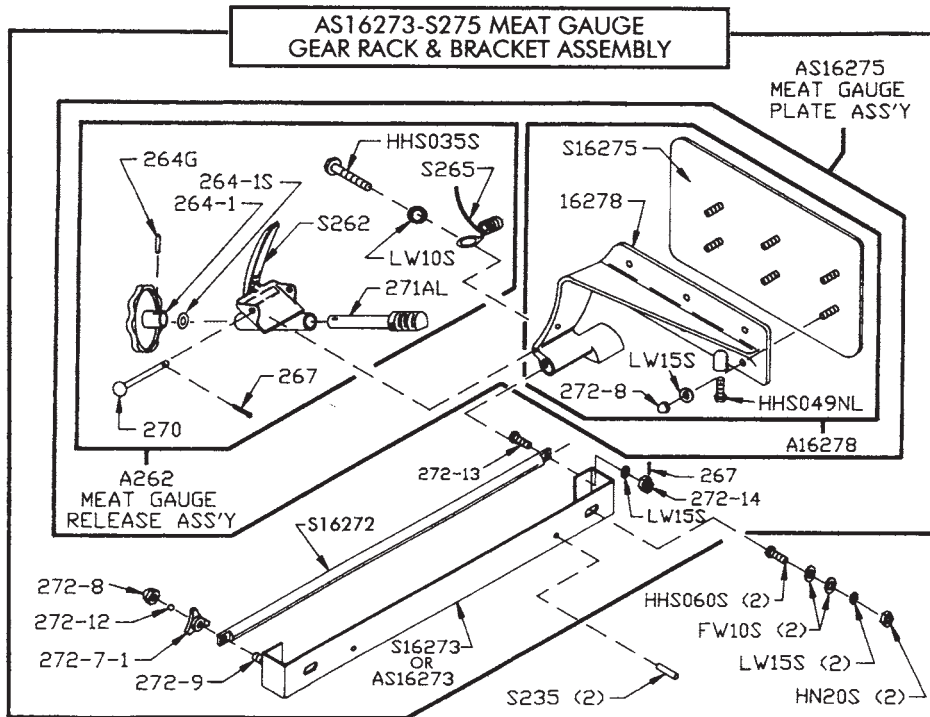

Item No.	Description	Item No.	Description
A16278	Meat gauge plate assembly less release assembly	S235	Taper pin, $4 \times \frac{3}{4}$, SS
A262	Meat gauge release assembly	S262	Meat gauge release handle, SS
AS16273-S275	Meat gauge assembly	16278	Meat gauge arm
AS16275	Meat gauge plate assembly with release assembly	264G	Meat gauge hand wheel groove pin
FW10S	Flat washer, $\frac{5}{16}$, SS	264-1	Meat gauge hand wheel
HHS035S	Hex head screw, $\frac{1}{4}$ -20 \times $\frac{5}{8}$	264-1S	Hand wheel shim
HHS049NL	Hex head screw, $\frac{5}{16}$ -18 \times $\frac{1}{2}$, nylon	S265	Meat gauge release spring
HHS060S	Hex head screw, $\frac{5}{16}$ -18 \times 1, SS	267	Meat gauge release cotter key
HN20S	Hex nut, $\frac{5}{16}$ -18, SS	270	Meat gauge release pin
LW10S	Lock washer, $\frac{1}{4}$, SS	271AL	Meat gauge worm gear, aluminum
LW15S	Lock washer, $\frac{5}{16}$, SS	272-7-1	Lock knob, $\frac{5}{16}$ -18, 3 point
S16272	Meat gauge gear rack, stainless	272-8	Cap nut, $\frac{5}{16}$ -18 SS
S16273	Meat gauge bracket, SS	272-9	Hex bolt, $\frac{5}{16}$ -18 \times 2 SS
S16275	Meat gauge plate, SS	272-12	Brass ball
		272-13	Hex head screw, $\frac{5}{16}$ -18 \times $\frac{1}{4}$, SS
		272-14	Castellated nut, $\frac{5}{16}$ -18, SS

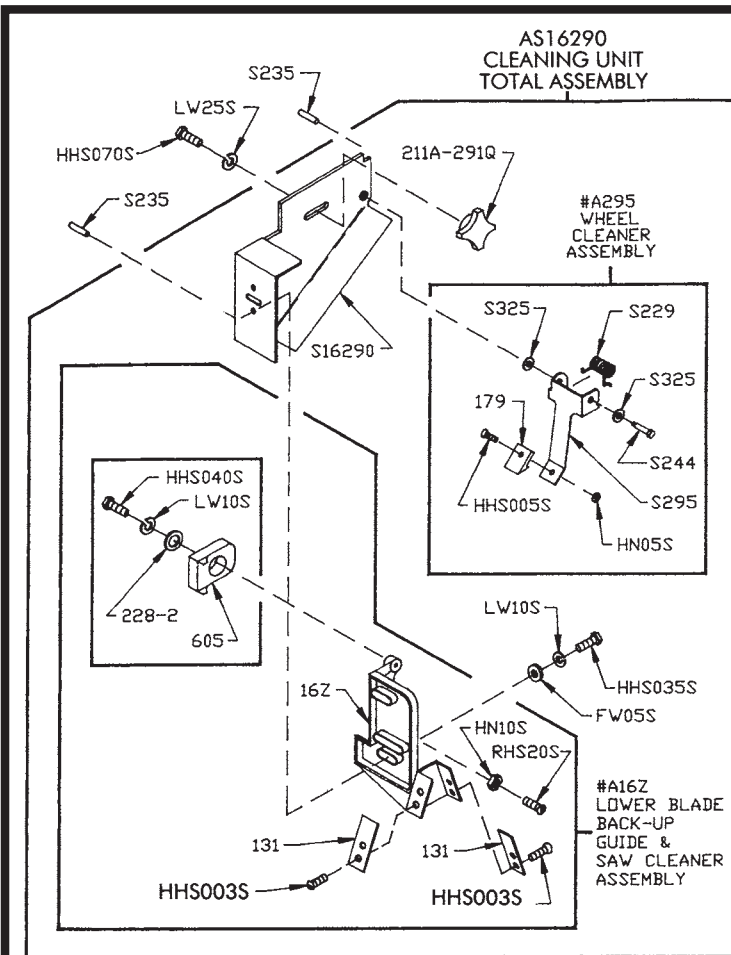

Item No.	Description
A16Z	Guide bracket saw cleaner assembly
A295	Wheel cleaner assembly
AS16290	Cleaning unit total assembly
FW05S	Flat washer, 1/4 SS
HHS003S	Trimmed hex head screw 8-32 x 1/4, SS
HHS005S	Hex head screw, 8-32 x 1/2 SS
HHS035S	Hex head screw, 1/4-20 x 3/8 SS
HHS040S	Hex head screw, 1/4-20 x 3/4 SS
HHS070S	Hex head screw, 3/8-16 x 1 SS
HN05S	Hex nut, 8-32 SS
HN10S	Hex nut, 10-32 SS
LW10S	Lock washer, 1/4 SS
LW25S	Lock washer, 3/8 SS
RHS20S	Round head screw, 10-32 x 1 1/8 SS
S16290	Cleaning unit stamping, SS
S229	Wheel cleaner arm torsion spring SS
S235	Taper pin 4 x 3/4, SS
S244	Wheel cleaner arm stud SS
S295	Wheel cleaner arm SS
S325	Wheel cleaner washer SS
131	Saw cleaner SS
16Z	Lower guide bracket saw cleaner holder
179	Wheel cleaner
211A-291Q	Fastener knob, 4 point
228-2	Lower guide washer
605	Saw guide lower blade back-up

Item No.	Description
A116-22AL	Saw guide bar assembly 22" - aluminum
A116-22SS	Saw guide bar assembly 22" - stainless
A116-22-COS	Saw guide bar assembly - 22" SS special
A211-AL	Finger lift assembly, removable - aluminum
A211-SS	Finger lift assembly, removable - stainless
A211-COS	Finger lift assembly - removable SS special
A602	Saw guide assembly, upper
FW05S	Flat washer, 1/4 SS
HHS015S	Hex head screw, 10-32 x 3/8 SS
HHS020S	Hex head screw, 1/4-20 x 3/8 SS
HHS083S	Hex head screw 3/8-16 x 1 3/4 SS
HN10S	Hex nut, 10-32 SS
LH663	Saw guard for true left head
LW05S	Lock washer, #10 SS
LW10S	Lock washer, 1/4 SS
RHS10S	Round head screw, 10-32 x 3/4 SS
RHS30S	Round head screw, 1/4-20 x 3/8 SS
S200B1	Stop stud on guide bar
116KS	Saw guide bar lock knob - aluminum head
116-22	Saw guide bar, 22"
116-22-COS	Saw guide bar - 22" special
16662	Saw guard for SS head
17211-22	Finger lift, shim, .022
17211-35	Finger lift, shim .035
193	Saw guide bar spring
194	Locking Knob pad
194KS-1	Saw guide bar lock knob - stainless head
211	Finger lift bracket
211A-291Q	Fastener knob, 4 point
601	Upper saw guide bracket
602B	Upper saw guide with carbide
602AFSC	Upper saw guide, narrow, fish
663	Saw guard for aluminum head
708	Decal "DANGER EXPOSED BLADE"

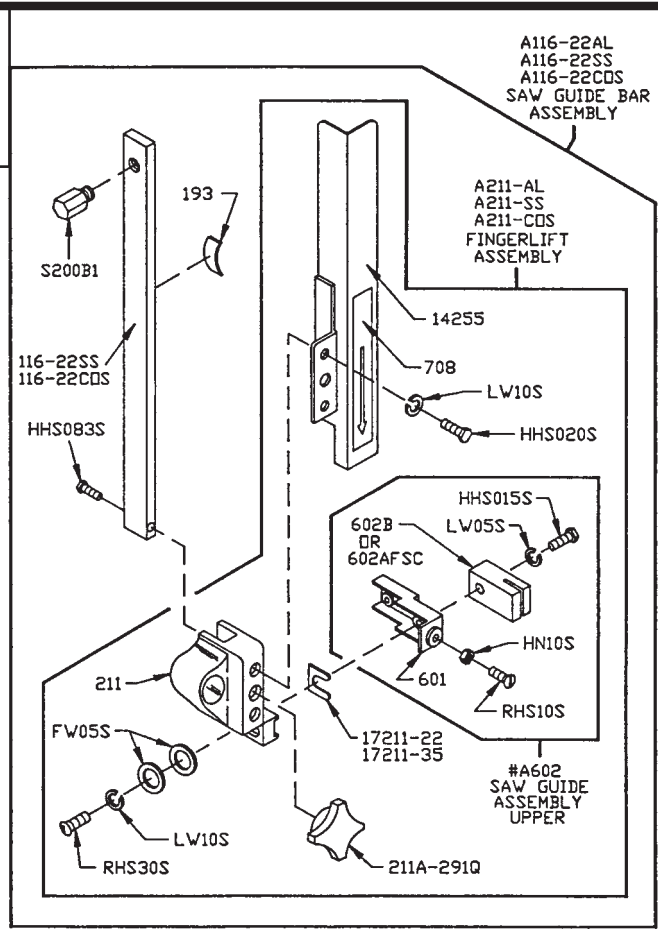

A415D STATIONARY BAR ASSEMBLY

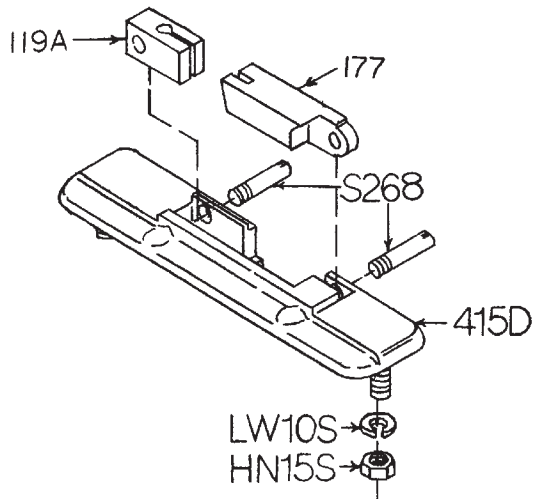

Item No.	Description
A415D	Stationary bar assembly
HN15S	Hex nut $\frac{1}{4}$ -20 SS
LW10S	Lock washer, $\frac{1}{4}$ SS
S268	Stationary bar headless screw
119A	Saw guide in stationary bar
177	Nylon filler
415D	Stationary bar

A16132 REAR STEEL CLEANER ASSEMBLY

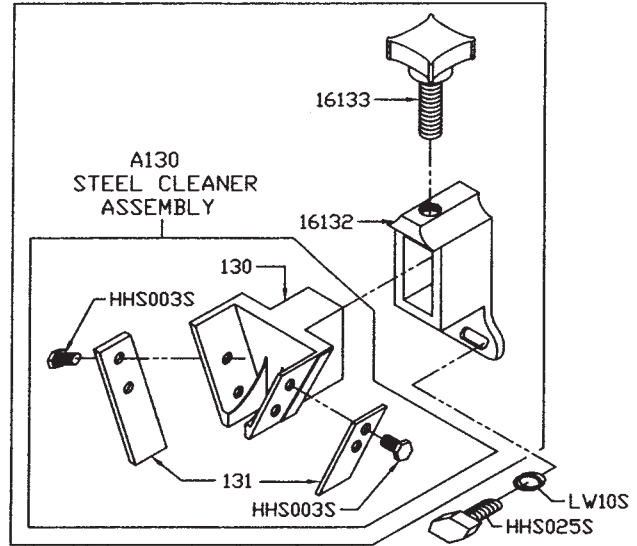

Item No.	Description
A130	Saw cleaner assembly
A16132	Steel cleaner assembly, rear
HHS003S	Trimmed hex head screw 8-32 $\times \frac{1}{4}$ SS
HHS025S	Hex head screw, $\frac{1}{4}$ -20 $\times \frac{1}{2}$ SS
LW10S	Lock washer, $\frac{1}{4}$ SS
130	Saw cleaner bracket rear
131	Saw cleaner SS
16132	Saw cleaner bracket holder, rear
175-2-S	Thumb screw, $\frac{1}{4}$ -20 $\times \frac{1}{2}$
16133	Fastener knob - 4 point

AS415D STATIONARY BAR ASSEMBLY

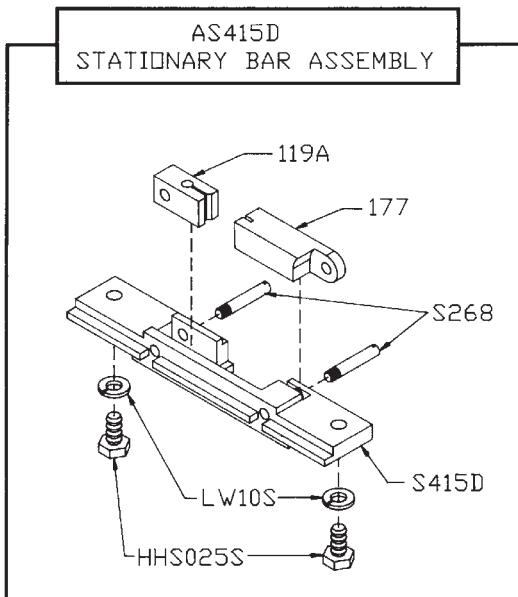

Item No.	Description
AS415D	Stationary bar assembly SS
HHS025S	Hex head screw $\frac{1}{4}$ -20 $\times \frac{1}{2}$ SS
LW10S	Lock washer, $\frac{1}{4}$ SS
S268	Stationary bar headless screw
S415D	Stationary bar SS
119A	Saw guide in stationary bar
177	Nylon filler

A16196 TENSION SPRING ASSEMBLY

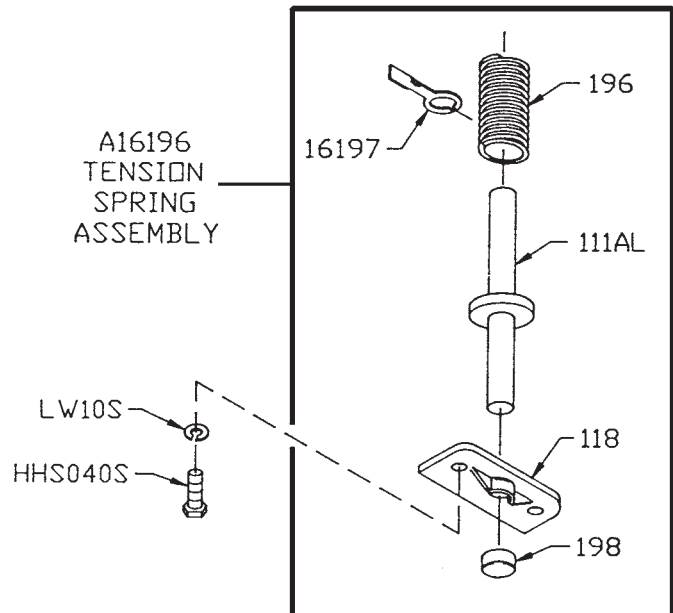

Item No.	Description
A16196	Tension spring assembly
HHS040S	Hex head screw, $\frac{1}{4}$ -20 $\times \frac{3}{4}$ SS
LW10S	Lock washer, $\frac{1}{4}$ SS
111AL	Tension spring pin, ALI
118	Tension spring plate
16197	Tension spring gauge
196	Saw tension spring
198	Cap, for tension pin

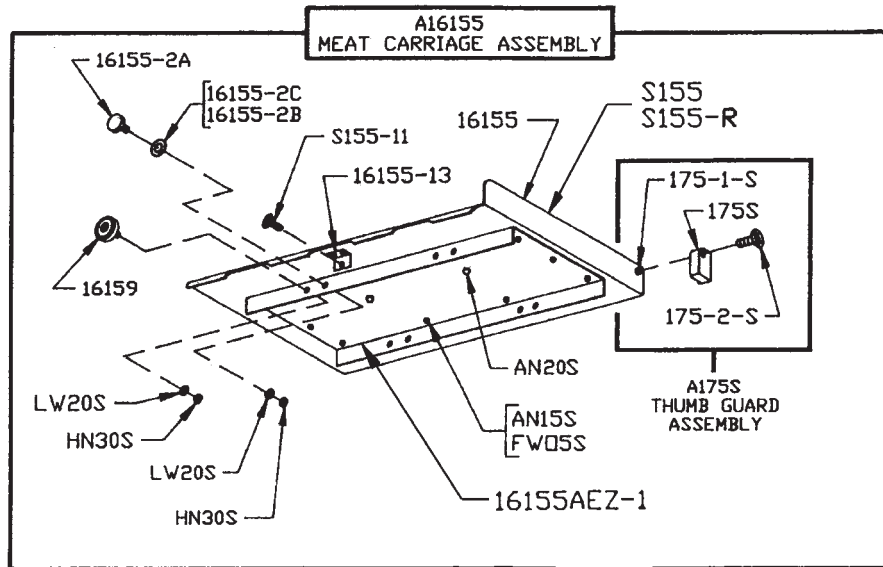

Item No.	Description	Item No.	Description
A16155	Meat carriage assembly complete	16155	Meat carriage top & angle only
A175S	Thumb guard assembly	16155-2A	Meat carriage guide
FW05S	Flat washer, 1/4 SS	16155-2B	Meat carriage guide spacer, 1/4TK
AN15S	Acorn nut, 1/4-20 SS	16155-2C	Meat carriage guide spacer, 1/2TK
AN20S	Acorn nut, 3/8-16 SS	16155-13	Carriage stop angle SS, welded
HN30S	Hex nut, 3/8-16 light jam SS	16155AEZ-1	Meat carriage angle plate only (DNS)
LW20S	Lock washer 3/8 regular SS	16159	Meat carriage bearing SS
S155	Meat carriage top only (NSS)	175S	Thumb guard, nylon
S155-R	Raw meat carriage top only (DNS)	175-1-S	Thumb guard nut SS
S155-11	Meat carriage stop thumb screw	175-2-S	Thumb screw 1/4-20 x 1/2

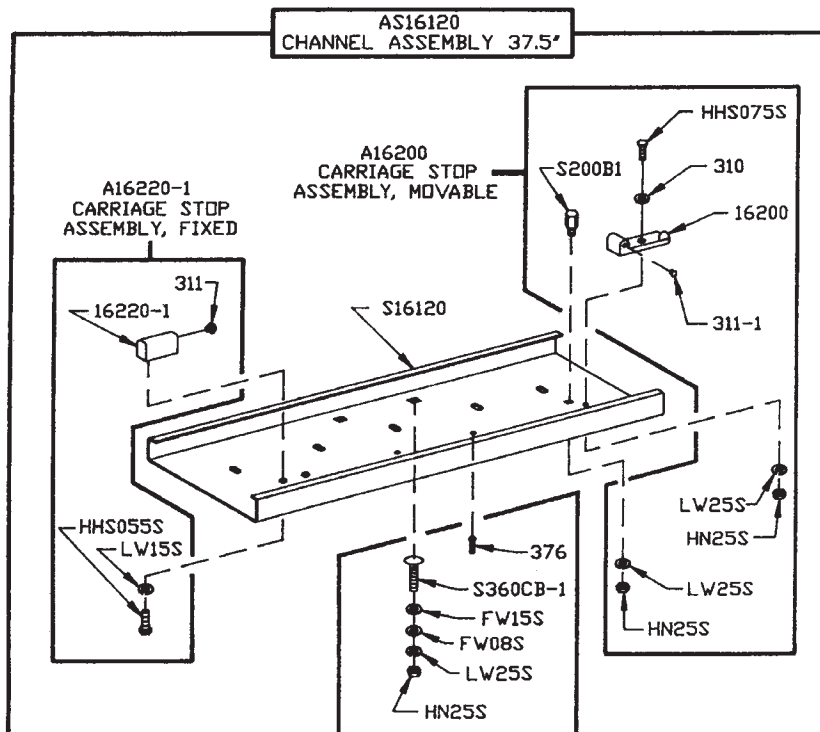

Item No.	Description	Item No.	Description
A16200	Carriage stop assembly, movable	S16120	Channel, 37" SS
A16220-1	Carriage stop assembly, fixed	S200B1	Carriage stop stud SS
AS16120	Channel assembly, 37"	S360CB-1	Carriage bolt, 3/8-16 x 1 1/4 SS
FW08S	Flat washer, 3/8 SS	16200	Carriage stop, movable
FW15S	Flat washer, 1/2 SS	16220-1	Carriage stop, fixed
HHS075S	Hex head screw, 3/8-16 x 1 1/4 SS	310	Waved washer
HN25S	Hex nut, 3/8-16 SS	311	Rubber bumper, fixed stop
LW15S	Lock washer, 3/16 SS	311-1	Rubber bumper, movable stop
LW25S	Lock washer, 3/8 SS	376	Drive screw 10 x 1/2 SS

OPTIONAL 3334 EZ FLOW MEAT CARRIAGE & CHANNEL

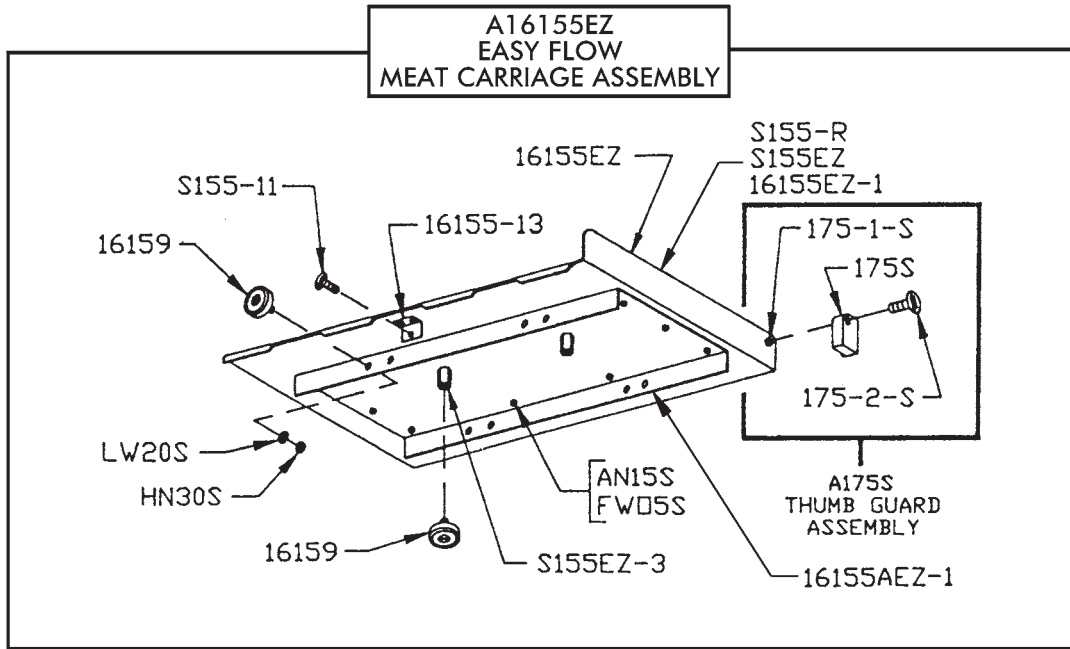

Item No.	Description	Item No.	Description
A16155EZ	Meat carriage assembly complete - EZ Flow	S155EZ-3	Hex stand-off, EZ Flow carriage
A175S	Thumb guard assembly	16155EZ	Meat carriage top & angle only
FW05S	Flat washer, 1/4 SS	16155EZ-1	Meat carriage top only w/weld studs (DNS)
AN15S	Acorn nut, 1/4-20 SS	16155-13	Carriage stop angle SS
HN30S	Hex nut, 3/8-16 light jam SS	16155AEZ-1	Meat carriage angle plate
LW20S	Lock washer 3/8 regular SS	16159	Meat carriage bearing SS
S155-11	Meat carriage stop thumb screw	175S	Thumb guard, nylon
S155-R	Raw meat carriage top only (DNS)	175-1-S	Thumb guard nut SS
S155EZ	Meat carriage top only (NSS)	175-2-S	Thumb screw 1/4-20 x 1/2, SS

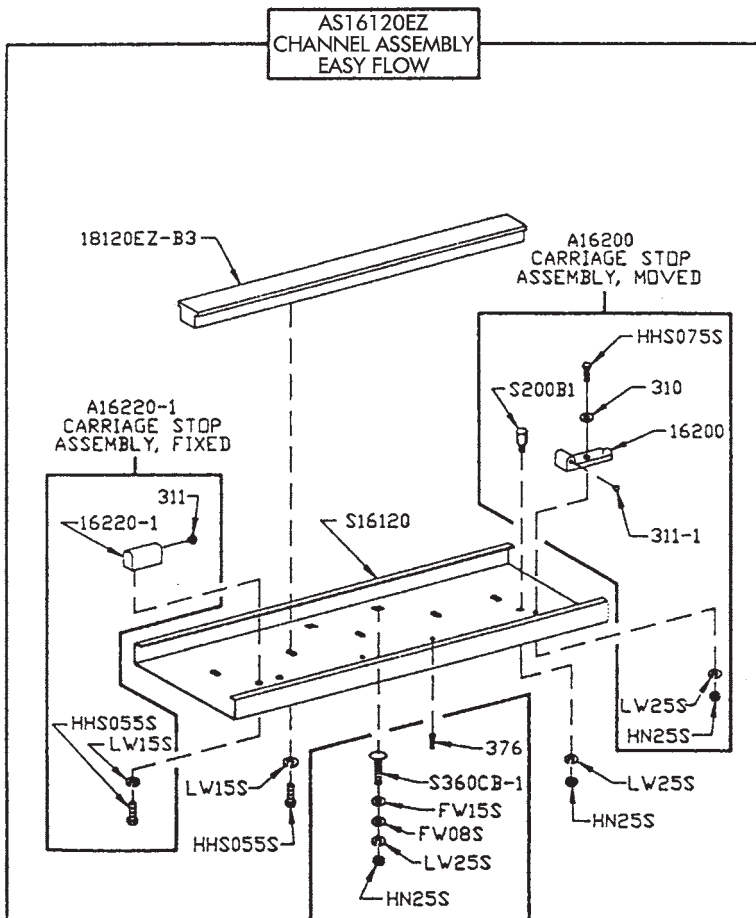

Item No.	Description
A16200	Carriage stop assembly, movable
A16220-1	Carriage stop assembly, fixed
AS16120EZ	Channel assembly, 37" - EZ Flow
FW08S	Flat washer, 3/8 SS
FW15S	Flat washer, 1/2 SS
HHS055S	Hex head screw, 5/16-18 x 3/4 SS
HHS075S	Hex head screw, 3/8-16 x 1 1/4 SS
HN25S	Hex nut, 3/8-16 SS
LW15S	Lock washer, 5/16 SS
LW25S	Lock washer, 3/8 SS
S16120	Channel, 37" SS
S200B1	Stop stud SS, guide bar & carriage stop
S360CB-1	Carriage bolt, 3/8-16 x 1 1/4 SS
16200	Carriage stop, movable
16220-1	Carriage stop, fixed
18120EZ-B3	Guide bar - EZ Flow
310	Waved washer
311	Rubber bumper, fixed stop
311-1	Rubber bumper, movable stop
376	Drive screw 10 x 1/2 SS

MODEL 3334, SERIES 4003 EZ FLOW CARRIAGE & CHANNEL

A181155EZ MEAT CARRIAGE ASSEMBLY EZ FLOW

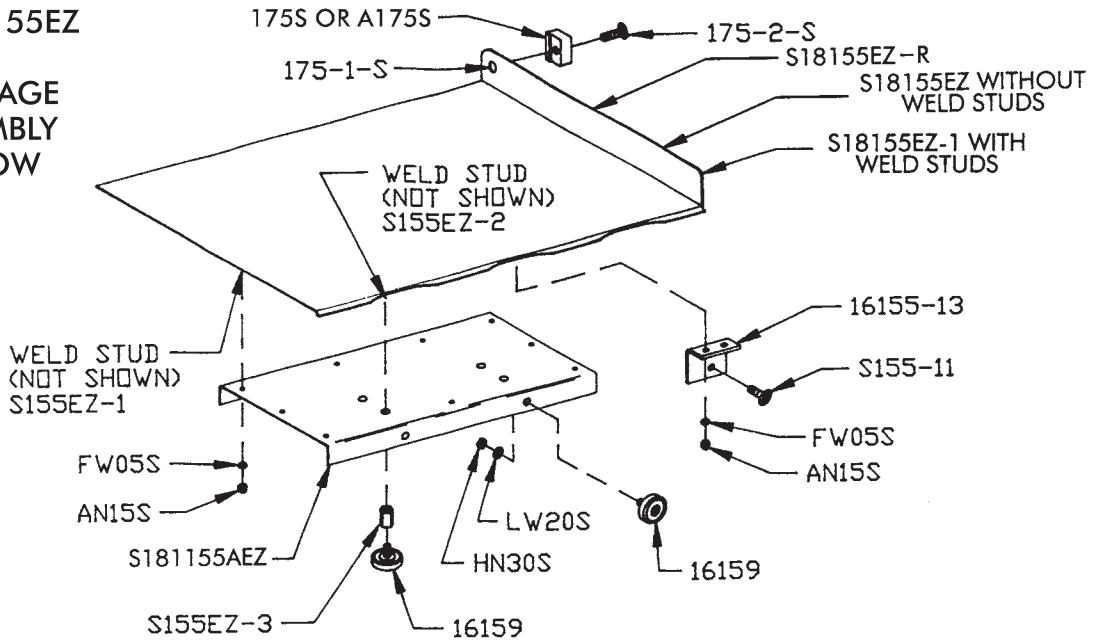

Item No.	Description
A175S	Thumb guard assembly
A181155EZ	Meat carriage assembly, EZ Flow
AN15S	Acorn nut, 1/4-20
FW05S	Flat washer, 1/4
HN30S	Hex nut, 3/8-16 light jam
LW20S	Lock washer, light
S155-11	Carriage stop thumb screw
S155EZ-1	Weld stud - NSS
S155EZ-2	Weld stud - NSS

Item No.	Description
S181155AEZ	Carriage bearing angle plate
S18155EZ-1	Carriage top w/weld studs
S18155EZ	Carriage top without weld studs
S18155EZ-R	Raw meat carriage top only (DNS)
S155EZ-3	Hex stand-off
16155-13	Carriage top angle SS
16159	Carriage bearing
175S	Thumb guard
175-1-S	Thumb guard nut
175-2-S	Thumb screw 1/4-20 x 1/2

AS1120EZ CHANNEL ASSEMBLY EZ FLOW

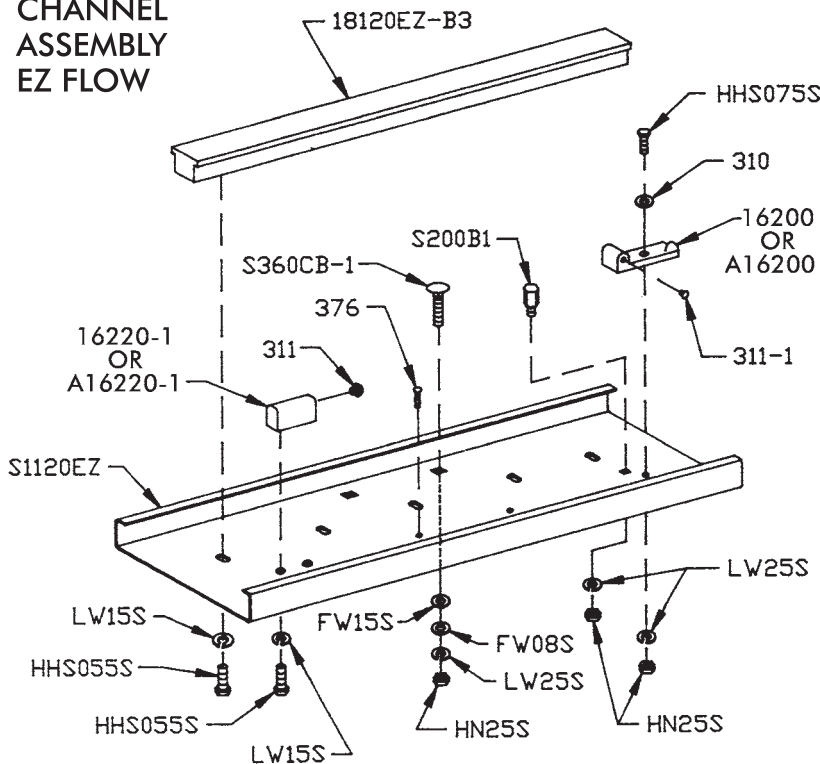

Item No.	Description
A16200	Carriage stop assembly, movable
A16220-1	Carriage stop assembly, fixed
AS1120EZ	Channel assembly, EZ Flow
FW08S	Flat washer, 3/8
FW15S	Flat washer, 1/2
HHS055S	Hex head screw, 5/16-18 x 3/4
HHS075S	Hex head screw, 3/8-16 x 1/4
HN25S	Hex nut, 3/8-16
LW15S	Lock washer, 5/16
LW25S	Lock washer, 3/8
S1120EZ	Channel, EZ Flow
16200	Carriage stop, movable
16220-1	Carriage stop, fixed
18120EZ-B3	Carriage guide bar, EZ Flow
310	Waved washer
311	Rubber bumper, fixed stop
311-1	Rubber bumper, movable stop
376	Drive screw 10 x 1/2 SS
S200B1	Stop stud, SS
S360CB-1	Carriage bolt, 3/8-16 x 1/4

NOT SHOWN
S1007 Channel bracket, SS

— NOTES —

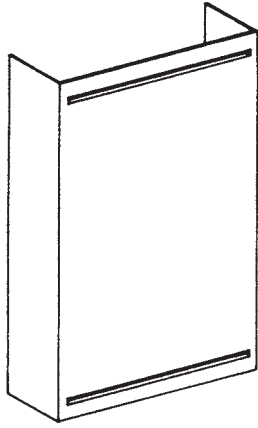

S16217L
Base Door Left, SS

USE WITH

Motor Mfg.	Model No.	Specifications
Doerr	XR72927	1½HP, 220/440-50/60-3 open
Doerr	R72929	2HP, 220/440-50/60-3 open
U.S. Motor	G54313	2HP, 220/440-50/60-3 open
Doerr	73020	2HP, 550-60-3 open
U.S. Motor	G57016	2HP, 550-60-3 open

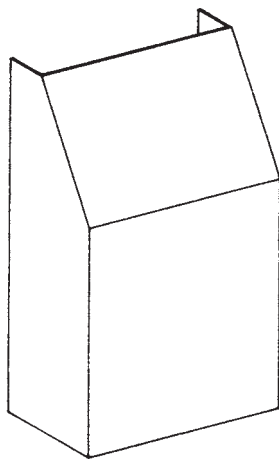

S16217LTP
Base Door, Left Tapered Panel, SS

USE WITH

Motor Mfg.	Model No.	Specifications
Doerr	73032	1½HP, 115/230-50-1 open
U.S. Motor	G57347	1½HP, 115/230-50-1 open
Doerr	72933	1½HP, 115/230-60-1 open
Baldor	L3605	2HP, 115/230-60-1 TE
Baldor	L3605-50	2HP, 115/230-50-1 TE
Baldor	L1322T	2HP, 115/230-60-1 open
Doerr	67385	2HP, 208/220/440-50/60-3 TE
Baldor	M3558T-5	2HP, 550-60-3 TE
Baldor	M3558T-50	2HP, 220/380/415-50-3 TE
Baldor	M3558T-8	2HP, 200-60-3 TE
Doerr	72540	3HP, 220/440-50/60-3 TE
Doerr	75425	3HP, 220/440-50/60-3 TE
U.S. Motor	G57011	3HP, 220/440-50/60-3 TE
Baldor	M3611	3HP, 220/440-50/60-3 TE
Baldor	M3611T-50	3HP, 220/380/440-50-3 TE
Baldor	M3611T-8	3HP, 200-60-3 TE
Doerr	73031	5HP, 220/440-50/60-3 TE
Doerr	A907	5HP, 220/440-50/60-3 TE

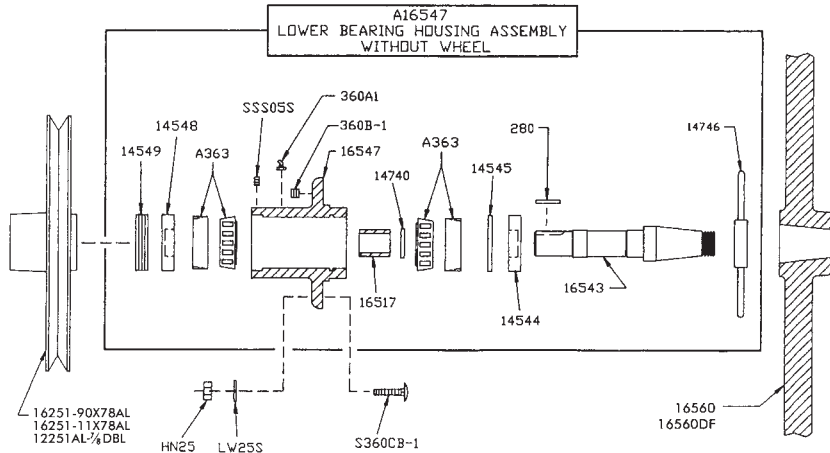

Item No.	Description
A16547	Lower bearing housing assembly without wheel
A363	Lower bearing cup/cone assembly
HN25	Hex nut ⅝-16, carbon-plated
LW25S	Lock washer, ⅝ heavy
S360CB-1	Carriage bolt, ⅝-16 x 1¼
SSS05S	Set screw, 10-24 x ⅜
12251AL-7/8DBL	Pulley, 9 x ⅞ double V
14544	Grease seal
14545	Retaining ring, internal
14548	Grease seal
14549	Bearing adj. cap

Item No.	Description
14740	Retaining ring – external
14746	T-handle lock, removable lower wheel
16251-11 x 78AL	Pulley, 11.4 x ⅞ AL
16251-90X78AL	Pulley, 9 x ⅞ al.
16517	Inner race spacer
16543	Lower shaft, remov. wheel
16547	Lower bearing housing
16560	Lower wheel, 16", 6 spoke removable
16560DF	Lower wheel, 16", 6 spoke removable – double flange
280	Lower shaft motor key
360A1	Grease fitting – angled
360B-1	Set screw, ½-13 SS

A609AAW-16 SWITCH ASSEMBLY

Item No.	Description
A16226A	Green/red switch button assembly w/springs
A609AAW-16	Switch assembly, 1 & 3 ph less heater coils
H462	Guard for switch toggle
H462A	Guard assembly for switch toggle
H462-1	Trim ferrule, SS
HHS010S	Hex head screw, 10-32 x 3/8 SS
HHS070S	Hex head screw, 3/8-16 x 1 SS
HN10S	Hex nut, 10-32 SS
HN20S	Hex nut 5/16-18 SS heavy
LW15S	Lock washer 5/16 SS regular
LW25S	Lock washer, 3/8 SS
16296-2	Switch bracket SS
150	Conduit, 1/2"
224	Conduit connector, 180°
226-28	Washer SS, 1 1/2 x 27/32
241BL	Wire, black, 12GA., CSA & UL
241WH	Wire, white, 12GA., CSA & UL
259	Anti-short busing 1/2"
340	Star lock washer
609AAW	Manual switch, size 0, 1 & 3 ph

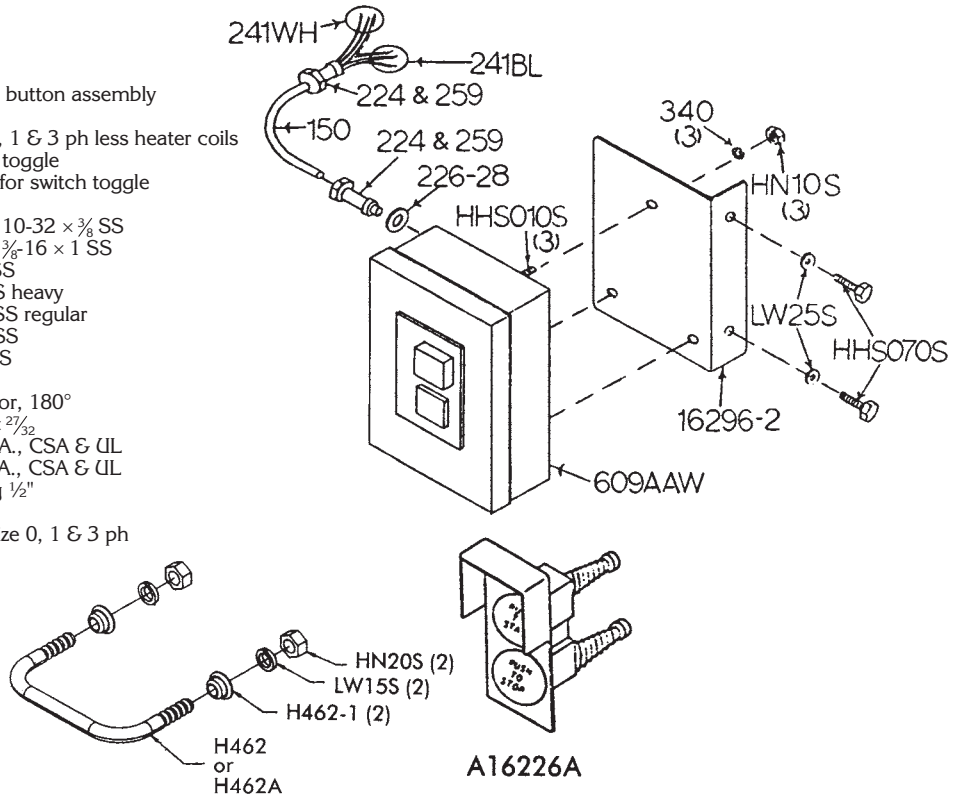

609AAW 3 - PHASE

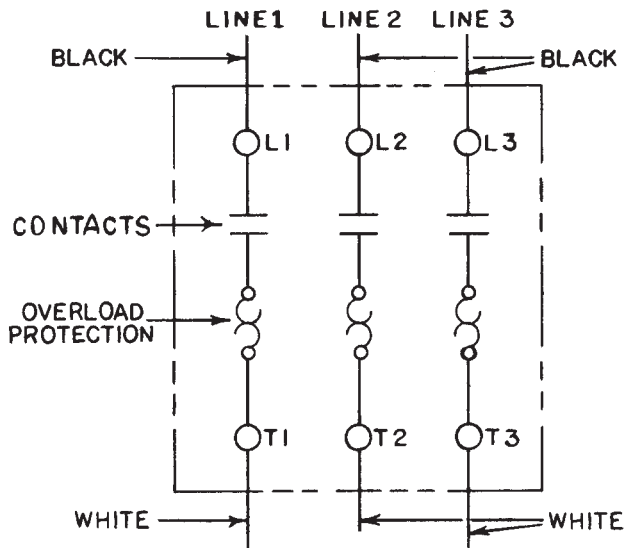

- Wire Diagram for Baldor Motor - - Spec. No. 35M388S508 - 230V/1 Phase/50Hz Used with 609 AAW Starter, A-B

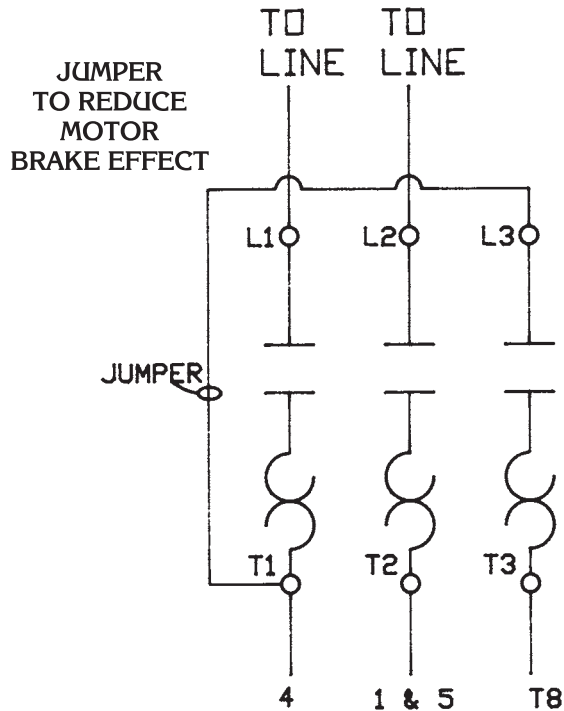

**MOTOR LEADS
SWITCH 5 & 8 FOR CORRECT ROTATION**

WATERTIGHT MAGNETIC SWITCH ASSEMBLIES (AEG) INCLUDES MOUNTING BRACKET AND WIRES

Item No.	Description	Item No.	Description
A22616AE-506	BAEG/PC-PB/C6, 1½HP, 208/220/230-50/60-3	A22616AE-526	BAEG/PC-PB/C17, 2HP, 230-60-1
A22616AE-514	BAEG/PC-PB/C8, 2HP, 208/220/230-50/60-3	A22616AE-530	BAEG/PC-PB/F2.8, 2HP, 550-60-3
A22616AE-516	BAEG/PC-PB/E4, 1½HP, 440/460-3	A22616AE-534	BAEG/PC-PB/E6, 3HP, 440/460-60-3
A22616AE-518	BAEG/PC-PB/D6, 1½HP, 380/415-50-3; 2HP, 380/415-50-3	A22616AE-536	BAEG/PC-PB/D8, 3HP, 380/415-50-3
A22616AE-520	BAEG/PC-PB/A23, 1½HP, 104/115-50/60-1	A22616AE-538	BAEG/PC-PB/F4, 3HP, 550-60-3
A22616AE-522	BAEG/PC-PB/C12, 1½HP & 3HP, 208/220/230-50/60-1	A22616AE-540	BAEG/PC-PB/C23, 5HP, 208/220/230-50/60-3
A22616AE-524	BAEG/PC-PB/A32, 2HP, 115-60-1	A22616AE-543	BAEG/PC-PB/E8, 5HP, 440-60-3
		A22616AE-546	BAEG/PC-PB/D12, 5HP, 380/415-50-3
		A22616AE-548	BAEG/PC-PB/F8, 5HP, 550-60-3

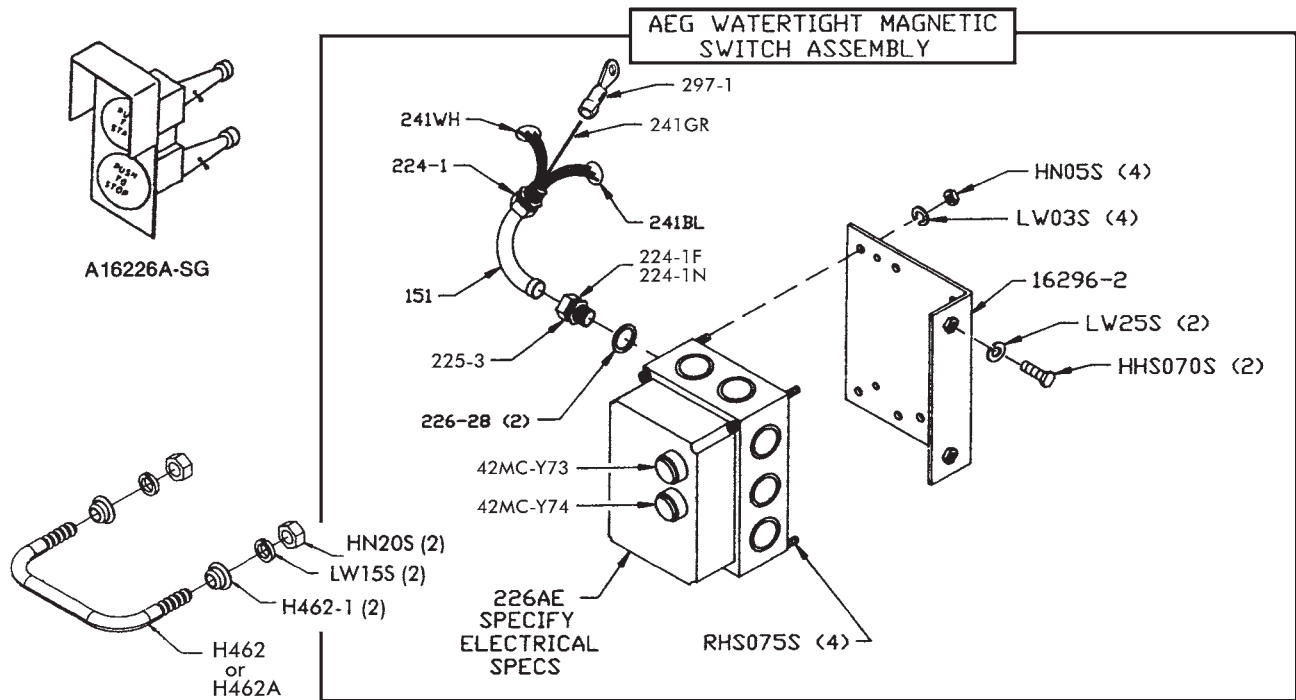

Item No.	Description	Item No.	Description
A16226A-SG	Green/red switch button assembly	226AE-D0	Contact, SP17.10-D0, 380/415V
H462	Guard for switch toggle	226AE-E0	Contact, SP17.10-E0, 440V
H462A	Guard assembly for switch toggle	226AE-F0	Contact, SP17.10-F0, 550V
H462-1	Trim ferrule S.S.	226AE-506	BAEG/PC-PB/C6
HHS070S	Hex head screw, ⅜-16 × 1 SS	226AE-514	BAEG/PC-PB/C8
HN05S	Hex nut, 8-32 SS	226AE-516	BAEG/PC-PB/E4
HN20S	Hex nut ⅝-18 S.S.	226AE-518	BAEG/PC-PB/D6
LW03S	Lock washer, #8 SS	226AE-520	BAEG/PC-PB/A23
LW15S	Lock washer ⅜ S.S.	226AE-522	BAEG/PC-PB/C12
LW25S	Lock washer, ⅜ heavy SS	226AE-524	BAEG/PC-PB/A32
RHS075S	Round head screw, 8-32 × ⅜ SS	226AE-526	BAEG/PC-PB/C17
16296-2	Switch bracket SS	226AE-530	BAEG/PC-PB/F.2.8
151	Watertight conduit	226AE-534	BAEG/PC-PB/E6
224-1	Conduit connector, WT, 180°	226AE-536	BAEG/PC-PB/D8
224-1F	Conduit ferrule for watertight connector	226AE-538	BAEG/PC-PB/F4
224-1N	Conduit nut for watertight connector	226AE-540	BAEG/PC-PB/C23
226AE-ENCL-PB	Enclosure with button holes	226AE-543	BAEG/PC-PB/E8
226AE-0L02H	Overload, B17S-H (1.8-2.8)	226AE-546	BAEG/PC-PB/D12
226AE-0L04I	Overload, B17S-I (2.8-4)	226AE-548	BAEG/PC-PB/F8
226AE-0L06K	Overload, B17S-K (4.6)	226-28	Washer, 1½ × ⅜ SS
226AE-0L08L	Overload, B17S-L (5.6-8)	241BL	Wire, black, 12 GA., CSA & UL
226AE-0L12M	Overload, B17S-M (8-12)	241GR	Wire, green, 12 GA., CSA & UL
226AE-0L17N	Overload, B17S-N (11-17)	241RD	Wire, red, 12 GA., CSA & UL
226AE-0L23O	Overload, B17S-O (15-23)	241WH	Wire, white, 12 GA., CSA & UL
226AE-0L32P	Overload, B17S-P (22-32)	297-1	Wire terminal eyelet for 12 Ga. wire
226AE-A0	Contact, SP17.10-A0, 110V	42MC-Y73	Green start push button assembly
226AE-C0	Contact, SP17.10-C0, 208/220/230V	42MC-Y74	Red stop push button assembly

- 115 Volt with 7 Motor Leads -

**Model 3334 Schematic Using 3-Pole Stromberg or AEG W.T. Switch
for 115 Volts, Single Phase, 60 Cycle Baldor Motor with 7 Motor Leads
TO ELIMINATE BREAKING EFFECT OF MOTOR AFTER STOP IS ENGAGED**

*To Reverse Rotation
Interchange Leads 5 & 8

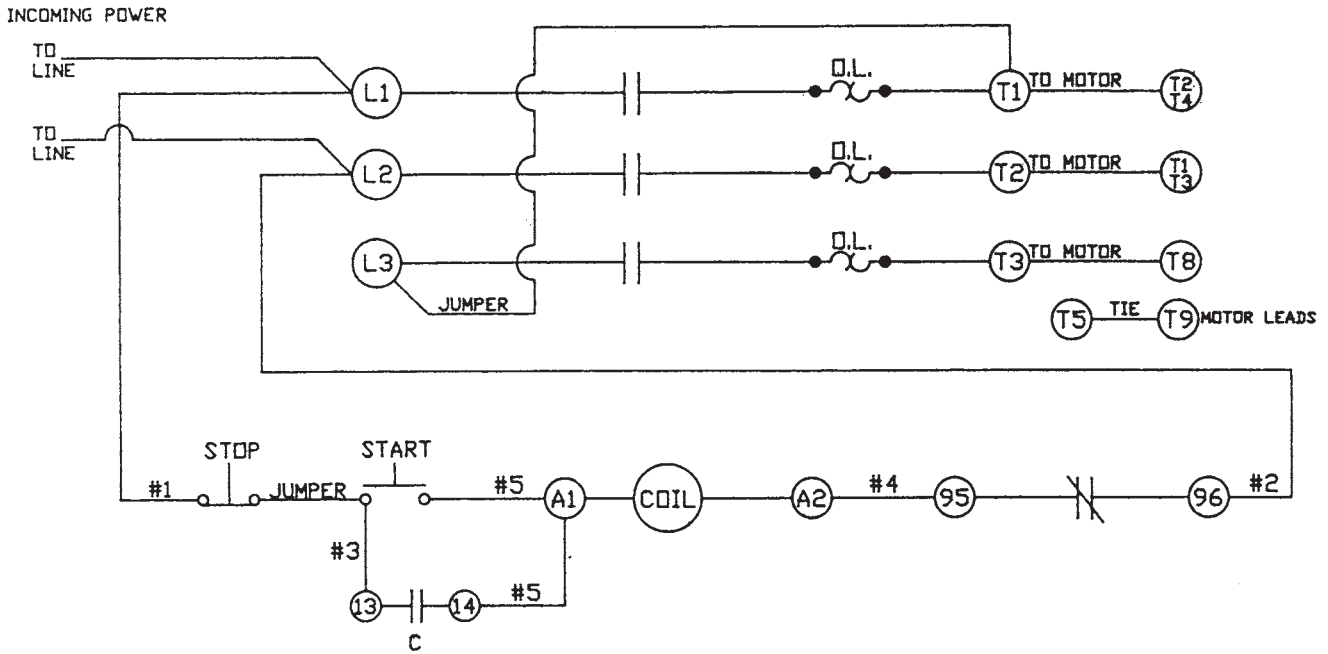

- 115 Volt with 6 Motor Leads -

**Model 3334 Schematic Using 3-Pole Stromberg or AEG W.T. Switch
for 115 Volts, Single Phase, 60 Cycle Baldor Motor with 6 Motor Leads
TO ELIMINATE BREAKING EFFECT OF MOTOR AFTER STOP IS ENGAGED**

*To Reverse Rotation
Interchange Leads 5 & 8

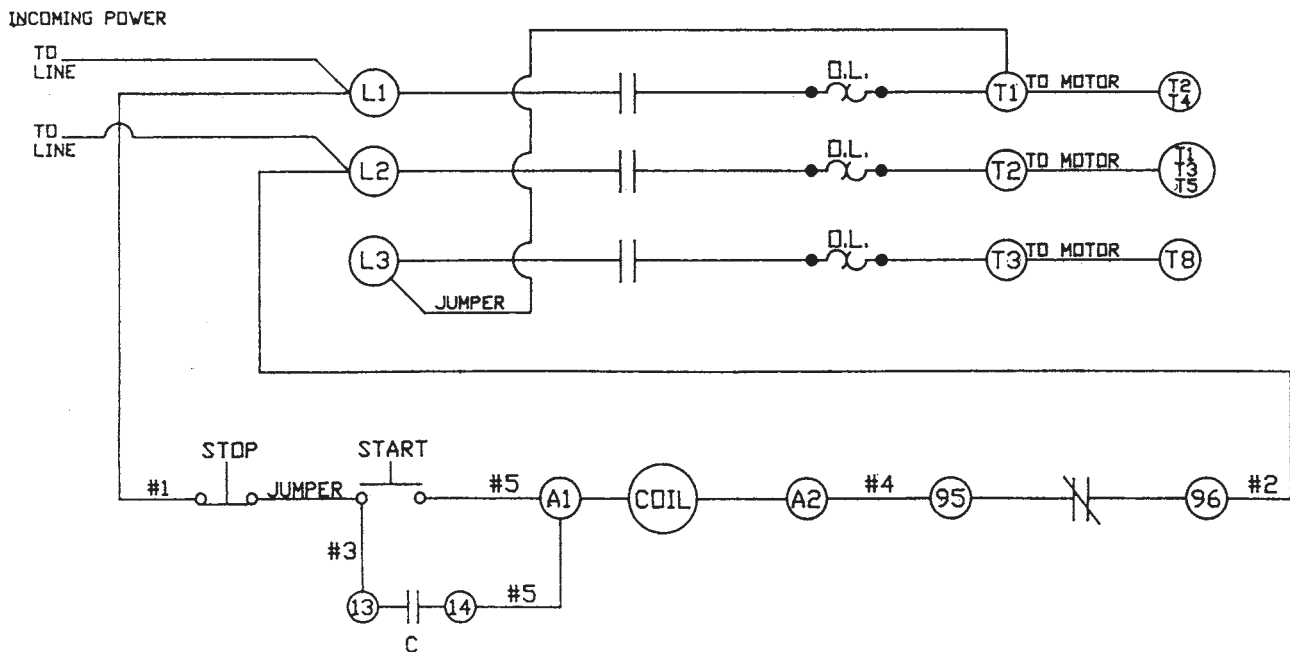

- 230 Volt with 7 Motor Leads -

**Model 3334 Schematic Using 3-Pole Stromberg or AEG W.T. Switch
for 230 Volts, Single Phase, 60 Cycle Baldor Motor with 7 Motor Leads
TO ELIMINATE BREAKING EFFECT OF MOTOR AFTER STOP IS ENGAGED**

*To Reverse Rotation
Interchange Leads 5 & 8

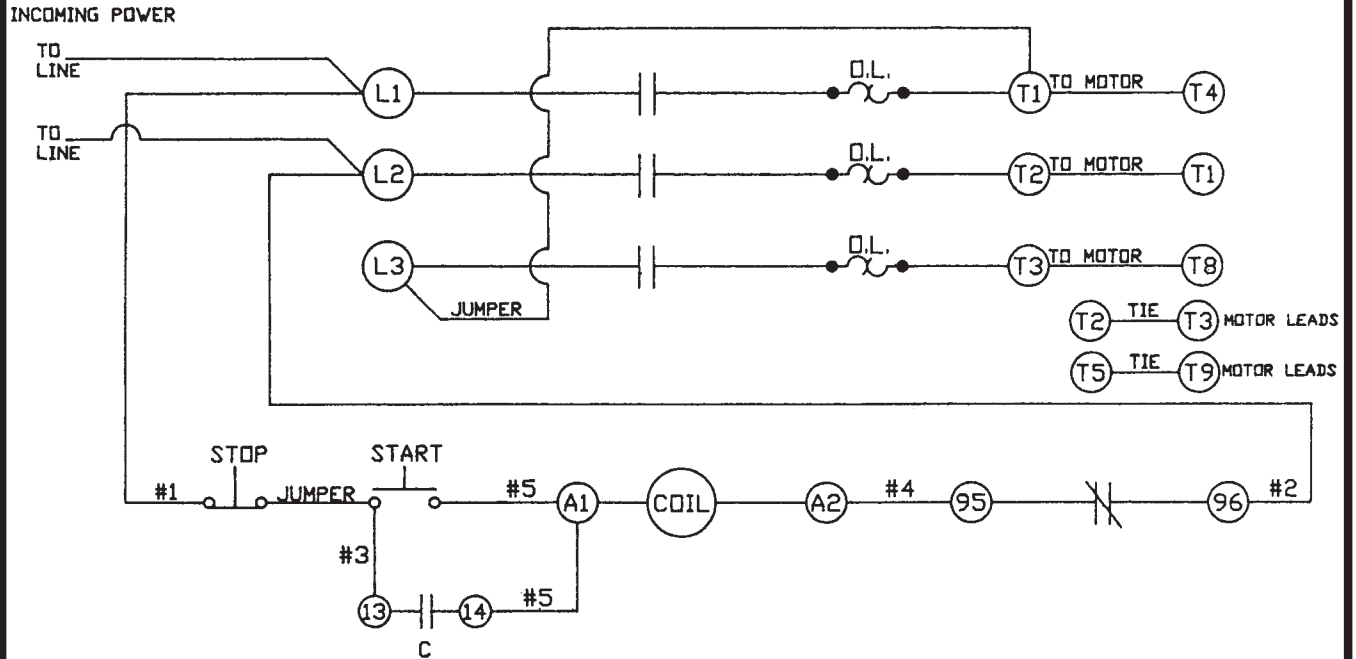

- 230 Volt with 6 Motor Leads -

**Model 3334 Schematic Using 3-Pole Stromberg or AEG W.T. Switch
for 230 Volts, Single Phase, 60 Cycle Baldor Motor with 6 Motor Leads
TO ELIMINATE BREAKING EFFECT OF MOTOR AFTER STOP IS ENGAGED**

*To Reverse Rotation
Interchange Leads 5 & 8

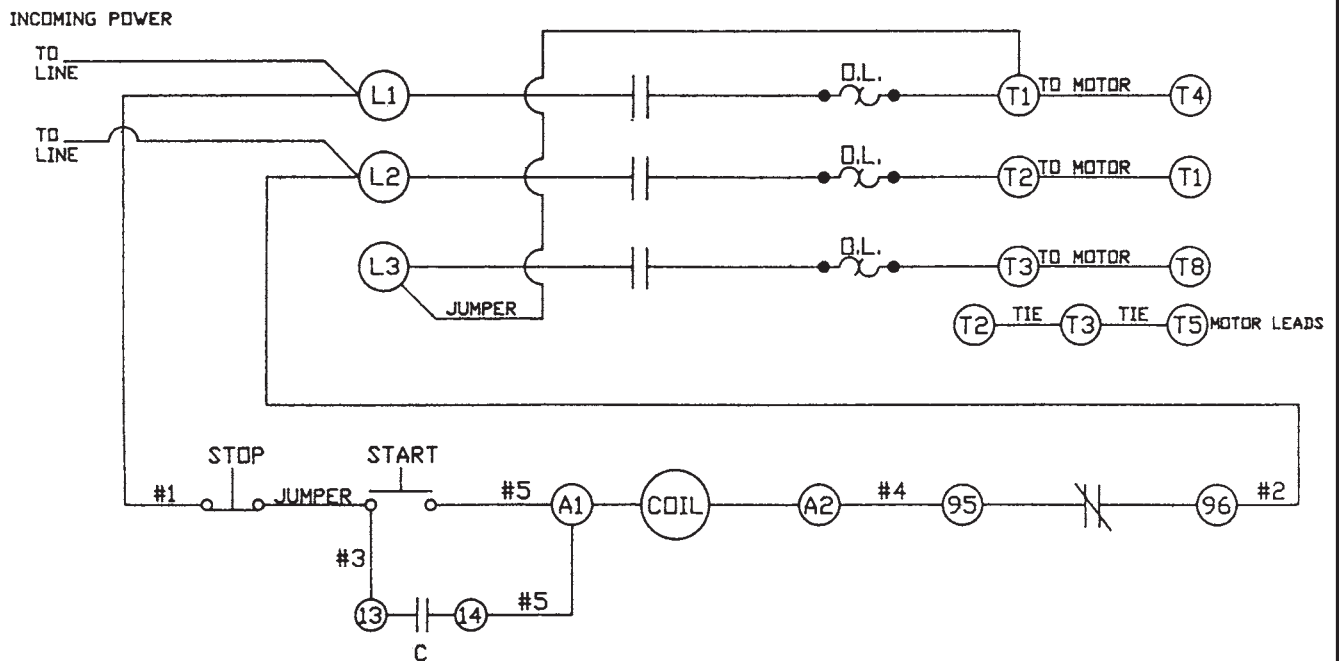

- 208/220/440 WITH 3 PHASE MOTOR -
Model 3334 Schematic Using 3-Pole Stromberg or AEG W.T. Switch
for 208-220/440 Volts, Three Phase, 60 Cycle US or Baldor Motor

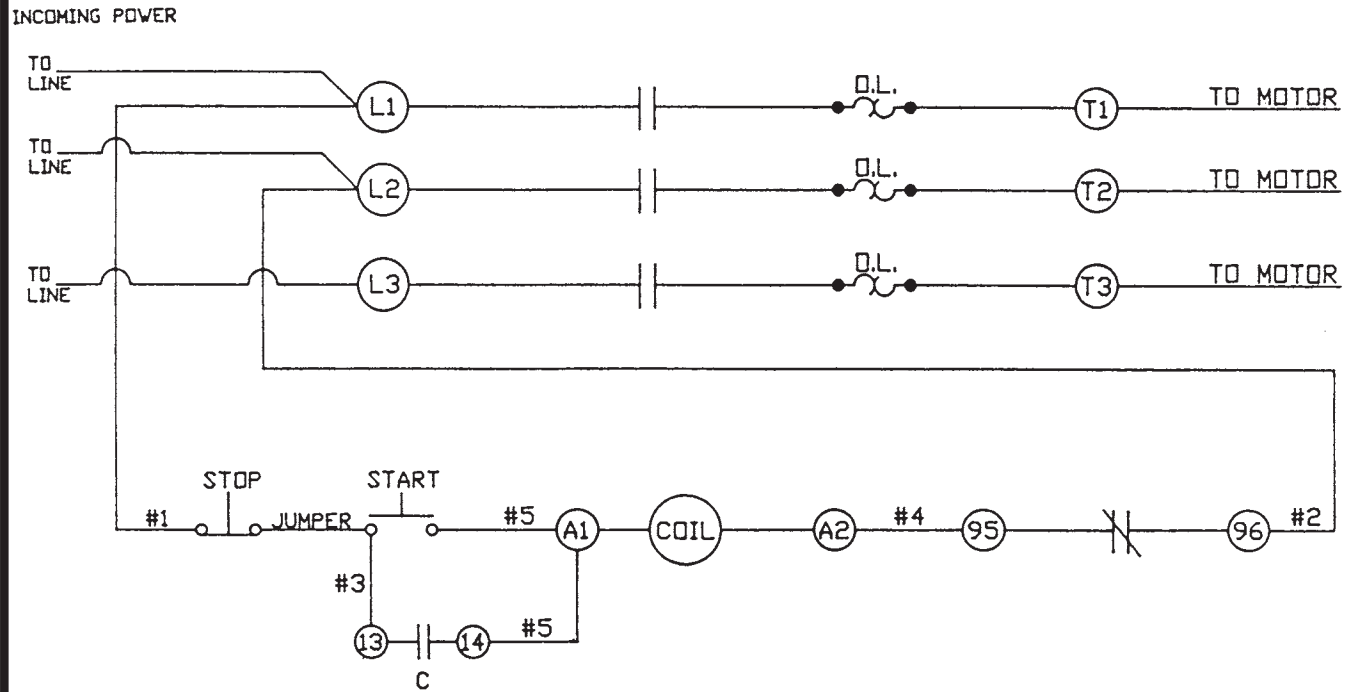

MODEL 3334 PARTS NUMBERS AND DESCRIPTIONS
SEND IN MODEL NO. AND SERIAL NO. WHEN ORDERING PARTS

Item No.	Description	Item No.	Description
AN15S	Acorn nut, 1/4-20, SS	RHS25S	Round head screw, 1/4-20 x 3/4, SS
FW05S	Flat washer, 1/4, SS	RHS30S	Round head screw, 1/4-20 x 7/8, SS
FW07S	Flat washer, 3/8, SS	S1007	Channel bracket, SS (3334-4003 only)
FW08S	Falt washer, 3/8 ID x 1OD, SS	S11	Ratchet trigger
FW10S	Flat washer, 5/16, SS	S1120EZ	Channel, SS (3334-4003 only)
FW15S	Flat washer, 1/2, SS	S12214	Platter bracket starting with S/N 24464*
HHS003S	Trimmed hex head screw, 5/32 x 1/4, SS	S155-11	Meat carr stop thumb screw
HHS005S	Hex head screw, 10-32 x 3/8, SS	S155B	Meat carriage stop welded
HHS010S	Hex head screw, 5/32 x 1/2, SS	S155EZ-3	Hex standoff, EZ flow carriage
HHS015S	Hex head screw, 10-32 x 7/8, SS	S16005C	Head, SS
HHS020S	Hex head screw, 1/4-20 x 3/8, SS	S16006	Head door, SS
HHS025S	Hex head screw, 1/4-20 x 1/2, SS	S16007	Channel bracket SS
HHS035S	Hex head screw, 1/4-20 x 5/8, SS	S16015-1	Motor baseplate adjusting stud, SS
HHS040S	Hex head screw, 1/4-20 x 3/4, SS	S16120	Channel stainless steel
HHS049NL	Hex head screw, 5/16-18 x 1/2, nylon	S16217L	Base door left panel SS, see page 23
HHS050S	Hex head screw, 5/16-18 x 3/8, SS	S16217LTP	Base door left tapered panel, SS, see page 23
HHS055S	Hex head screw, 5/16-18 x 3/4, SS	S16217R	Base door right hinged SS
HHS060S	Hex head screw, 5/16-18 x 1, SS	S16239-5	Base, stainless steel
HHS070S	Hex head screw, 3/8-16 x 1, SS	S16273	Meat gauge bracket SS
HHS075S	Hex head screw, 3/8-16 x 1 1/4, SS	S16275	Meat gauge plate, SS
HN05S	Hex nut, 8-32, SS	S16290	Cleaning unit stamping SS
HN10S	Hex nut, 10-32, SS	S16296-8	Switch brkt Kroger 800S2SA4
HN15S	Hex nut, 1/4-20, SS	S16335X	Upper wheel hinge plate, SS
HN20S	Hex nut, 5/16-18, SS	S181155AEZ	Meat carriage angle, EZ flow (3334-4003 only)
HN25	Hex nut, 3/8 x 16	S18155EZ-1	Carriage top w/weld studs (3334-4003 only)
HN25S	Hex nut, 3/8-16, SS	S189	Ratchet arm stud, stainless
HN30S	Hex nut, 3/8-16, light jam, SS	S19	Ratchet base, stainless
HN35S	Hex nut, 3/8-16, SS	S200B1	Stopstud gde bar & crg stp SS
LH663	Left hand saw guard	S217C	Base door hinge pin long SS
LW05S	Lock washer, #10, SS	S217E	Base door hinge pin short SS
LW10S	Lock washer, 1/4, SS	S229	Wheel cleaner arm torsion spring, SS
LW15S	Lock washer, 5/16, SS	S235	Taper pin, stainless, 4 x 3/4
LW20S	Lock washer, 3/8, regular, SS	S239-B30	Base foot welded, SS
LW25S	Lock washer, 3/8, SS	S239-B40	Base leg, welded
M55-G54313-U	Motor, 2HP 208/220/440-50/60-3, open	S239-B41	Hex leg, adjustable
M68-67385-D	Motor, 2HP, 208/220/440-50/60-3, TE	S240	Ratchet trigger spring
M701-G57011-U	Motor, 3HP, 208/220/230/440-50/60-3, TE	S244	Wheel cleaner arm stud SS
RHS20S	Round head screw, 10-32 x 1 1/8, SS	S253	Upper wheel aligning screw, SS
RHS10S	Round head screw, 10-32 x 3/4, SS	S262	Meat gauge release handle

MODEL 3334 PARTS NUMBERS AND DESCRIPTIONS (Cont.)

Item No.	Description	Item No.	Description
S268	Stationary bar hdless screw, SS	17211-22	Finger lift shim .022
S295	Wheel cleaner arm, stainless	17211-35	Finger lift shim .035
S325	Wheel cleaner washer, SS	175-1-S	Thumb guard nut, SS
S360CB-1	Carriage bit $\frac{3}{8}$ -16 x $1\frac{1}{4}$ SS	175-2-S	Thumb screw $\frac{1}{8}$ -20 x $\frac{1}{2}$
S415D	Stainless stationary bar	175S	Thumb guard, nylon
S416	Platter locator weld pin, SS	18120EZ-B3	Guide bar, EZ flow
SSS05S	Set screw, 10-24 x $\frac{3}{8}$, cup point, SS	211D	Finger lift fastener bolt $\frac{3}{8}$ -16 x $1\frac{3}{4}$
SSS15	Set screw, cup point, $\frac{5}{16}$ -18 x $\frac{5}{16}$	221-(size)	V-belt
SSS20	Set screw, cup point, $\frac{3}{8}$ -16 x $\frac{3}{8}$	226-28	Cndt conctrwshr $1\frac{1}{2}$ x $2\frac{1}{2}$ SS
10-1	Ratchet arm	228-2	Lwr sawguide wshr, $\frac{1}{4}$ x $\frac{7}{8}$ x $\frac{1}{16}$
111AL	Tension spring pin, ALI.	230DL	Upper shaft seal, double lip
112-212	Waved washer, $\frac{21}{64}$ ID, $\frac{5}{8}$ OD	231DL	Lower shaft seal, double lip
116-22	Saw guide bar 22 inch	234	Grease fitting upper wheel
118	Tension spring plate	237	Up shaft castellated lock nut
119A	Saw guide stationary bar	238	Up shaft castld lock nut washr
119AFSC	Saw guide stationary bar fish	239-B31-2	Pipe leg, aluminum, 6"
130	Saw cleaner bracket, rear	239-B32-AR	Pipe leg cap
131	Saw cleaner SS	239-B34	Replaced by AS239-B30-B*
14362	Bearing adj. cap	S240	Ratchet trigger spring
14544	Grease seal	242R	Base door lock, right
14545	Ret. ring, internal	247	Upper shaft
14548	Grease seal	248	Upper wheel hub cap
14746	T-handle lock, removable lower wheel	249	Base door handle
14GP	Head door hinge pin long $1\frac{1}{2}$	252X	Shaft lock nut
14GP-1	Head door hinge pin short $1\frac{1}{4}$	256P	Safety pusher plate, compostn
14TH	Head door hinge	256PM	Safety pusher plate, aluminum
16Z	Lower gde brkt saw clnr holder	259	Anti-short bushing, $\frac{1}{2}$
16001	Upper main bearing spacer	260	Aluminum slide gib
16003-6	Lower saw wheel 16 inch, 6 spoke	264-1	Meat gauge hand wheel
16003U-6	Upper saw wheel 16 inch, 6 spoke	264G	Meat gauge hand whl groove pin
16005	Head, aluminum	265	Meat gauge release spring
16005-1	Ratchet shield on head	267	Meat gauge release cotter key
16006	Head door (use A16006)	270	Meat gauge release pin
16015-10	Motor base plate, 1 ph	271AL	Meat gauge worm gear
16015-11	Mtr bseptl, spec. TE FRM145T, SS	272-6-S	Meat gauge bracket wing nut
16015-12	Motor base plate, spec. Norway	272-7	Knob, 4-point, $\frac{5}{16}$ -18
16015-2	Motor base plate stud nut	272-8	Cap nut, $\frac{5}{16}$ -18, SS
16015-3	Motor base plate wing nut	272-9	Hex bolt, $\frac{5}{16}$ -18 x 2, SS
16015-4	Motor base plate lock washer	272-13	Hex bolt, meat gauge bracket
16112	Head door latch	272-14	Castle nut, $\frac{5}{16}$ -18, SS
16132	Saw cleaner brkt holder rear	277	Lower shaft key
16154	Table extension, SS	280	Motor shaft key
16155	Meat carriage top & angle	296	Toggle switch bracket, $1\frac{1}{2}$ HP mtr
16155-13	Carriage stop angle SS	296-3	Sw brkt ACW, BCW, AAA1, TAA1, 2HP mtr & up
16155-2A	Meat carriage guide	300	Lower shaft woodruff key
16155-2B	Meat carriage guide spacer $\frac{1}{64}$	310	Washr move carr stp headdr lck
16155-2C	Meat carriage guide spacer $\frac{1}{32}$	311	Rubber bumper
16159	Meat carriage bearing	311-1	Rubber bumper
16163A	Platter hold down clip	324	Motor shim $\frac{1}{16}$ " thick
16163B	Platter neck guard, SS	324A	Motor shim $\frac{1}{8}$ " thick
16163B-1	Platter neck guard, England	340	Star lock washer
16197	Tension spring gauge	360A1	Lower brg hsgng angl grease fitting
16200	Carriage stop movable	360B	Lower brg hsgng tilt set screw
16212	Platter latch	362	Lower bearing housing cap
16220-1	Carriage stop fixed	374	Shell Cassida grease EPS-2
16226A-5	Switch button plate rivet	375	Drive screw, name & model plate
16226A-6	Switch button speed nut	376	Drive screw #10 x $\frac{1}{2}$, SS
16226A-8	Switch buttonhole filler plate	4-30AL	Motor pulley 5 x $\frac{3}{4}$, aluminum
16232	Scrap bucket	415D	Stationary bar
16239-16	Base interlock plte, SS, England	416	Platter locator weld pins (use S416)
16251AL	Upper v-belt pulley 11.4 x 1, aluminum	513	Upper wheel hub gasket
16251-90X78AL	Upper pulley 9 x $\frac{7}{8}$	530	Retaining ring (replaces 16001) 22164 on
16272	Meat gauge gear rack	601	Upper saw guide bracket
16275	Replaced by A16278	602B	Saw guide, upper
16278	Meat gauge arm	602AFSC	Saw guide upper bracket, fish
16296-2	Switch bracket, SS	605	Saw guide, lower blade back-up
16301	Name & model plate (Ser. No. required)	609AAW	General purpose switch, 1 & 3 ph
16302	Saw blade 124 inch	653PC-E	Warning label, English
16303	Lower shaft nut	653PC-S	Warning label, Spanish
16313-100	Operating manual	661-1	Saw guard to head door
16360	Lower bearing housing	663	Saw guard on saw guide bar (if before S/N 12242, also supply #116-22 & #661-1)
16361	Lower shaft	6808-G	Toggle switch, 1 ph
16501	Motor mount, rubber, 1 ph	71-1	Upper wheel hinge bracket SS
16502	Motor mount washer, 1 ph	708	Saw guard safety decal
16503	Motor mount bolt 3 inch, 1 ph	710	Decal, "Blade Tension"
16508	Motor mount star washer 1 ph	7810-G	Toggle switch, 3 ph
16517	Inner race spacer		
16543	Lower shaft, removable wheel		
16547	Lower brg. hsg. removable wheel		
16560	Lower wheel, 16", 6 spoke, removable		
16700	Parts repair kit		
17-3	Engrlift wshr, $\frac{9}{16}$ x .276 x .104, use FW05S		
		*NOTE	Stainless steel (S12214) side platter kits available before Ser. No. 24464 — check with Biro Service Dept.

COMPLETE ASSEMBLIES FOR MODEL 3334

Item No.	Description	Item No.	Description
AS1120EZ	Channel assembly w/center guide (3334-4003 only)	A16200	Channel stop assem movable
AS16005	Head & door assembly	A16220-1	Channel stop assembly fixed
AS16006	Head door assembly, SS	A247-1	Up shaft brg assem without wheel
AS16120	Channel assembly, SS	A16278	Meat gauge plate assembly less release assembly
AS16273-275	Meat gauge assembly	A16335X	Hinge plate assembly
AS16275	Meat gauge plate with release assembly	A16360	Lower bearing housing assembly
AS16290	Cleaning unit stamping assembly, SS	A16361	Lower shaft bearing assembly
AS239-B30-B	Bolt-on base foot & leg assembly w/fasteners	A16547	Lower bearing housing assembly, removable wheel
AS415D	Stationary bar assembly SS	A181155EZ	Meat carriage assembly w/center guide (3334-4003 only)
A116-22AL	Saw guide bar assembly 22" – aluminum	A19-1	Ratchet assembly
A116-22SS	Saw guide bar assembly 22" – stainless	A175S	Thumb guard assembly
A130	Steel cleaner assembly	A211-AL	Finger lift assembly, removable – aluminum
A16Z	Guide brkt saw cleaner assem	A211-SS	Finger lift assembly, removable – stainless
A16003U-6	Up wheel assem without hinge plate	A227	Up bearing cup/cone assembly
A16003U335-6	Up wheel assem with hinge plate	A249R	Base door handle assem, right
A16005	Head & door assembly	A260	Aluminum slide gib assembly
A16006	Head door with hinge assem	A262	Meat gauge release assembly
A16014L	Head door hnge assem, lwr, shrtprn	A295	Wheel cleaner assembly
A16014U	Head door hnge assem, upr, lngprn	A363	Lower bearing cup/cone assem
A16112	Head door latch assembly	A415D	Stationary bar assembly
A16132	Steel cleaner assembly, rear	A602	Saw guide assembly, upper
A16155	Meat carriage assembly	A661-1	Saw guard on head door assembly
A16163-1	Stationary platter assembly	A71-1	Upper wheel hinge bracket assembly
A16163-E	Stationary platter assembly, England		
A16163-M	Platter assembly, Govt., Size 2		
A16196	Tension spring assembly		

MODELS EQUIPPED WITH STAINLESS STEEL FABRICATED HEADS

Stainless steel heads became available (as optional equipment) starting with Ser. #23265. From Ser. #23265 to Ser. #25059 and starting again with Ser. #36272, these stainless steel heads were mated to the base structure in the same fashion as the aluminum head using the Item #260 slide gib. From Ser. #25060 to Ser. #36251 the machined blocks were eliminated and the slide gibs redesigned to a dovetail configuration to secure the head.

(The Factory Does Not Recommend Field Conversions)

PARTS EXCLUSIVE TO 3334SS WITH OPTIONAL STAINLESS STEEL HEAD STRUCTURE

Item No.	Description	Item No.	Description
S16005	Head, SS, 1st design, ser. #23265 to Ser. #25059, replaced by S16005C	S16006	Head door, SS, all SS heads
S16005B	Head, SS, 2nd design, Ser. #25060 to Ser. #36251, (uses dovetail slide gibs) replaced by 1 ea. #S16005C and 2 ea. #260	16260ZA	Slide gib, dove tail type, Serial #25060 to Ser. #36251, no longer available
S16005C	Head, SS, current design, Ser. #36272 to present, (uses #260 slide gibs)	16662	Saw guard on saw guide bar, SS all SS heads

THE *BIRD* MANUFACTURING CO.
MARBLEHEAD, OHIO 43440

BIRD WEARABLE SAW PARTS THAT WILL FIT BIRD POWERCUTTERS
MODELS 11, 1433, 33, 3334, 44, 4436, & 55

-EXCEPT WHERE NOTED OTHERWISE-

CONTACT YOUR NEAREST BIRD AUTHORIZED DISTRIBUTOR,
OR CALL BIRD MANUFACTURING PH. (419) 798-4451

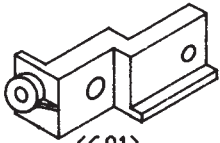

(601)
UPPER SAW
GUIDE BRACKET



(S608)
LOWER SAW GUIDE
BACK-UP GUIDE
WITH CARBIDE
22-1433-55
AFTER 35300



(179)
WHEEL
CLEANER



(S244)
WHEEL
CLEANER
ARM STUD



(119A)
LOWER
SAW
GUIDE

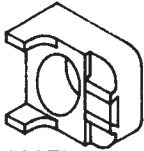

(605)
LOWER SAW BLADE
BACK-UP GUIDE
(34-3334-44)



(S229)
WHEEL CLEANER
ARM SPRING



(S265)
MEAT GAUGE
SPRING

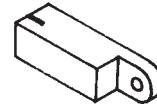

(177)
NYLON
FILLER
BLOCK

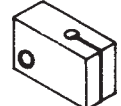

(602B)
UPPER SAW
GUIDE WITH
BEVELED
CARBIDE

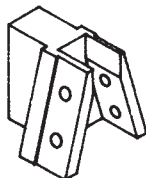

(130)
SAW CLEANER
BRACKET
NOT USED ON
MOD. 1433 OR
MOD. 55



(131)
STEEL
BLADE
CLEANER



(16159)
CARRIAGE
BEARING
1433-34-3334
44-55



(159)
CARRIAGE
BEARING
11-22-33

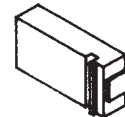

(604)
LOWER SAW BLADE
BACK-UP GUIDE
11-22-33
BEFORE (35300)



(S268)
FILLER &
GUIDE STUD

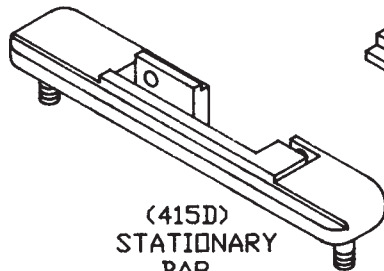

(415D)
STATIONARY
BAR

(OBSOLETE)

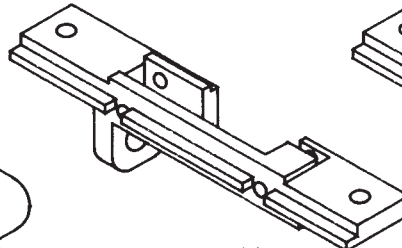

(S415D-2)
STAINLESS STEEL
STATIONARY BAR
22-1433-55
(AFTER 35300)
(OBSOLETE)

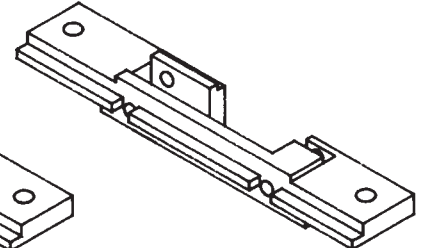

(S415D)
STAINLESS STEEL
STATIONARY BAR

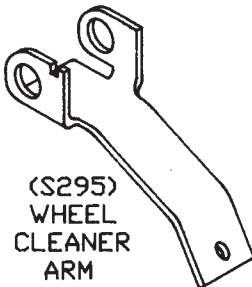

(S295)
WHEEL
CLEANER
ARM

- USE PARTS REPAIR KIT PART NO. 16700 -

WARNING LABEL LOCATIONS ON MACHINE



WARNING



DO NOT Use Unless Trained and Authorized By Supervisor And Over 18 Years Old.
Read Operation Manual Thoroughly Before Operating.
ALWAYS Keep Hands Clear of Saw Blade and Other Moving Parts. Turn Off Saw when Finished Cutting.
ALWAYS Keep Blade Guard Adjusted to 1/2" Above the Product being Cut.
ALWAYS Use End Cut Pusher Plate When Cutting Smaller Piece of Product.
DO NOT Use Saw if it is Altered, Damaged, Improperly Maintained, or If Warnings Are Illegible or Missing.
ALWAYS Disconnect and Unplug from Main Power Source and Perform LOCKOUT/TAGOUT Before Cleaning or Servicing.

#653PC-E

Item No. 653PC-E

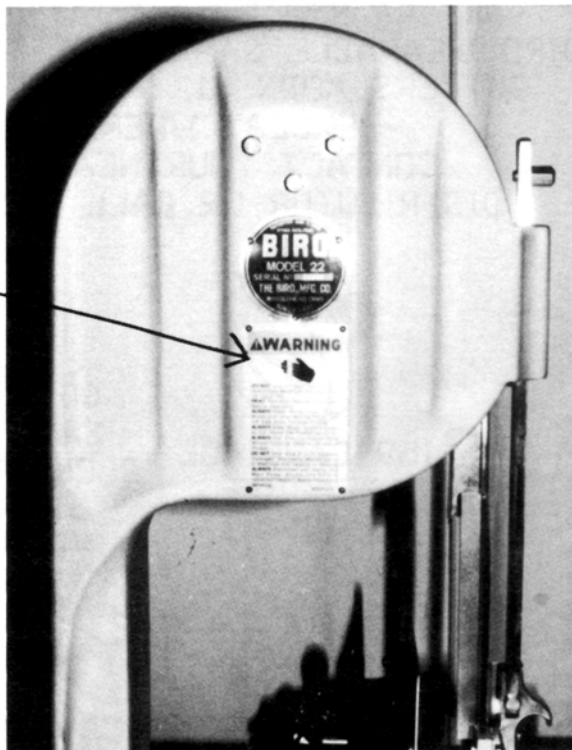

ATTACH ON HEAD STRUCTURE BELOW
MODEL/SERIAL NUMBER TAG

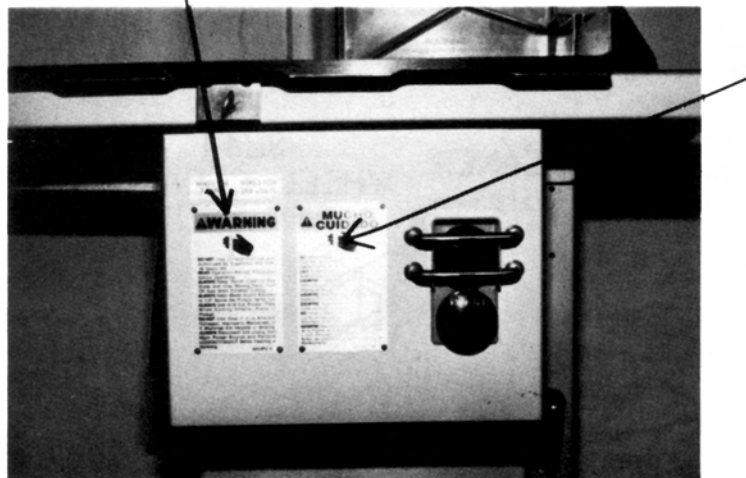

ATTACH TO CHANNEL BRACKET NEXT TO
SWITCH CONTROL BUTTONS



MUCHO CUIDADO



NO Opere Esta Sierra Sin Haber Sido Entrenado Para Ello Ni Tampoco Sin Autorizacion de un Supervisor. Uno Tiene que Haber Cumplido 18 Anos Para Operarla.
LEA Cuidadosamente el Manual de Operacion Antes de Usar Este Equipo.
SIEMPRE Guarde las Manos a Salvo de la Hoja de Serrar y de Otras Partes Moviles. Cierre el Interruptor Despues de Terminar de Cortar.
SIEMPRE Tenga Ajustado el Guardasierra Para que Quede a 1/2" Por Encima del Producto que se Corta.
SIEMPRE Haga Uso de la Place de Empuje Para Cortes de Extremos al Cortar Trocitos Pequenos.
NO Utilice la Sierra si se Halla Alterada, Danadao si No ha Sido Debidamente Mantenido o si la Advertencia es Alegible o si Falta Esta.
SIEMPRE Desconecte el Equipo Decenchifandolo de la Fuente de Fuerza. Dejelo Bajo Llave o con Etiqueta que Prohiba su Uso Antes de Limpiarlo o Hacer Trabajos de Mantenimiento.

#653PC-SP

Item No. 653PC-SP

WARNING LABEL LOCATIONS ON MACHINE



ATTACHED TO SAW GUARD
ON SAW GUIDE BAR

P/N 708 "DANGER EXPOSED
BLADE" DECAL

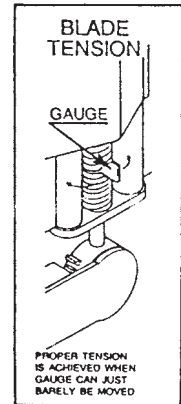

P/N 710 "BLADE
TENSION" DECAL
ATTACH TO HEAD
DOOR AS SHOWN



** This saw has been equipped with a "REMOVABLE" lower wheel **

ATTENTION: ELECTRICIAN / SERVICE TECHNICIAN
** READ FIRST BEFORE STARTING POWER CUTTER **

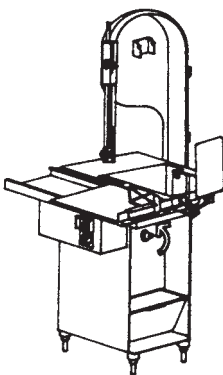

IMPORTANT

This saw has been electrically tested at the factory, but electrical phasing for proper rotation may not match your electrical supply.

WITH LOWER SAW WHEEL REMOVED, check rotation of shaft. Rotation must be counterclockwise when facing shaft. Failure to confirm correct rotation could result in the wheel dislodging.

ATTACH TO HINGED
RIGHT BASE DOOR

P/N 16716 CAUTION LABEL
USE ON MACHINES WITH
REMOVABLE LOWER WHEEL

— NOTES —

LIMITED WARRANTY:

WARRANTY: The BIRO Manufacturing Company warrants that Model 3334 Power Cutter will be free from defects in material and workmanship under normal use and with recommended service. BIRO will replace defective parts, which are covered by this limited warranty, provided that the defective parts are authorized for return, shipping charges prepaid, to a designated factory for inspection and/or testing.

DURATION OF WARRANTY: The warranty period for all parts covered by this limited warranty is one (1) year from inspection/demonstration advised on the returned Warranty Registration card, or eighteen (18) months from original factory ship date, whichever occurs first, except as noted below.

PARTS NOT COVERED BY WARRANTY: The following are **not** covered by this limited warranty: steel saw cleaners, item number 131; wheel cleaners, item number 179; steel guide, item number 119A; upper saw guide, item number 602B; lower back guide, item number 605; nylon filler, item number 177. This limited warranty does not apply to machines sold as used, rebuilt, modified, or altered from the original construction in which the machine was shipped from the factory. (Water contaminated electrical systems are not covered under this limited warranty.) BIRO is not responsible for electrical connection of equipment, adjustments to switch components or any other electrical requirements, which must be performed only by a certified electrician. BIRO is not responsible for service charges or labor required to replace any part covered by this limited warranty or for any damages resulting from misuse, abuse, lack of proper or recommended service.

EXCLUSION OF WARRANTIES AND LIMITATION OF REMEDIES: BIRO gives no warranties other than those expressly stated in this limited warranty. THE IMPLIED WARRANTY OF MERCHANTABILITY, THE IMPLIED WARRANTY OF FITNESS FOR PROCESSING FOOD PRODUCTS, AND ALL OTHER IMPLIED WARRANTIES ARE SPECIFICALLY EXCLUDED. BIRO IS NOT LIABLE FOR CONSEQUENTIAL OR INCIDENTAL DAMAGES, EXPENSES, OR LOSSES. THE REMEDIES PROVIDED IN THIS BIRO LIMITED WARRANTY ARE PURCHASER'S SOLE AND EXCLUSIVE REMEDIES AGAINST BIRO.

REGISTRATION CARDS: You must sign, date and complete the warranty registration card supplied with each machine. The warranty card must be returned to The Biro Manufacturing Company for proper registration. If no warranty card is returned to BIRO, the warranty period will begin from the date the machine was originally shipped from the factory.

HOW TO GET SERVICE:

1. Contact the agency from whom you purchased the machine; or
2. Consult the yellow pages of the phone directory for the nearest authorized dealer; or
3. Contact BIRO Mfg. Company for the nearest authorized service entity (250 plus worldwide) in your area.

THE BIRO MANUFACTURING COMPANY

1114 Main Street
Marblehead, Ohio 43440-2099
Ph. 419-798-4451
Fax 419-798-9106
E-mail: service@birosaw.com
Web: <http://www.birosaw.com>