

# The Domino S300

*Extremely compact scribing laser designed for high speed coding on a wide range of surfaces including PET, glass and labels*

## Code Quality Re-defined

- ◆ Letter quality text and graphics allow codes to compliment product packaging even at high speed
- ◆ Codes on PET are sharp and easily read with a “frosted” appearance

## Compact

- ◆ Having the smallest and lightest laser head in its class, at 8.6Kg (19lb), the S300 is one of the easiest to install allowing coding of products inside existing equipment guarding in many applications
- ◆ The control cabinet provides an intuitive touch screen user interface together with quick fit connectors for essential accessories ensuring easy integration

## Outstanding performance

- ◆ Micro laser technology with optimised optics and software gives the S300 the ability to code at high production speeds over a large print area
- ◆ Two lines of code can be produced at speeds in excess of 1,000 bottle per minute on PET, and 152 m/minute (500ft/min) on labels
- ◆ Single line codes can be produced on glass at speeds of over 122 m/min (400ft/min)

## Extreme Reliability

- ◆ Compact laser tubes and optics combined with pressurised air cooling means that small is also reliable
- ◆ The sealed IP55 laser head and controller are suitable for use where dust or water are daily hazards



Change your view on code quality



The compact laser head makes installation simple even inside existing guarding



Crisp permanent codes on a wide range of surfaces including those that are traditionally hard to mark

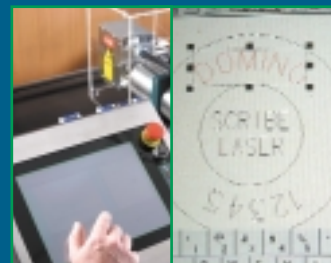

Large colour touch screen and WYSIWYG operator software make code design quick and error free

# The Domino S300

## S300 Technical Specifications

<b>Laser Type</b>	Sealed CO <sub>2</sub> Laser		
<b>Laser Power</b>	S300 = 35W, S300B = 30W		
<b>Marking Features</b>	Characters per Second 800* Product Line Speed Up to 305 m/min* (1000 ft/min*) Marking Field/Focal Length 56x56mm (2.2"x2.2"), Focal Length 89mm (3.5") 76x76mm (3.0"x3.0"), Focal Length 127mm (5.0") Laser diode aiming beam to indicate mark area Number of lines of text As many as required Character Height 0.8 – 76mm (0.03"-3.0") Fonts 24 fonts, multi-language, including Asian characters Marking Options Text, logos, bar codes, 2D codes, graphics, automatic serial numbering, batch coding and real time clocks		
<b>User Interface</b>	12.1" colour touch screen with WYSIWYG and SVGA quality (800*600 resolution) display Control language in English, German, French, Spanish, Dutch, Danish, Polish, Portuguese, Italian, Hungarian, Korean, Russian, Swedish, Chinese (Simplified & Traditional) and Japanese		
<b>Operating System</b>	Microsoft Windows ® 2000		
<b>Laser Head</b>	Length 688mm (27.09")	Height 167 mm (6.57")	Width 107mm (4.21")
			Weight 8.6kg (19lb), 10.9 Kg (24lbs) with 3m conduit
<b>Control Cabinet</b>	Width 394mm (15.51")	Depth 467mm (18.39")	Height 349mm (13.74")
			Weight 18Kg (40lbs)
<b>Construction</b>	Stainless steel for laser head and control cabinet		
<b>Conduit Length</b>	3m (9.85ft), 6m (19.69ft) optional		
<b>Inputs &amp; Outputs</b>	Product Detect Inputs NPN/PNP/5-24Vdc – Sensor Product Speed Detect Quadrature Shaft Encoder Signal Inputs External E-stop, interlock circuits, cooling air monitor, fume extraction monitor, 9 configurable user inputs Signal Outputs Alarm, ready signal, fume extraction control, cooling air solenoid control, E-stop status, print complete, 3 configurable user outputs Interfaces 3.5" Floppy Drive, PS2, VGA, RS232, Ethernet, USB, IDE		
<b>Electrical Requirements</b>	90-264 VAC, 47-63Hz, 600VA typical		
<b>Environment</b>	Cooling Compressed air required typically 7 SCFM (200 litres/min) duty cycle and ambient temperature dependent Environmental Standard IP55, CE mark Operating Temperature 5 to 45°C (41 to 113°F) Operating Humidity 10-95% non-condensing Options Laser head mounting bracket, control cabinet stand, alarm beacon, fume extractor, air filtration kit		

\*Character generation and production speeds are substrate and code dependent

## Dimensions

All dimensions in millimetres

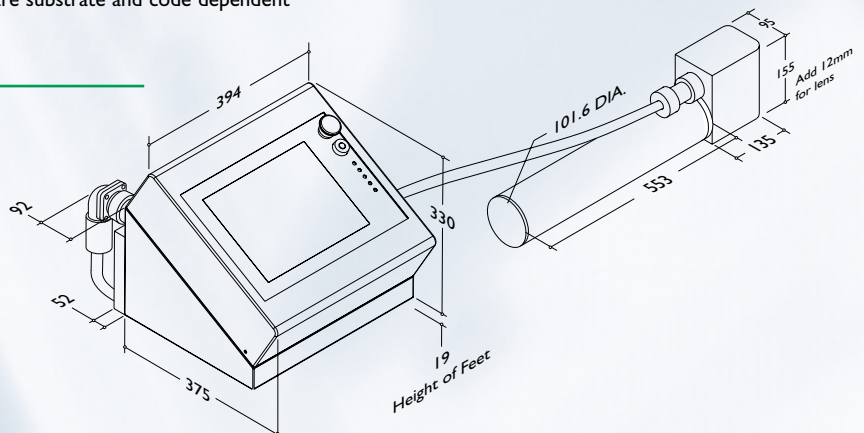

**Domino UK Ltd**  
 Bar Hill  
 Cambridge CB3 8TU UK  
 Tel: +44 (0)1954 782551  
 Fax: +44 (0)1954 782874  
 Web: www.domino-printing.com

**Domino Amjet Inc.**  
 1290 Lakeside Drive USA  
 Gurnee, Illinois 60031  
 Tel: +1 847 244 2501/2  
 Fax: +1 847 244 1421  
 Web: www.dominoamjet.com

