

## High Resolution Large Character Printing

- **Consistently high print quality - micropurging with every print**
- **Reduced cost of ownership - unique ink-recycling circuit**
- **Easy integration - small, single-unit system with a range of printhead heights**



PRODUCT CODE: <b>46744</b>	THE PASTA Co UNIT 22 INDUSTRIAL ESTATE EAST GREAT BRITAIN	50 X 75G MINIMUM	BEST BEFORE <b>19.06.2008</b>
<b>PASTA SAUCE</b>			
INGREDIENT DECLARATION MUSHROOMS, WATER, DOUBLE CREAM, ONION, MODIFIED WAXY MAIZE STARCH, GARLIC, REEF STOCK, SPANISH ONIONS, COLOUR, SERRANO WHITE WINE, CELERY, MUSTARD, SALT, VEGETABLE OIL, WHITE WINE VINEGAR, LEEK, WORCESTERSHIRE SAUCE, MUSHROOM STOCK, PAPRIKA, FRESH MUSHROOMS, STABILISERS (E412, E415, E416), COLOUR (E150D), BAY LEAF, THYME. <small>THIS PRODUCT MAY CONTAIN TRACES OF NUTS/EGGS</small>		STORAGE: KEEP FROZEN AT -18 C OR COLDER	COUNTRY OF ORIGIN PRODUCED IN THE UK
		EED LICENCE NUMBER <b>SD221RD</b>	SUPPLIER'S INFORMATION <b>9CZ776TER</b>



# High Resolution Large Character Printing

## **The Videojet 2310/2320/2330 printers**

**The Videojet 2300 series printers combine high resolution printing with a simple user interface, making message selection quick, easy and error-free. The Videojet 2300 systems are designed and manufactured to reliably print accurate, high quality, real time alphanumeric codes, bar codes and graphics with a range of printhead heights to best suit your printing needs.**

### **Consistently high print quality — micropurging with every print**

The 180 dpi resolution of the Videojet 2300 series printers allows for complete generic carton coding at pre-printed quality levels. With their unique, self-maintaining printhead system, the Videojet 2300 printers guarantee the highest quality bar codes and printed images on every case, even in the dustiest environments.



These systems can accomplish this because they are the only high resolution ink jet printers that automatically clean and maintain the printhead with a unique, patented micropurging process with every print — without affecting production speed or throughput. Unique technology builds confidence in print quality.

## **Reduced cost of ownership — unique ink-recycling circuit**

You buy ink jet printing equipment to put ink on your packaging – not on your production line or on the floor. Thanks to an unique ink-recycling system, the Videojet 2300s are the only printers where ink used for automatic printhead maintenance is recycled and used for printing after careful filtration. Every drop of ink you paid for goes where you want it – on your packaging. The ink system is air-driven, eliminating potential downtime from maintenance on pumps, solenoids and other moving parts. Efficient use of ink and a mechanically simple system ensure your Videojet 2300 series will always be ready to print the next code without needing human intervention and the associated costs of downtime.

The carton tracking interlock system eliminates the risk of dual marking or uncoded product, and prevents the wasted ink and mess caused by accidental triggering of product photocells. The advanced date checking algorithms found in these printers reduce costly operator date coding errors.

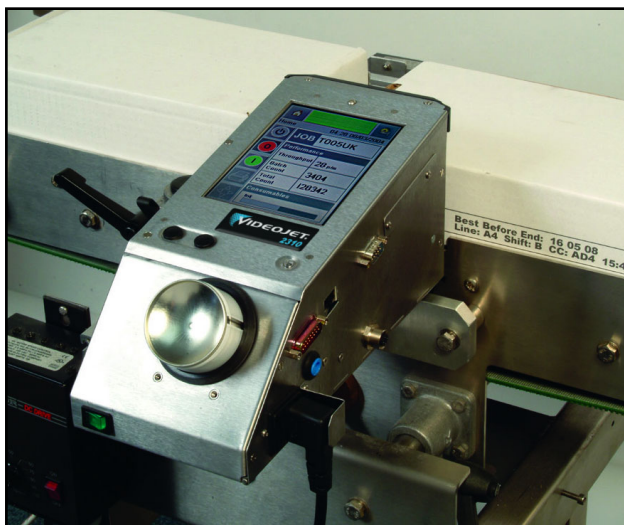
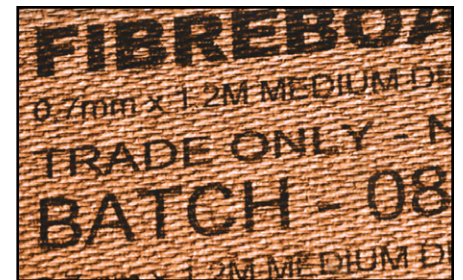
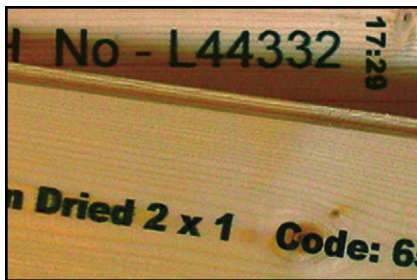

## **Easy integration — small, single unit system**

All of the Videojet 2300 systems consist of a single, compact unit that takes up minimal space on your production line. That single unit contains an intuitive touch screen control system that makes it easy for operators to select the right job without the opportunity for errors created by on line message creation. To enhance flexibility, clusters of Videojet 2300s can be operated from a single master unit. Individual printers or clusters can be controlled remotely from factory IT systems, PLC input or other remote computers through built-in network (TCP/IP and RS-232) capability. Powerful off-board image design provides complete flexibility in message editing and programming, including the full list of TrueType® fonts.

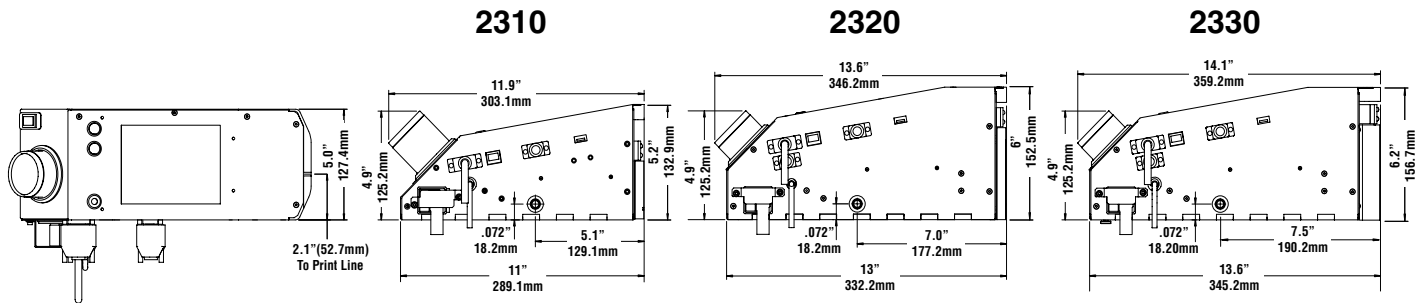

## Specifications

### Technical Specifications

#### Printhead

- 2310:** 17 mm (0.7") high 180 dpi
- 2320:** 53 mm (2.1") high 180 dpi
- 2330:** 70 mm (2.7") high 180 dpi

#### Print Area (per printhead)

- 2310:** 17 mm (H) x 2000 mm (L) (0.7" x 78")
- 2320:** 53 mm (H) x 2000 mm (L) (2.1" x 78")
- 2330:** 70 mm (H) x 2000 mm (L) (2.7" x 78")

#### Number of Printheads

- Up to (4) heads in master/slave mode

#### Self-Cleaning, Self-Prime System

- Standard (patented)

#### Ink Reclaim System

- Standard (automatic)

#### Print Distance

- 0.5 mm to 4.0 mm max. (0.02 - 0.15")

#### Print Speed (resolution, substrate, application and set-up dependent)

- Barcode printing – 0.3 - 31 m/min. (1.0 to 101 feet/min.)
- Alphanumeric text – up to 132 m/min. (433 feet/min.)

#### Ink

- Non-toxic, suitable for food packaging

#### Ink Supply / Delivery

- Non pressurized, screw-in canister

#### Controller / User Interface / Ink cabinet

- Integral to printer

### Inputs / Outputs

#### Integral Print Sensor

- Standard

#### External Inputs

- Print go input (24V PNP or vol-free)
- Encoder input (24V single / quadrature)
- Line select (up to 8 lines)

#### External Outputs

- Fault output (volt-free)
- Warning output (24V PNP)
- Spare (24V PNP)

#### Operator Interface (CLARiTY)

- 5.7" full color LCD

### Services

#### Air Supply Requirements

- 6 Bar, 90psi, dry, un-contaminated

#### Power Supply Requirements

- 90-264VAC, 47-63 Hz, 140VA (max)

#### Operating Temperature

- 10° - 35° C (50° - 95° F)

#### Approvals

- CE/UL60950:2000 (3rd edition)
- Further information available upon request

### System

#### Operator Interface

- Full-color LCD touch-panel CLARiTY interface
- Job selection and database support as standard. WYSIWYG print preview

#### Operator Interface Languages

- Language selection including English, Arabic, Chinese (Mandarin) Danish, Dutch, Finnish, French, Hungarian, Italian, Japanese, German, Greek, Polish, Portuguese, Russian, Spanish, Swedish and Turkish

#### Password Protection

- 3 user-levels

#### Remote Coder Configuration Software

- CLARiTY Configuration Manager
- 'Off-Line' set up and parameter storage available as standard

#### Diagnostics

- On-board diagnostics as standard

#### On-Board Memory

- 128MB memory, CompactFlash®

### Print Capability

#### Image Design Software

- Claricom CLARiSOFT Package Coding Design Software

#### Font Support

- Full downloadable font support for TrueType®

#### Text

- Scalable text including rotation, mirror and inverse printing

### Supported Field Types

- Fixed, variable (user entered), merged, database, counters, date, offsets, time, paragraph (Text Blocks)
- Basic shape drawing (circles, rectangles etc.)

### Special Functions

- Auto real time and date functions
- Auto best before date calculation and concession management
- Auto incrementing & decrementing text, counters and bar codes

### Bar Code Printing

- EAN 8, EAN 13, UPC-A, UPC-E, Code 39, EAN 128, Code 128, ITF, Datamatrix, RSS14, PDF417. Others available upon request.

### Graphics, Images and Logos

- Multiple graphic formats supported using CLARiSOFT. Any size up to maximum print area.

### Day Code Support

- Hour, day of week, day of month, week of year, month of year, year of decade and Arabic date support

### Code Options

- Start of day, shift codes, factory, machine, line ID

### Field Orientation

- 0°, 90°, 180°, 270°

### Networking and External Communications

#### External Data Communications

- RS232 point-to-point communications
- Ethernet 10/100 Base TX network communications
- Binary and ASCII comms protocols and Windows drivers
- Host PC mode (Remote Database) using CLARiNET
- USB connectivity for job download and software updates

#### Master/Slave Functionality

- Group job selection function and group printer control function

#### Network Control Software

- Claricom CLARiNET coder independent network management software



800-843-3610 • www.videojet.com • info@videojet.com

Videojet Technologies Inc. • 1500 Mittel Boulevard

Wood Dale IL • 60191-1073 • USA

Phone: 630-860-7300 • Fax: 630-616-3623

© 2008 Videojet Technologies Inc. – All rights reserved. Videojet Technologies Inc.'s policy is one of continued product improvement. We reserve the right to alter design and/or specifications without notice. Videojet is a registered trademark of Videojet Technologies Inc. TrueType is a registered trademark of Apple Computer, Inc. CLARiTY, CLARiSOFT and CLARiNET are trademarks of Claricom Limited. CompactFlash is a registered trademark of the CompactFlash Association.

Part No. SL000420

2300 Series-0108

Printed in U.S.A.