

# AMF

## GLEN 340 QUART MIXER



- **Planetary Style Bowl Mixer for Use in Bakeries, Institutional Kitchens, Other Food Preparation Centers, and Pharmaceutical Facilities (for Tablet Granulations, Cosmetics, Toiletries, and Abrasive Compounds)**

### FEATURES & BENEFITS

#### Superior Safety and Sanitation

- Stainless steel rotating head assembly, beater drive shaft, locking ring, and mixer guard with safety interlocks
- Mounted NEMA electrical panel and operator controls located on the side of the mixer, with separate pushbutton controls for mixer functions

#### Optional Accessories to Enhance Performance

- Standard and steam-jacketed mixing bowls available
- Custom designed column bowl dumper and stainless steel exhaust hoods also available
- A variety of mixing attachments to meet your production requirements

### MECHANICAL FEATURES

- Heavy duty cast frame
- Stainless steel rotating head assembly, beater drive shaft, and locking ring
- High efficiency main drive gearmotor for dependability and long life
- Gates polychain drive system
- Lexan/stainless steel mixer guard with safety interlocks
- 2 HP raising and lowering motor for rotating head

### ELECTRICAL FEATURES

Operator interface controls on the electrical panel door includes the following:

- Automatic recipe mode for 15 recipes (password protected)
- 5 independent programmable steps for each recipe
- Precise digital timing control
- Manual mode for running single speed with timer
  
- Push button controls for:
  - Start
  - Stop/Emergency stop
  - MCR reset
  - Bowl up/down/stop function

NEMA 4 stainless steel machine mounted electrical enclosure including:

- Main disconnect switch
- Full voltage magnetic NEMA rated starters
- AC Inverter

PLC control

Alarm warning light and horn



Control Panel





## OPTIONS

- Tin spray finish
- Stainless steel cast
- 2-wing stainless steel beater with rubber edge
- 4-wing stainless steel beater with rubber edge
- Stainless steel round whip
- Stainless steel spiral whip
- Bronze dough hook
- 2-wing stainless steel abrasive beater
- Stainless steel mixer guard with safety interlocks in lieu of Lexan
- Stainless steel exhaust hood
- Stainless steel bowl
- Stainless steel steam jacketed bowl
- Cast iron bowl truck
- Additional machine manuals
- Recommended spare parts kits
- CE compliant design
- Explosion proof option per NEC Class 1, Division 1, Group D

### Optional Glen 340 Column Bowl Dumper Features:

- Heavy duty tubular construction
- 4 swivel casters
- 2 waist high handles
- Strategically located floor locks
- Capacity: 1,000 lb. (454 kg)
- Floor level loading
- Quick adjust discharge height
- All stainless steel spiral exterior - 3/16" (5 mm) heavy duty column
- Complete with all electrical controls
- Easy access to all components
- Positive chain lift and return with safety brake
- Variable discharge angle up to 45
- 2 HP gearmotor with electrical brake
- USDA accepted



Optional Column Bowl Dumper

## SPECIFICATIONS

**Bowl Capacity:** 85 gallons/322 liters/11.3 cubic feet

### Electrical Requirements:

Approximate Main Power: 20 KVA

Available in any standard voltage

Equipped with control transformer to provide 115 volt control circuit

### Agitator Speed:

Continuously variable through an AC inverter drive from 45 to 186 rpm (Standard Motor), 12 to 186 rpm (explosion proof)

**Approximate Shipping Weight:**  
6,000 lb. (2722 kg)

**Approximate Shipping Dimensions:**  
84" x 60" x 84"  
(2134 mm x 1524 mm x 2134 mm)

## GLEN 340 QUART MIXER

### DIMENSIONAL DRAWING

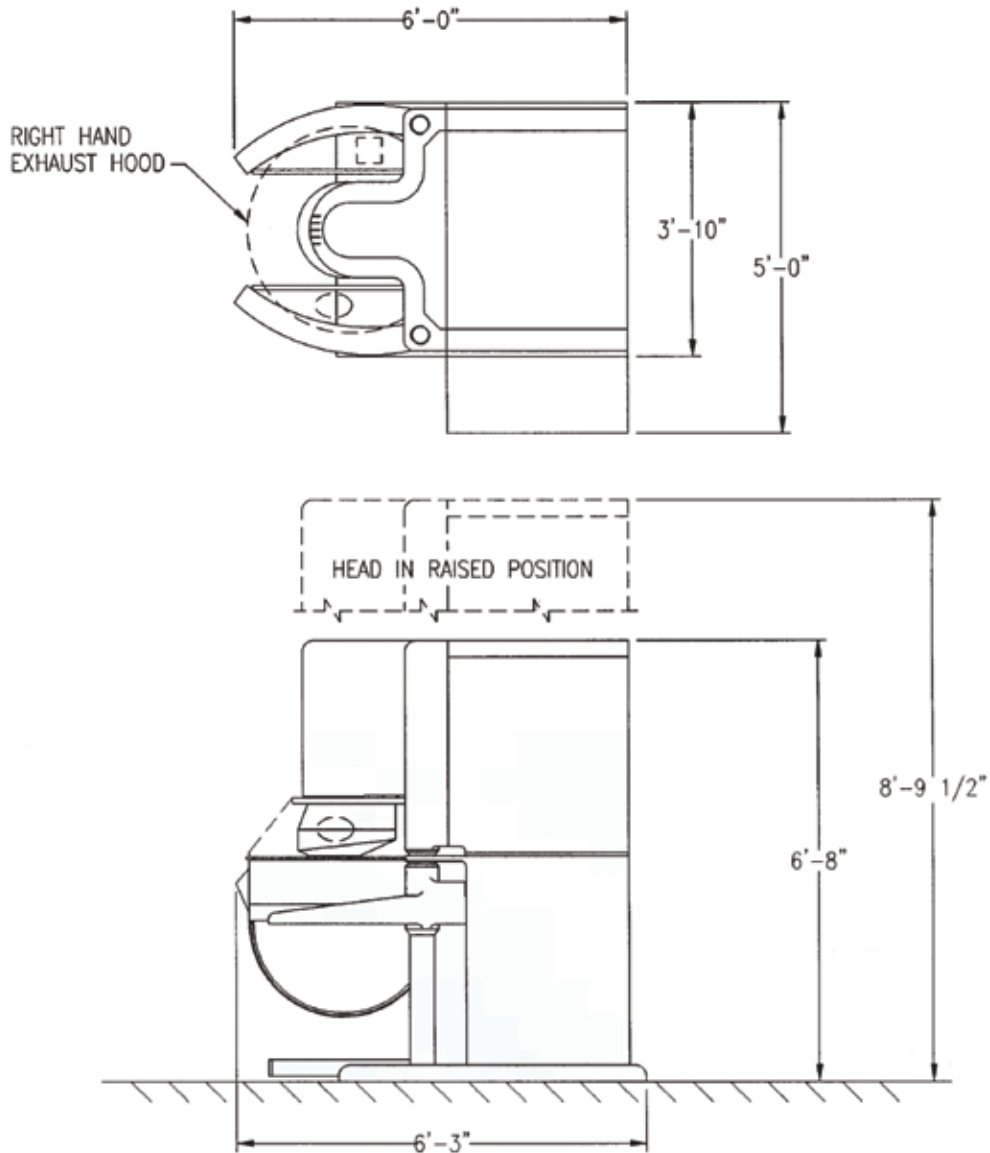

**Headquarters:**  
2115 W. Laburnum Ave.  
Richmond, Virginia 23227  
**Tel: 1-800-225-3771**  
or 1-804-355-7961  
**Fax: 1-804-342-9724**  
[sales@amfbakery.com](mailto:sales@amfbakery.com)

**Europe Office:**  
6 The Sidings  
Station Road, Guiseley  
Leeds LS20 8BX, England  
**Tel: 44-1943-875703**  
**Fax: 44-1943-871806**  
[sales-europe@amfbakery.com](mailto:sales-europe@amfbakery.com)

**Asia Office:**  
2206, A-Bldg.  
No.3 Estate Mansion  
No.1 Shuangxili Rd.  
Beijing, China 100028  
**Tel: 010-58222950**  
**Fax: 010-58222952**  
[sales-asia@amfbakery.com](mailto:sales-asia@amfbakery.com)

FOR MORE INFORMATION PLEASE CALL YOUR ACCOUNT MANAGER OR

**1-800-BAKERS-1**  
**www.amfbakery.com**

AMF's focus on continuous improvement may result in changes to machinery specifications without notice.

AMF is a Markel Bakery Group Company 06/2014