

HELIX

AUTOMATIC ROTATING ARM STRETCH WRAPPING MACHINES

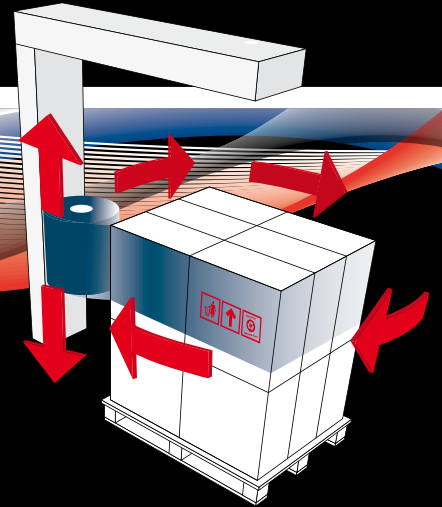

ROBOPAC
SISTEMI

ROBOPAC SISTEMI

ROBOPAC SISTEMI, established in 1985, is the world leader in the production of systems of fully automatic stretch film wrapping machines for palletized loads. The Company stands out for its great capacity to provide customized and innovative solutions in both performance and reliability. Three technologies have been developed for load packaging: rotating arms, turntables, and rotating rings, in addition to horizontal wrappers for elongated products and packaging systems for the wood industry. Thanks to a worldwide capillary distribution network, and to the spare parts servicing centers present in our foreign affiliates, ROBOPAC SISTEMI ensures quick, decisive after sales service support.

AETNA GROUP

AETNA GROUP produces and sells on a worldwide basis stretch film wrapping machinery, bundlers, shrink film wrappers, cartoning and taping machines. The Group counts 460 employees of which 80 engaged in the After Sales Department. 94,000 machines sold and installed worldwide with yearly sales of over 124 million dollars. Four production plants, three of which are in Italy, one in the Republic of San Marino, a joint venture in India, ROBOPAC PERKS, a network of over 460 Agents and Distribution and 5 foreign affiliates located in France, Great Britain, Germany, United States and the new AETNA GROUP VOSTOK in Moscow.

ROBOPAC SISTEMI pursues the Quality policy with commitment and by following this direction in 2003 it has received from TÜV SÜD ITALIA the acknowledgement consequently renewed in 2006 for the adequateness of its organization to the UNI EN ISO 9001:2000.

HELIX

A complete range of automatic machines with rotating arms for stretch wrapping palletized loads, and is particularly suited for high production output. Thanks to the rotating arm technology, the pallet remains fixed during the wrapping process to eliminate any possibility of de-stabilizing the load, at any wrapping speed.





The machines of the Helix series represent the ideal solution for wrapping light, easily deformable, unstable loads and find vast applications in various market segments. The design of the Helix series incorporates several models to accommodate a wide selection of pallet sizes and throughput speeds:

- HELIX HS 30 65 Loads/h
- HELIX HS 35 70 Loads/h
- HELIX HS 40 85 Loads/h
- HELIX HS 40/2 170 Loads/h

ROBOPAC SISTEMI also provides of a vast choice of pallet handling systems: roller conveyors, chain conveyors, deviators, track conveyment systems, stackers and other devices for the complete packaging control from end of line palletization to warehouse.

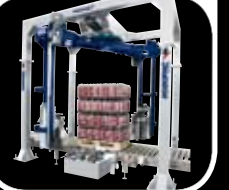

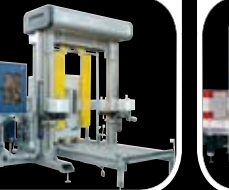
ROBOPAC SISTEMI's production range in packaging with stretch film is based on the following types of machines:

ROTOPLAT 	HELIX 	GENESIS 	ROBOHOOD 	ROBOSAND 	SPIROR 
Automatic turntable wrapping machine	Automatic rotating arm stretch wrapping machines	Vertical rotating ring wrapping machines	Automatic stretch hood machines	Automatic band wrapping machines	Horizontal rotating ring wrapping machines

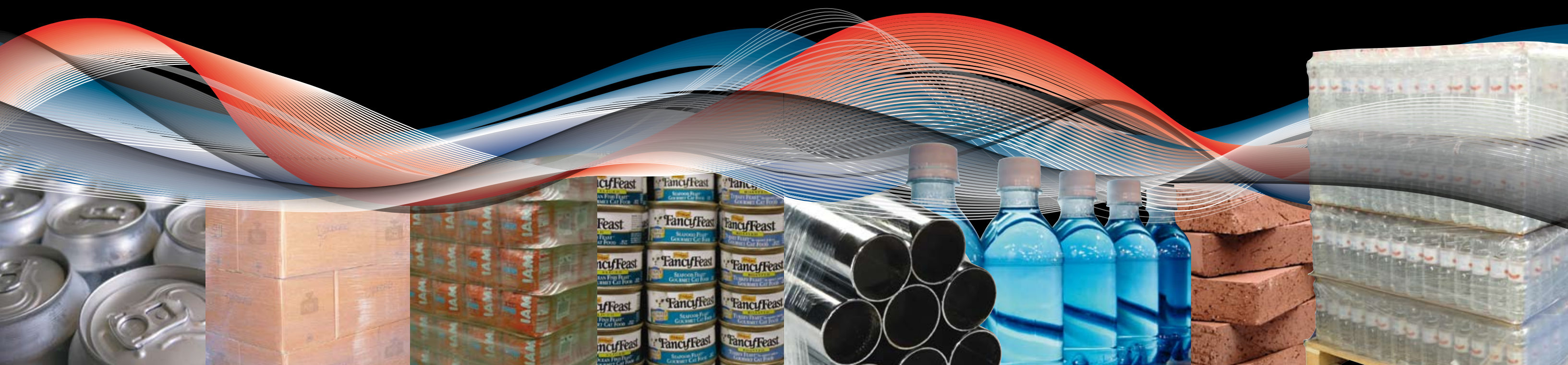

HELIX HS30/HS35



HELIX HS40



HELIX HS40/2

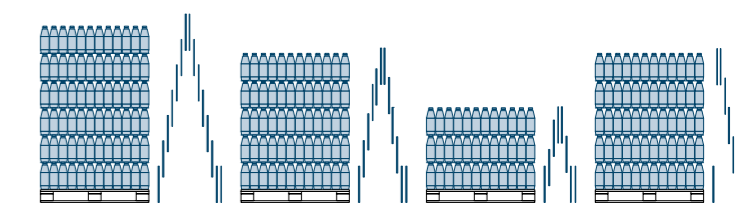

giri/wraps	16	13	9	9
sec/pallet	25	24	20.5	20.5
pallet/h	144	150	150	175



ROTATION UNIT

| A.

Toothed wheel kinematics on heavy duty bearing with pinion transmission. Robust and tubular frame that ensures maximum operating reliability during heaviest work conditions. Rotation arm control by frequency changer for operation at maximum rotation speed safeguarding duration and integrity of the transmission.



CARRIAGE LIFTING

| B.

Double chain system for maximum safety in any work condition. Up/down carriage speed controlled by frequency changer and continuously adjustable from control panel with possibility of changing the film overlapping band either upward or downward.



CLAMP AND CUT

| C.

Spring clamp (Robopac patent) with pulse hot wire film cut and film tail pallet welding device. Scissor clamp with hot wire film cut; optional welding unit available. Ring clamp with hot wire film cut complete with welding unit.



ROPING DEVICE

| D.

Device that reduces the film strip into a "rope" to ensure more efficient load stabilization. Film is grouped low/high in the single movement version while it is grouped at the centre in the dual cylinder version.



TOP PLATEN UNIT

| E.

Pneumatically driven device used with top cover systems (Top Inside/Top Outside) or for especially unstable loads. Also available in the pneumatic drive version or mechanical drive version with pantograph system.



TOP SHEET COVER

| F.

Top sheet load covering devices. In the TOP INSIDE version, top sheet withdrawal, cut and positioning occur inside the machine. TOP OUTSIDE version available. In this version, film roll positioning outside the machine facilitates its replacement.

ROBOPAC PRE-STRETCH UNITS

TECHNOLOGY AND INNOVATION FOR HIGH PERFORMANCES

The roll carriage units that equip the wrapping machines of the Helix series, thanks to the large diameter pre-stretch rollers and excellent grip of the materials used for the coatings of the same, reach the maximum film elongation values ensuring:

- optimum load stabilization
- low film consumption
- reduced environmental impact

Electromagnetic brake carriage on return roller with film elongation values adjustable from control panel available only on models HELIX HS 30, HELIX HS 35 and HELIX HS 40.

Powered rollers pre-stretch carriage with fixed ratios available on HELIX HS 30 and HELIX HS 35. Maximum pre-stretch value: 340%; other values available: 80% - 150% - 190% - 225%. Film deposit force onto the load controlled by electronic device.

Powered rollers pre-stretch carriage with two independent motors and pre-stretch ratio adjustable from 80% to 400% from control panel available on HELIX HS 30 and HELIX HS 35. In option, pre-stretch ratio display on control panel. Film deposit force onto the load adjustable from panel and controlled by electronic device.

Powered rollers pre-stretch carriage with fixed ratios available HELIX HS 40 and HELIX HS 40/2. Maximum pre-stretch value: 270%. Other values available: 65%, 150%, 185%, 215%. Film deposit force onto the load controlled by pneumatically operated dancing roller compensation device.

Powered rollers pre-stretch carriage with variable ratios by motorized gear box from 65% to 400% available on HELIX HS 40 and HELIX HS 40/2. Film deposit force onto the load controlled by pneumatically operated dancing roller compensation device

The film deposit force control onto the load occurs by:

- **pneumatically operated dancing roller compensation system.** Patented electronic devices continuously adjustable from control panel. Such solutions make wrapping possible without deforming even the particularly light, fragile, soft loads. All carriages can be dimensioned for using various film types:
- **roll band 30" wide allows significant production output capacity**
- **jumbo roll (outer diameter 15", weight 88lbs) 20" band reduces machine stops for roll change.**

Weaved or stretch net rolls can be used for products that require aeration.

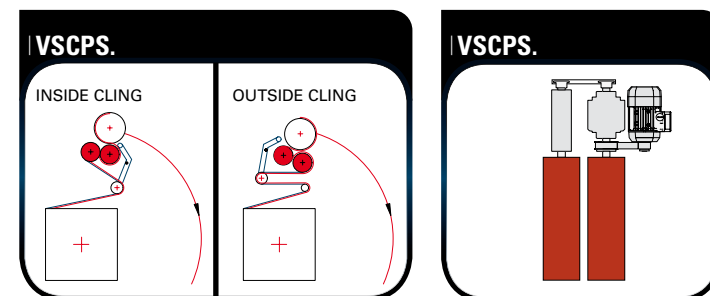
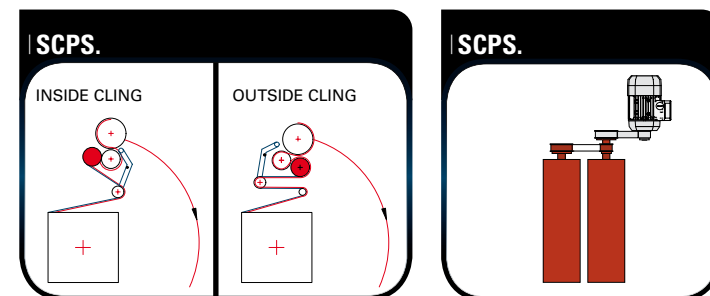
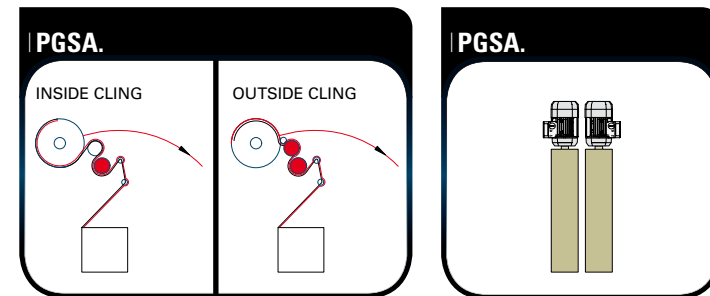
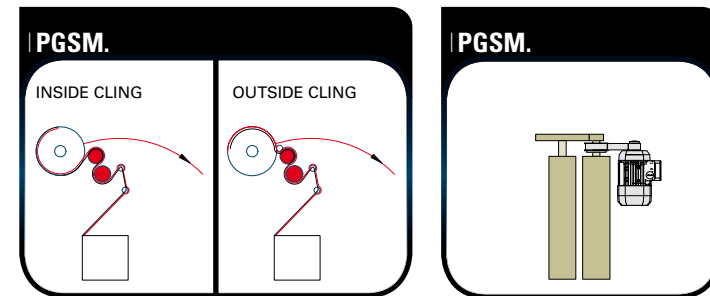
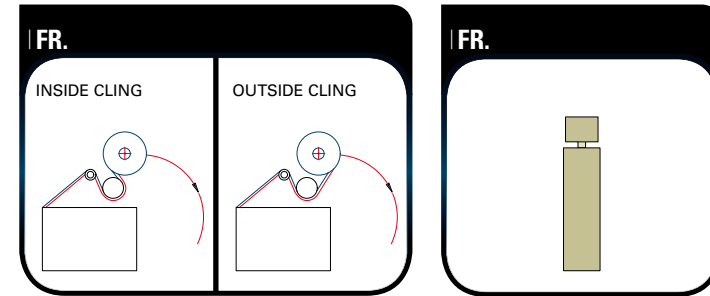

TECHNICAL FEATURES

MACHINES		HS30	HS30 T.I.	HS35	HS35 T.I.	HS40	HS40 T.I.	HS40 T.O.	HS40/2	HS40/2 T.O.
A	inches	79	79	79	79	85	85	83	83	83
B	inches	79	102	79	102	85	119	83	83	83
C	inches	157	181	157	181	169	203	165	165	165
D	inches	315	315	315	315	315	315	315	300	300
E	inches	80	80	80	80	80	80	80	118	118
F	inches	142	142	142	142	142	142	142	61	61
G	inches	80	80	80	80	80	80	80	118	118
H	inches	165	165	165	165	163	171	163	146	146
P	inches	79	79	79	79	79	79	79	79	79
T	inches	20	20	20	20	20	20	20	20	20
Pallet dimensions (*)		47x47	47x47	47x47	47x47	47x47	47x47	31x47	31x47	31x47
Arm speed	Rpm	22	22	30	30	36	36	36	38	38
Max. output capacity	Pallet/h	65	52	70	55	85	64	85	170	170
Standard power supply	V/Hz	400/50	400/50	400/50	400/50	400/50	400/50	400/50	400/50	400/50
Power installed	Kw	3.0	3.6	3.6	4.5	6.5	7.0	8.4	13.0	14.9
Air pressure	Bar	6±1	6±1	6±1	6±1	6±1	6±1	6±1	6±1	6±1
Air consumption	NI/min	350	350	350	350	350	350	350	700	700

(*) POSSIBILITY OF STRETCH WRAPPING HALF AND QUARTER PALLET NOT POSSIBLE WITH XL AND XL T.I. / T.I. Top Inside / T.O. Top Outside

HS30 - HS35
HS30 T.I. - HS35 T.I. - HS40 T.I.

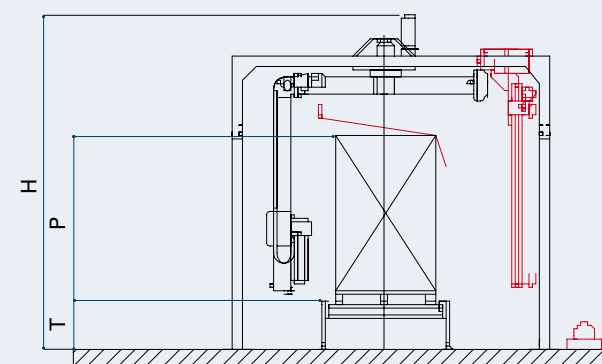
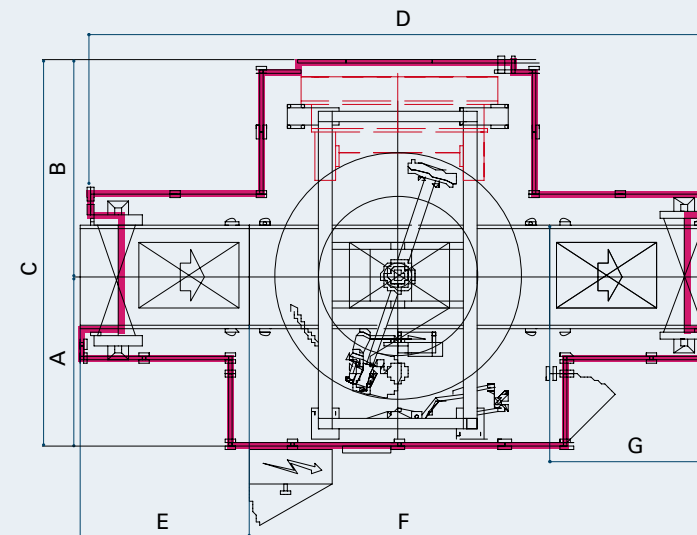

HS40 - HS40/2
HS40 T.O. - HS40/2 T.O.

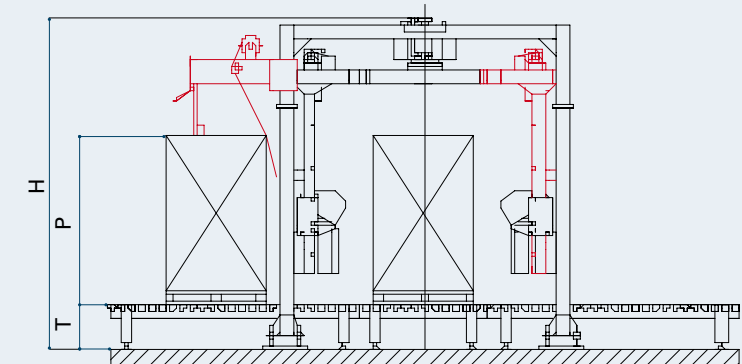
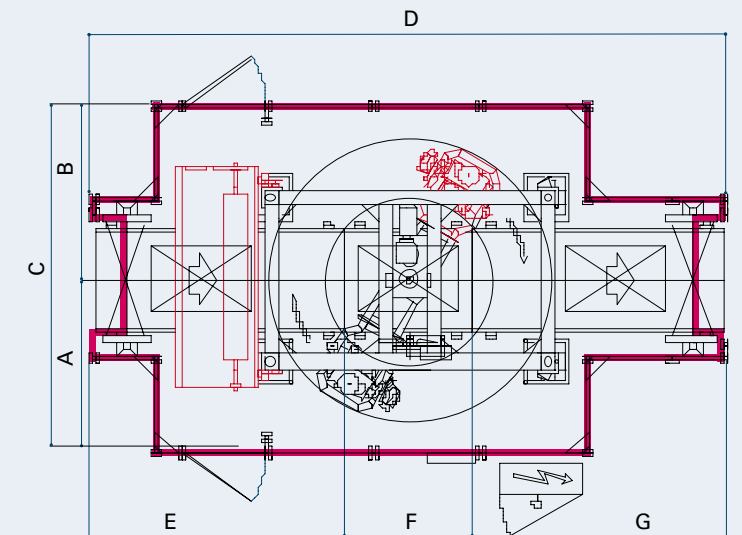

PERIMETRAL GUARDS ACCORDING TO CE WITH SAFETY PHOTOCELLS BARRIERS.
TECHNICAL SPECIFICATIONS MAY VARY WITHOUT PRIOR NOTICE.

We pack your business!
www.aetnagroup.com

AETNA GROUP U.S.A. Inc.

2475B Satellite Blvd. - Duluth - GA 30096-5805 - USA
phone (+1) 678 473 7896 - toll free (866) 713 7286 - fax (+1) 678 473 1025
aetnagroup@aetnagroupusa.com

ROBOPAC SA

Strada Rovereta, 27 - 47891 Falciano - Repubblica di San Marino
tel. (+378) 0549 910511 - fax (+378) 0549 908549/905946
ropobac@aetnagroup.com

AETNA GROUP SPA - ROBOPAC SISTEMI DIVISION

S.S. Marecchia, 59 - 47827 Villa Verucchio - Rimini
tel. (+39) 0541 673411 - fax (+39) 0541 679576
ropobacsistemi@aetnagroup.com

AETNA GROUP SPA - DIMAC DIVISION

Via Rinascita, 25 - 40064 Ozzano Emilia - Bologna
tel. (+39) 051 791611 - fax (+39) 051 6511013
dimac@aetnagroup.com

Via Villanova, 305 - 61010 Pietracuta di San Leo - Pesaro Urbino
tel. (+39) 0541 671131 - fax (+39) 0541 679576
pentatec@aetnagroup.com

AETNA GROUP UK LTD

Packaging Heights

Highfield Parc - Oakley - Bedford MK43 7TA - England
tel. (+44) 0 1234 825050 - fax (+44) 0 1234 827070
sales@aetna.co.uk

AETNA GROUP FRANCE S.a.r.l.

4, Avenue de l'Europe - 69150 Décines - France
tél. (+33) 04 72 14 54 01 - télécopie (+33) 04 72 14 54 19
commercial@aetnafr.aetnagroup.com

AETNA GROUP DEUTSCHLAND GmbH

Liebigstr. 6 - 71229 Leonberg - Höfingen - Germany
tel. (+49) 0 7152 33 111 30 - fax (+49) 0 7152 33 111 40
info@aetna-deutschland.de

ROBOPAC PERKS MACHINERY (I) PVT. LTD.

Khyati Industrial Estate, Plot B/7 - unit No. 115/116 - Laxmi Nagar
Goregaon (W) - Mumbai - 400 900 - India
tel. (+91) 022 878 2281 - fax (+91) 022 874 6173
perkengineering@vsnl.com

AETNAGROUP
USA 