



67-02-7 Effective: November 26, 2007

MACHINE SPECIFICATION

BEL 150 Semi-Automatic Top and Bottom Case Tape Sealer

The BEL 150 accepts uniform case sizes with the top flaps pre-folded by an operator before top and bottom tape sealing with either 2" or 3" wide tape. Belcor's *Uni-Drive* conveyor, with a single motor driving both side-belts synchronized, holds cases securely and keeps them square. The power required is 120V single-phase for the conveyor drive and it connects to an electrical outlet by a conventional cord and plug.

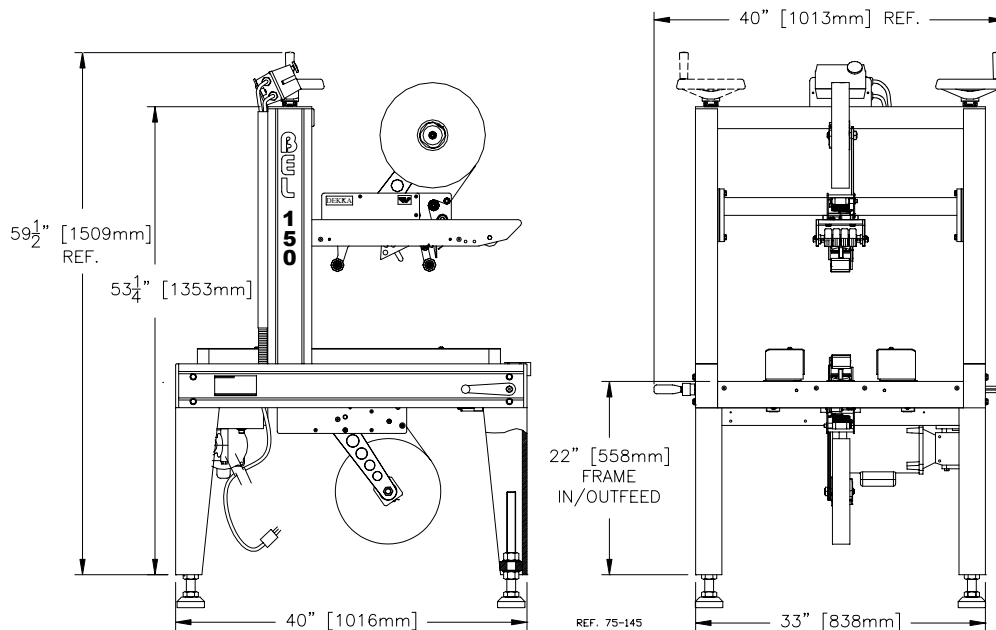

Standard Specifications:

		<u>Length</u>	<u>Width</u>	<u>Height</u>
Case Size Range	Minimum	8" / 203mm	5.5" / 140mm	4" / 102mm
	Maximum	[no limit]	17.38" / 440mm	21" / 533mm
Machine Dimensions		40" / 101mm	33" / 838mm	53.25" / 1353mm
In/Outfeed Height	Frame	22" / 558mm		
With adjustable leg extensions [foot pad]	Minimum	23.5" / 597mm		
	Maximum	32" / 813mm		
Speed		Up to 30 cases / min.		
Shipping Weight	Approx.	480 lbs. / 218 kg.		

For further detail see Layout Drawing 75-145

Construction:

Heavy-duty corrosion resistant paint-free frame made of high tensile anodized aluminum 'C-Beam' extrusions. All fasteners are stainless steel S.A.E.

Tape Heads:

Standard DEKKA Model 22, 2" tape heads with quick loading feature and center-pull tape guide system. Optional DEKKA 23, 3" width heads are available at extra cost.

Electrical Specifications:

120 VAC, 10A., 60 cycle, 1-phase NEMA 12, with a magnetic motor starter switch.

Drive System:

Uni-Drive synchronized side belt conveyor system powered by 1/2 H.P. TEFC motor and 3/4 H.P. rated gear reducer.

Drive Belts:

3" Leder brand rough top continuous loop with finger splice joint, and V-rib backing.

Safety Provisions:

Conveyor drive and belt pulleys are fully guarded. Magnetic motor starter switch prevents accidental restarts after a power interruption. Potential hazards are warned with labels to ANSI standards.

Nameplates / Identification:

The machine Model Number and Serial Number appear on a nameplate and the serial number is stamped onto the machine frame.

Documentation:

- Operation & Service Manual - providing set up, operating and troubleshooting information
- Technical Reference – spare parts kits, assembly and parts reference drawings, electrical schematic diagram.

Warranty:

On Machinery and Parts manufactured by the Company, Wexxar Packaging Inc. (the "Company") warrants to the original purchaser ("Buyer") of the product described above (the "Product") that:

- (a) all non-moving, structural components of the Product (excluding hot melt systems and tapeheads) in all material respects, will be free of defects due to imperfect material or workmanship for a period of One (1) year from the date of invoice;
- (b) all powered mechanical parts of the Product, in all material respects, will be free of defects due to imperfect material or workmanship for a period of at least one (1) year from the time of shipping from the Company's factory;

and following Company's acceptance of a warranty claim, upon the Buyer's delivery of the defective Product to the Company's factory, the Company will repair or replace it at the Company's option.

The warranties set out above do not extend or apply to:

- (a) the routine replacement of parts due to normal wear and tear arising from use; this warranty does not extend to parts which may presumably be expected to wear out during the warranty period;
- (b) damage attributable to accident, misuse, improper maintenance, power surge, improper connection to a power source, placement of Product in hostile environment, or alterations not authorized by the Company, negligence, or accident;
- (c) accessories, attachments, parts or instruments sold with or attached to the Product that do not bear the Company's trade mark ("Components");
- (d) any warranty claim not made in writing to the Company at its head office within the applicable warranty period and within ten (10) days of Product failure.
- (e) This warranty does not cover shipping costs;

This warranty shall be the only warranty in effect and is made exclusive of all other warranties and guaranties written or oral, expressed or implied.

COMPONENTS

On request and to the fullest possible extent, the Company will assign to the Buyer any interest it has in Component suppliers' warranteis for separately manufactured parts and accessories which form; are attached to; or constitute part of the Product. This includes tape heads.

CANCELLATION

Orders cannot be cancelled without consent of an authorized employee of the Company and in such cases the customer will fully indemnify the Company, unless agreed otherwise in writing by the Company.

TITLE

The title and right of possession of the goods quoted hereto shall remain with the Company and such goods shall remain Company property until all payments have been made in full. The purchaser agrees to do all that is required to maintain such right and title with the Company.

PRICE

All prices quoted are F.O.B. Company warehouse unless otherwise specified. Prices quoted are subject to change and do not include taxes or duties, if applicable.