

## Uniform Semi-Automatic, Top and Bottom Case Sealer

# STA-52

S E R I E S

- Most cost effective system
- Simple, reliable side drive belt system
- 2" or 3" Taping
- Fast, easy setup and adjustments
- Top mast can be raised to accommodate taller cartons
- Can use a 3 flaps closer and other options
- Heavy duty casters are standard
- Motor overload protection
- Top flap compression rollers are standard
- Heavy duty frame
- Heavy duty transmission system



### APPLICATION

The STA-52 is a modular designed uniform carton sealing machine. After the operator closes the top flaps and feeds the carton into the machine, the top and bottom flaps are simultaneously taped. There is no limit on the carton length and the machine can handle a maximum width of 20.47" and a maximum height of 23.50". Its versatility rates as one of the best in the market.

Dual side belt drives make the STA-52 well suited for a wide variety of carton sizes and shapes. Along with the 90FPM belt speed it's one of the most cost-effective case sealers in the industry.

### EXCLUSIVE STA TAPE HEAD

The patented STA taping head design is uniquely engineered to maintain consistent pressure to the tape to ensure the most secure, reliable seal possible. Our new line of interchangeable pressure sensitive taping heads are offered in a variety of tab lengths and tape widths to fit your application.

For the best results, rely on STA Proven Performance acrylic tapes, for use with your high-throughput sealing machines. Together, you have the most reliable single source tape sealing system.

# STA-52

## SERIES

### Uniform Semi Automatic, Top and Bottom Case Sealer

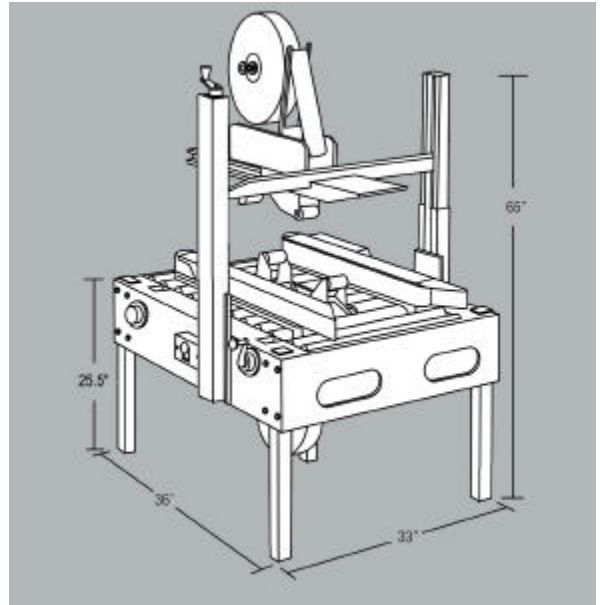

#### TAPE

- SUPREME
- SILENT SUPREME™
- EASY RELEASE™
- NATURAL RUBBER
- PRINTED
- COLORS
- RETAIL ROLL
- LABEL PROTECTION
- STATIONERY
- UPVC
- MASKING
- STRAPPING
- FILAMENT
- WATER ACTIVATED REINFORCED AND GUMMED PAPER

#### DISPENSERS

- HAND DISPENSERS
- NOISE REDUCING DISPENSERS
- BENCH DISPENSERS

#### MACHINES

- UNIFORM SEMI-AUTOMATIC CASE SEALERS
- UNIFORM AUTOMATIC CASE SEALERS
- RANDOM SEMI-AUTOMATIC CASE SEALERS
- RANDOM AUTOMATIC CASE SEALERS
- PACKING STATIONS
- CASE ERECTORS
- INTERCHANGEABLE TAPE HEADS

#### ACCESSORIES

- PACKING TABLES & STATIONS
- CASTERS
- THREE FLAPS CLOSERS
- BOX BLOCKING SYSTEM

#### SPECIFICATIONS

Model Number	Tape Width	Tab Length	Length Min. - Max.*	Width Min. - Max.*	Height Min. - Max.*
STA52	2"	2"	5.90" - Unlimited	3.94" - 20.47"	3.94" - 19.68" (+4)
STA5221	2"	1"	5.90" - Unlimited	3.94" - 20.47"	3.94" - 19.68" (+4)
STA5223	2"	3"	5.90" - Unlimited	3.94" - 20.47"	4.69" - 19.68" (+4)
STA5233	3"	3"	5.90" - Unlimited	4.94" - 20.47"	4.69" - 19.68" (+4)
STA5232	3"	2"	5.90" - Unlimited	4.94" - 20.47"	3.94" - 19.68" (+4)
STA67	2"	2"	6.00" - Unlimited	4.72" - 26.00"	4.00" - 26.00" (+4)
STA6723	2"	3"	6.00" - Unlimited	4.72" - 26.00"	4.69" - 26.00" (+4)
STA6733	3"	3"	6.00" - Unlimited	4.94" - 26.00"	4.69" - 26.00" (+4)
STA6732	3"	2"	6.00" - Unlimited	4.94" - 26.00"	4.00" - 26.00" (+4)
STA82	2"	2"	6.00" - Unlimited	4.72" - 32.00"	4.00" - 32.00" (+4)
STA8223	2"	3"	6.00" - Unlimited	4.72" - 32.00"	4.69" - 32.00" (+4)
STA8233	3"	3"	6.00" - Unlimited	4.94" - 32.00"	4.69" - 32.00" (+4)
STA8232	3"	2"	6.00" - Unlimited	4.94" - 32.00"	4.00" - 32.00" (+4)
STA52INOX	2"	2"	5.90" - Unlimited	3.94" - 20.47"	3.94" - 19.68" (+4)
STA52INOX23	2"	3"	5.90" - Unlimited	3.94" - 20.47"	4.69" - 19.68" (+4)
STA52INOX33	3"	3"	5.90" - Unlimited	4.94" - 20.47"	4.69" - 19.68" (+4)
STA52L21	2"	1"	5.90" - Unlimited	3.94" - 20.47"	2.36" - 18.50"

\*Recommended carton specifications may vary

**Power Requirements:** 110V / 60Hz / 1PH

**Tape Width:** 2-in., 3-in.

**Maximum Case Weight:** 95 lbs.

**Belt Speed:** 90 FPM

**Machine Dimensions:** 52: (LxWxH) 35-1/2" x 31-1/4" x 52" 67: 47-1/4" x 39-3/8" x 72" 82: 47-1/4" x 45-9/32" x 78"

**Shipping Dimensions:** 52: (LxWxH) 36" x 35" x 38" 67: 50" x 43" x 58" 82: 50" x 50" x 68-11/16"

**Machine Weight:** 182 lbs.

**Shipping Weight:** 210 lbs.

**Authorized STA Packaging Tapes Distributor:**

Specifications are subject to change without notice. Printed in the U.S.A. All trademarks and registered trademarks are property of Sekisui TA Industries, Inc.