

KRONES Cold-glue labellers
The classic labellers



Unrivalled quality

KRONES Cold-glue labellers

Cold-glue labellers from KRONES are characterised by the variability of their design in allowing modifications, the diversity of the possibilities for their use and high machine availability. Thanks to the many years of experience KRONES has in constructing rotary type machines and high-performance labelling stations, these machines have reached an unrivalled level of quality. They work in every respect with precision and reliability, are straightforward to operate and can be easily changed over to other sizes/shapes of container and label. They are furthermore impressive because of their stable value, and yet are easily adapted and retrofitted should the product range change or be modified.



Method of operation

The infeed starwheel transfers the containers to the revolving container table. They are firmly held and centred here between the container plates and centring bells. The rubber-coated glue pallets in each labelling station are given a very thin film of glue from a gluing roller made of hardened steel. The pallets pick up the labels from a magazine, apply a film of glue to the labels, and then transfer the labels to the gripper cylinder. The gripper cylinder places these labels with precision on the containers as they pass by on the container table. The labels are held in place on the containers while being smoothed out with brushes and sponged rollers. The labelled containers are collected by the discharge starwheel and transferred to the conveyor.



*KRONES Universella label
brushing-on station*

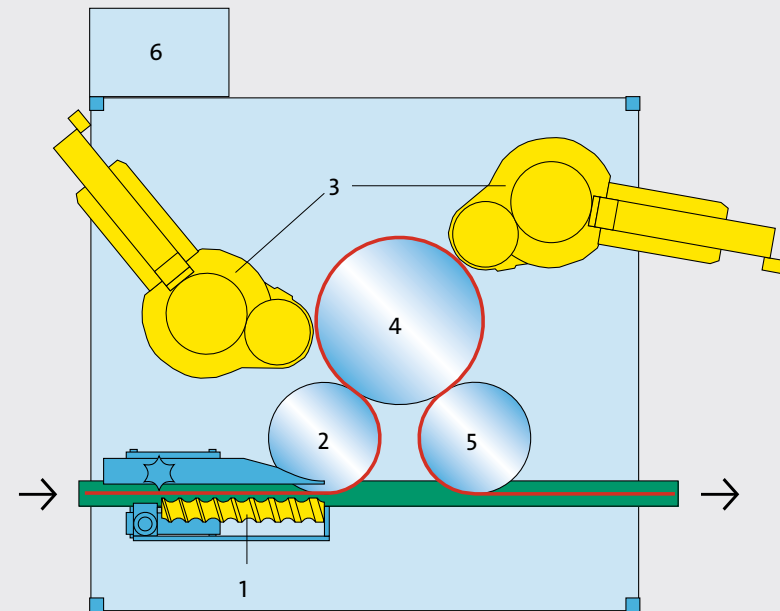

- 1 Infeed worm
- 2 Infeed starwheel
- 3 Labelling stations
- 4 Container table
- 5 Discharge starwheel
- 6 Control cabinet with operator terminal

Containers per hour (max.)

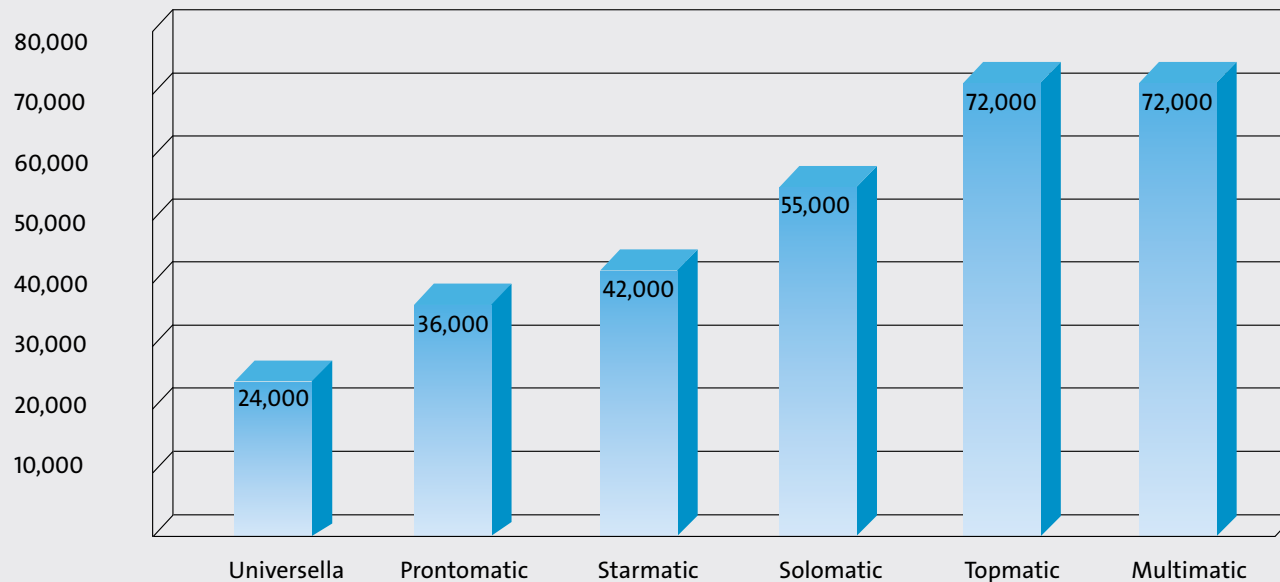

Design features

- Rotary type machines
- Supporting frame made from hot-galvanized steel, stainless steel cladding
- Adjustable lifting cam for lifting and lowering the centring bells
- Pneumatic glue pump, KRONES Unipump-H, with integrated thermostat-controlled heater
- Back-up switch at the container discharge
- Broken bottle detection system
- Central lubrication points
- Automatic oil-circulating lubrication for the container table and the labelling stations

Application

Labelling glass and plastic containers with pre-cut labels and foil

Output range

Machine performance from 6,000 to 72,000 containers per hour depending on the model

Cold-glue labelling station

KRONES Cold-glue labellers

- Synchronizing system: Pallet carousel and gripper cylinder turn in the same direction
- Pallet adjustment by cam roller running in the oil bath
- Gluing roller of hardened steel in combination with rubber-coated pallets
- No play in the suspension of glue roller and pallet shaft supports, and hence low wear
- Invariable adjustment in the setting for the glue film thickness on the glue roller, with fine thread and reference indicator
- Virtually no glue splashes in the machine thanks to the oscillating motion of the moving glue pallets; high standard of hygiene and low strain on the labels
- Hygienic design: Sloping bases
- Optional: Height-adjustable versions of the unit



KRONES Multimatic

KRONES Cold-glue labellers

- Container-table diameter: 2,400 mm
- Maximum machine output: 72,000 containers per hour
- Variant 1: Up to four labelling stations, each capable of attaching two or more labels
- Variant 2: Up to four labelling stations with motorised height adjustment, each capable of attaching one label
- Optional equipment for disengaging any stations and units not required
- Automatic label-magazine loading AMB (optional)
- Optimum brushing-on section on the large container table

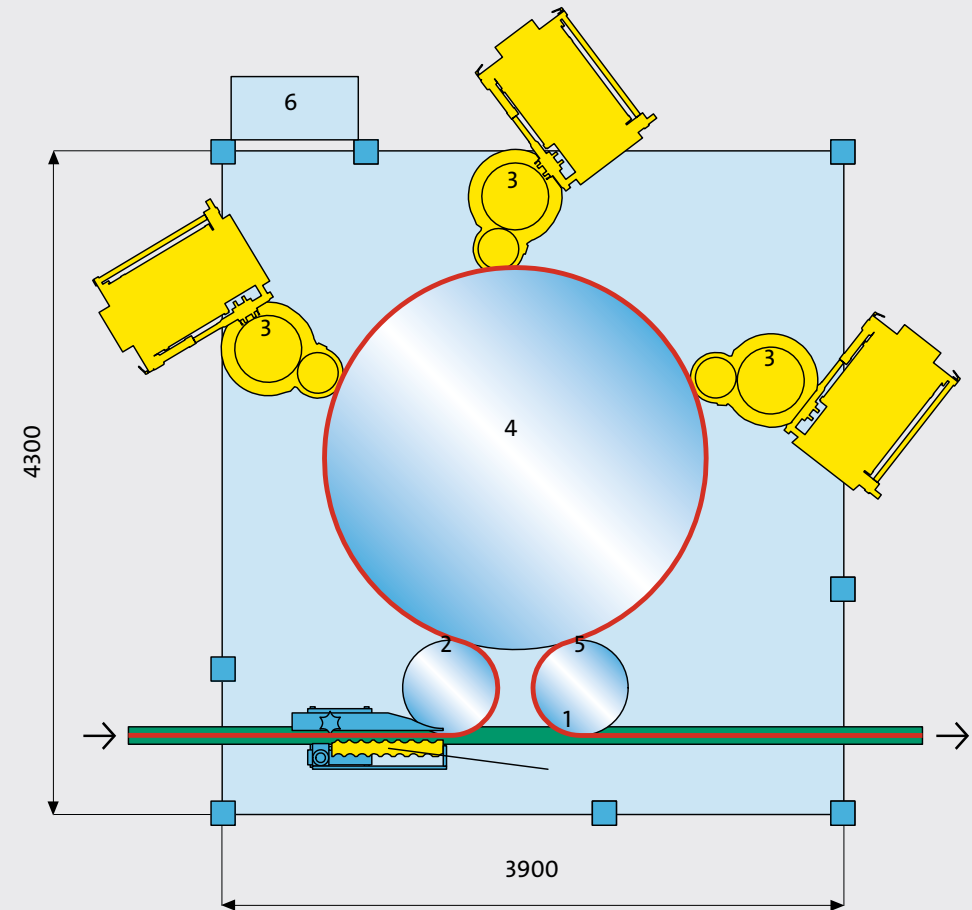

- 1 Infeed worm
- 2 Infeed starwheel
- 3 Labelling stations with AMB
- 4 Container table
- 5 Discharge starwheel
- 6 Control cabinet

KRONES Topmatic

KRONES Cold-glue labellers

- Container-table diameter: 1,800 mm
- Maximum machine output: 72,000 containers per hour
- Variant 1: Up to four labelling stations, each capable of attaching two or more labels
- Variant 2: Up to four labelling stations with motorised height adjustment, each capable of attaching one label
- Optional equipment for disengaging any stations and units not required
- Automatic label-magazine loading AMB (optional)
- Optimum brushing-on section on the large container table

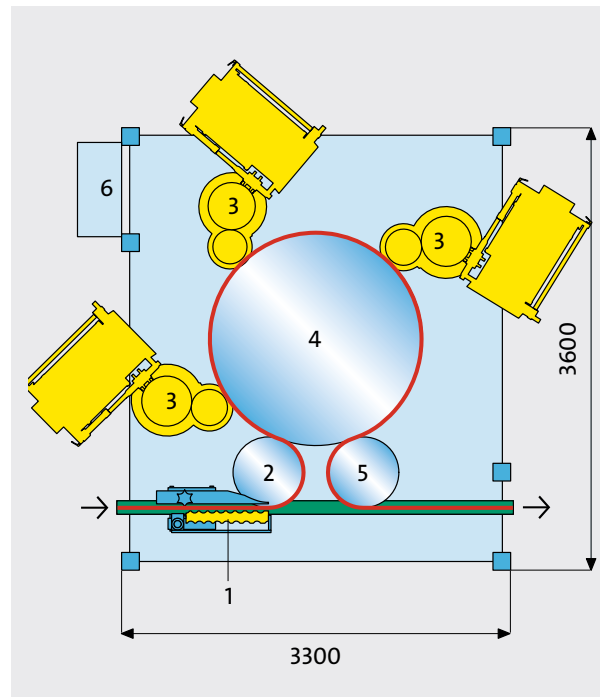

- | | |
|-------------------------------|-----------------------|
| 1 Infeed worm | 4 Container table |
| 2 Infeed starwheel | 5 Discharge starwheel |
| 3 Labelling stations with AMB | 6 Control cabinet |

KRONES Solomatic

KRONES Cold-glue labellers

- Container-table diameter: 1,200 mm
- Maximum machine output: 55,000 containers per hour
- Variant 1: Up to three labelling stations, each capable of attaching two or more labels
- Variant 2: Up to three labelling stations with motorised height adjustment, each capable of attaching one label
- Optional equipment for disengaging any stations and units not required

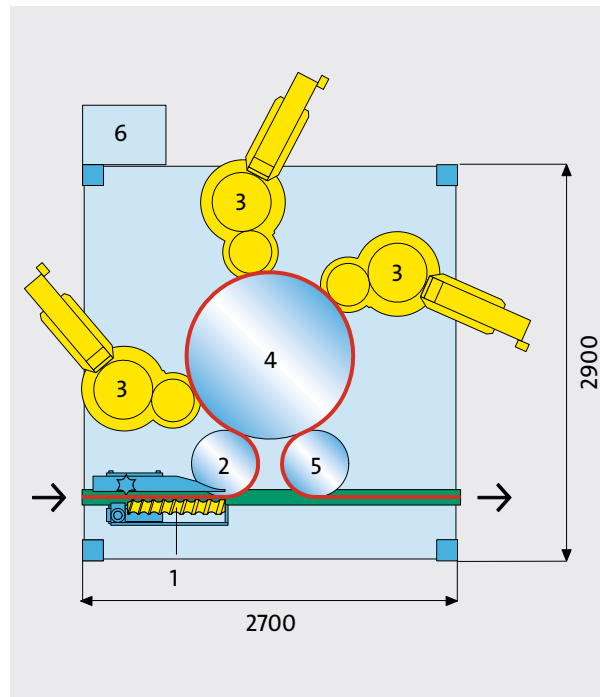

- | | |
|----------------------|-----------------------|
| 1 Infeed worm | 4 Container table |
| 2 Infeed starwheel | 5 Discharge starwheel |
| 3 Labelling stations | 6 Control cabinet |



KRONES Starmatic

KRONES Cold-glue labellers

- Container-table diameter: 960 mm
- Maximum machine output: 42,000 containers per hour
- One or two labelling stations, each capable of attaching two or more labels

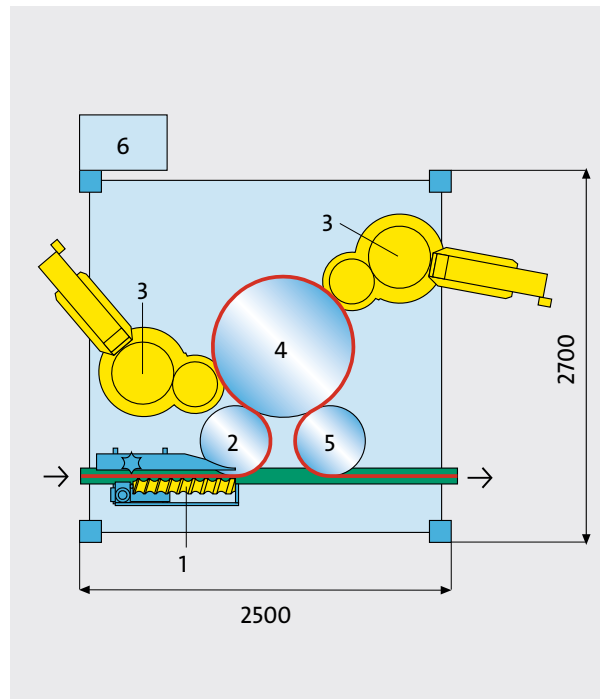

- | | |
|----------------------|-----------------------|
| 1 Infeed worm | 4 Container table |
| 2 Infeed starwheel | 5 Discharge starwheel |
| 3 Labelling stations | 6 Control cabinet |



KRONES Prontomatic

KRONES Cold-glue labellers

- Container-table diameter: 720 mm
- Maximum machine output: 36,000 containers per hour
- One or two labelling stations, each capable of attaching two or more labels

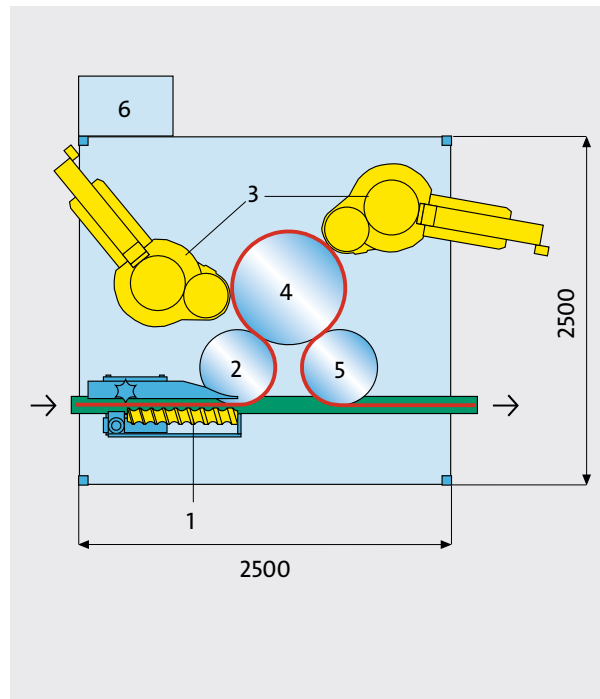

- | | |
|----------------------|-----------------------|
| 1 Infeed worm | 4 Container table |
| 2 Infeed starwheel | 5 Discharge starwheel |
| 3 Labelling stations | 6 Control cabinet |



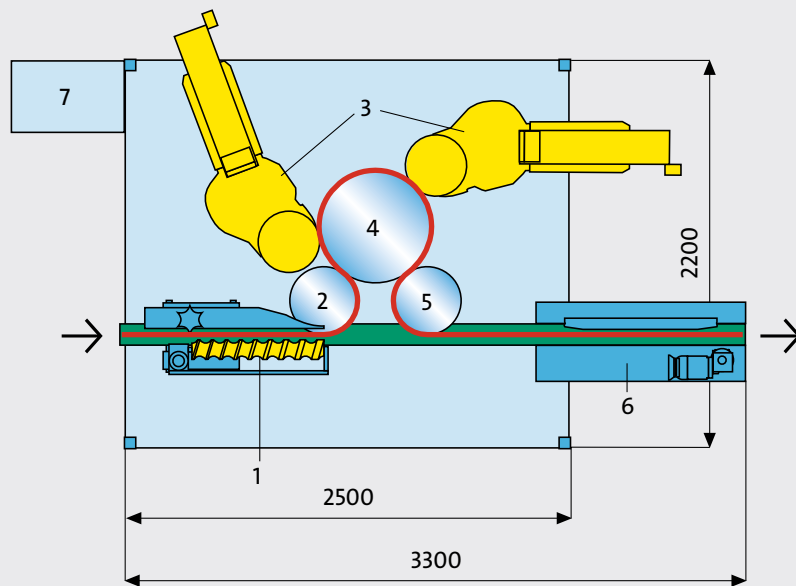

- Container-table diameter: 600 mm
 - Maximum machine output: 24,000 containers per hour
 - One or two labelling stations, each capable of attaching two or more labels
- | | |
|----------------------|-----------------------|
| 1 Infeed worm | 4 Container table |
| 2 Infeed starwheel | 5 Discharge starwheel |
| 3 Labelling stations | 6 Rolling-on unit |
| | 7 Control cabinet |



- Colour touch-screen
- Safe access to the user interface from separate transponders
- User-friendly menu guidance through the operating programme
- Easy-to-follow display of the current production data
- Malfunction shown in plain text with graphic display
- Text displayed in the selected language
- Interface to higher-level systems such as PDA (production data acquisition) or LMS (line management system)
- Remote maintenance possible



Change-over

When changing the format, the new type is first of all selected on the touch-screen. If new containers or labels are to be processed for the first time, all of the label parameters can be set and then saved from the menu by following the instructions. Each labelling station is adjustable along a horizontal cross slide, and the glue pallets can be replaced together with the associated shafts. Thanks to an adjustment system with indexed stops, container guide rails can also be quickly adjusted for the infeed worm. The Raptec guidance handling parts at the starwheels are colour-coded and their exchange is quick and straightforward. The height of machine head is adjusted by electrical means and automatically locked in place. Centring bells and container plates are equipped with single-hand fasteners making the exchange of these quick and straightforward.



Guide starwheel with quick-lock (photograph at the top)

Butterfly locking pin on the curved guide (photograph at the bottom)

Raptex handling parts at a labeller

The cold-glue labellers can be arranged in many different ways and can thus be adapted to an optimum to meet the particular spatial conditions. Besides the linear arrangement, parallel, and angular arrangements are also possible. The machines can also be blocked with a filler and a capper in a space-saving manner.

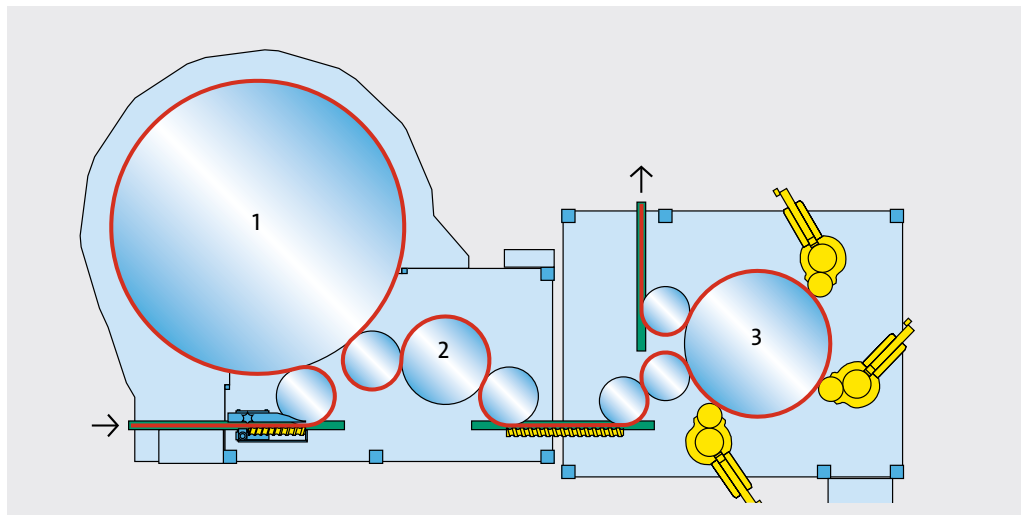
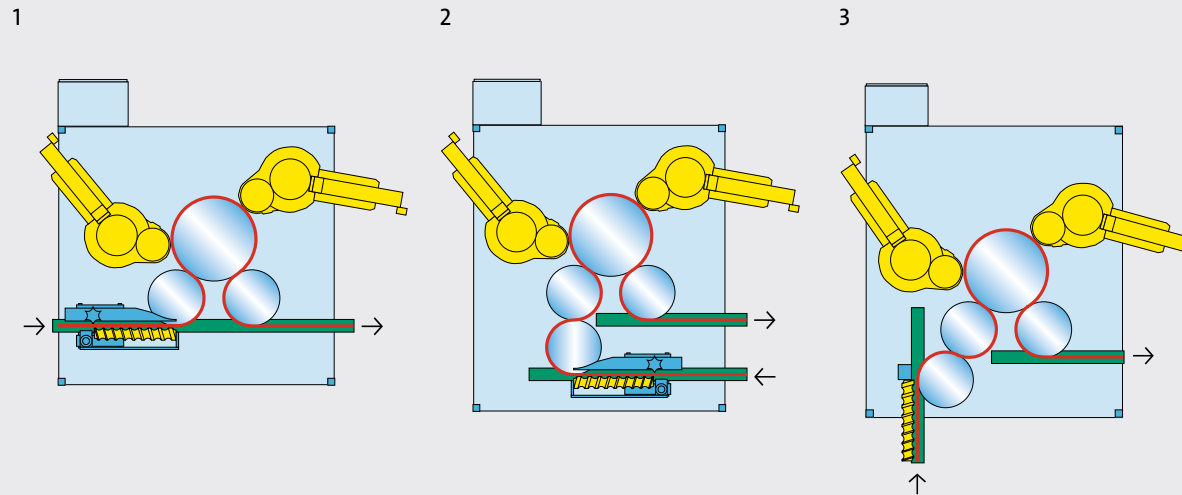

Block arrangement with filler (1),
capper (2) and cold-glue labeller (3)



Mechanical container orientation using side-spotting bars (Photograph on the left)



Orientation with camera detection (photograph in the centre)



Photoelectric orientation system (photograph on the right)

Mechanical container orientation

- Bottles with side-spotting bars or with handle: Mechanical orientation in a special infeed starwheel or at the container table
- Bottles with base-spotting bars: Mechanical orientation at the container table
- Bottles with swing stopper: Orientation in the infeed starwheel or on an orientation carousel

Orientation with camera detection

- Using several CCD cameras
- Recognition of text, emblems, spotting bars, swing stoppers, or the mould seam with glass bottles
- Signal to the central computer that the labelling position is correct
- Container rotation on servo-controlled container plates

Photoelectric container orientation

- Sensors focus on printed champagne caps or significant bumps on the bottle wall
- Signal to the central computer that the labelling position is correct
- Container rotation on servo-controlled container plates

Additional equipment

KRONES Cold-glue labellers

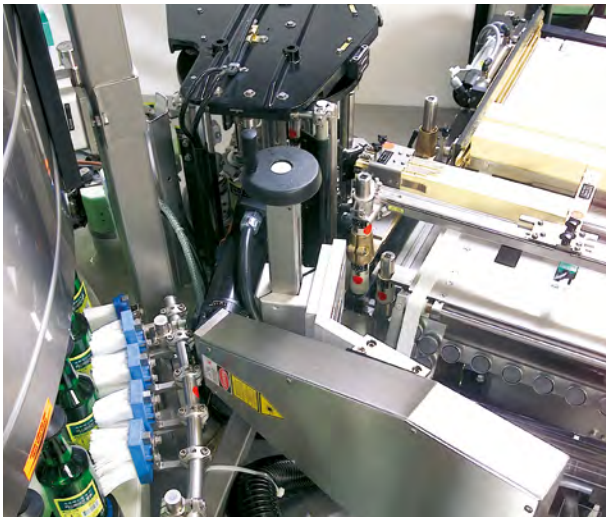

Coding/dating

- Printing of best before dates, inspection or code number, price or contents, on the front of the label, on the container wall, or on the cap
- Use of an ink-jet or laser printer
- Different fonts printed almost anywhere on the label or the container
- Coding/dating possible in all output ranges

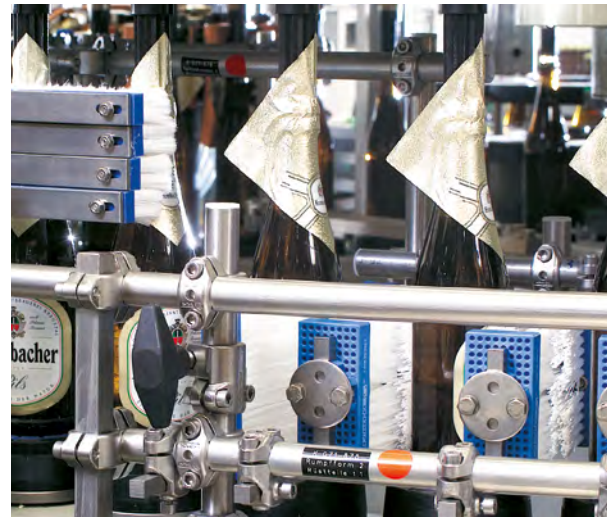

Foiling

- Round and pointed neck foil or neck foils attached using additional equipment
- Precision in centring the foil above the body label
- Gentle brushing-on in the neck and cap area
- For pointed neck foils, points folded over by rolling followed by driven brushing in the discharge star-wheel



Laser date coding at the container table (photograph on the left)

Pointed neck foil application with brushing-on station (photograph in the centre)

Tax strips attached by Taxomat, an auxiliary unit (photograph on the right)

Attaching tax strips

- I or L-shaped tax strips or tamper-evident strips attached at the cold-glue labelling station.
- L or U-shaped tamper-evident strips attached by Taxomat, the auxiliary unit from KRONES (basic machine must already be prepared for expansion)



KRONES Garantomat

- Attach a shrink sleeve as the tamper-evident seal
- Additional labelling station above the infeed or discharge of the modular labeller
- Unwind the sleeving and cut the shrink sleeve to length in the labelling station

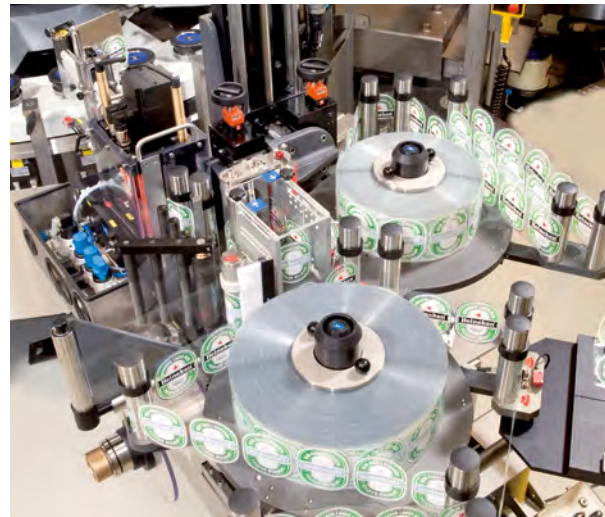

Labelling station for self-adhesive labels

- Installation of an Autocol dispensing unit for self-adhesive labels is possible
- Precise positioning of additional labels, e. g. tamper-evident seals, lid labels, campaign stickers.

Garantomat for attaching a shrink sleeve as a tamper-evident seal (photograph on the left)

Autocol dispensing unit for self-adhesive labels (photograph on the right)

More additional equipment

- Automatic label magazine loading, AMB, for up to 50,000 labels
- Multifunctional starwheels as infeed and discharge starwheels for handling different containers where the difference in diameter can be as much as 20 mm
- Central lubrication
- Additional handling parts for containers and labels
- Clearly arranged handling parts trolley
- Cabinet for storage of machine accessories
- Spare parts kits for 2,000 or 4,000 operating hours

System expansions

KRONES Checkmat – the versatile inspection unit

KRONES Cold-glue labellers

- Checks for presence of labels and their correctness
- Checks the position and angle of the label
- Checks printed-on data, like e. g. best before date and product code, for presence and correctness
- Recognises bar codes
- Checks the fill level and the container seal
- Discharges faulty containers using the retaining starwheel, clamping starwheel, or pusher



Your benefits

■ High labelling precision

The labels are attached to within a millimetre since the containers are held exactly in place in the machine carousel.

■ Low glue consumption

The combination of steel glue roller and rubber coated gluing pallets together with the well-designed mechanism for adjusting the thickness of the glue film keep the consumption of glue to a minimum.

■ High performance

The different versions of the cold-glue labellers cover all requirements for precision labelling in the range from low to maximum output.

■ Hygiene

Drain channels in the table top have been designed to remove all liquids.

■ User-friendliness

The cold-glue labellers are easily accessible and operation from the central touch-screen terminal is easy.

■ Time saving

Only short conversion times needed when changing containers and labels.

■ Stable value

The supporting frame of hot-galvanized steel together with stainless-steel cladding give the machines a long service life.

■ Flexibility for the future

The cold-glue labellers can still be retrofitted or modified, even after many years of service.



We do more.



KONPLAN



SYSKRON



KIC KRONES



KOSME



HST
KRONES GROUP



EVOGUARD

KRONES AG
Böhmerwaldstraße 5
93073 Neutraubling
Germany
Phone +49 9401 70-0
Fax +49 9401 70-2488
E-mail info@krones.com
Internet www.krones.com

KOSME s.r.l. unipersonale
Via dell' Artigianato, 5
46048 Roverbella (Mantova)
Italy
Phone +39 0376 751011
Fax +39 0376 751012
E-mail kosme@kosme.it
Internet www.kosme.com

EVOGUARD GMBH
Dr.-Hermann-Kronseder-Straße 1
93149 Nittenau
Germany
Phone +49 9436 307 700
Fax +49 9401 70 94 3700
E-mail info@evoguard.com
Internet www.evoguard.com

KIC KRONES
Internationale Cooperationsgesellschaft mbH
Böhmerwaldstraße 5
93073 Neutraubling
Germany
Phone +49 9401 70-3020
Fax +49 9401 70-3696
E-mail kic@kic-krones.com
Internet www.kic-krones.com

KONPLAN s.r.o.
Poděbradova 2842/1
301 00 Plzeň
Czech Republic
Phone +420 377 918 109
Fax +420 377 918 139
E-mail pilsen@konplan.cz
Internet www.konplan.cz

HST MASCHINENBAU GMBH
Gewerbstraße 19
23942 Dassow
Germany
Phone +49 38826 8878-0
Fax +49 38826 8878-1
E-mail info@hst-gmbh.com
Internet www.hst-maschinenbau-gmbh.de

SYSKRON GMBH
Oskar-von-Miller-Straße 6b
92442 Wackersdorf
Germany
Phone +49 9431 79857-0
Fax +49 9431 79857-11
E-mail info@syskron.com
Internet www.syskron.com



KRONES