



www.doyon.qc.ca • www.nu-vu.com

JA20

JET-AIR OVEN

The JA series from Doyon is known worldwide for its unique JET AIR SYSTEM. The air moves in one direction, stops then moves the other way resulting in a bidirectional and gentle velocity air flow for exceptional baking results. This system will help you bake faster and more evenly. Some pan rotation may be needed. The Jet Air fan system will save energy and labor costs.

The JA20 provides great flexibility in terms of range of products that can be baked or cooked. It features a programmable or manual one shot and constant pulse steam injection. To get the results you really want, we have added as standard a fan delay for those delicate products.



JA20

STANDARD FEATURES

OVEN

- Outstanding steam shot and pulse injection system
- Reversing fan system
- Two speeds fan
- Fan delay switch
- High production oven
- Manual mode and user friendly EBake programmable control up to 99 recipes
- Digital temperature control up to 500°F
- Digital reminder timer
- USB Port
- Brightly lit, compact space saving unit
- Full view heat reflective thermal glass doors
- Fully insulated, completely sealed
- Energy efficient electric or gas heating (baking temperature reached in 15 minutes)
- Magnetic latches
- Door switch cutoff for fan blower
- Stainless steel inside and outside
- 3/4 HP motor
- 2 year parts 1 year labor limited warranty

OPTIONS

- Perforated nickel plated pizza decks
- High temperature gasket for baking over 400°F (250°C)
- Water softener: PLF240
- Gas quick disconnect kit (4' (1120 mm) flexible hose, ball valve and securing device)

Experience our top-of-the-line ovens today!



5600 13th Street • Menominee, MI 49858 USA

Phone: 906-863-4401 E-mail: sales@nu-vu.com
Toll Free: 1-800-338-9886 www.doyon.qc.ca
Fax: 906-863-5889 www.nu-vu.com

OVERALL DIMENSIONS

JA20 53 1/4" W X 49 3/4" D X 73" H
 (1353 mm X 1264 mm X 1854 mm)
 JA20G 53 1/4" W X 53 5/8" D X 73" H
 (1353 mm X 1362 mm X 1854 mm)

OVEN INTERIOR DIMENSIONS

JA20 39" W X 30 3/4" D X 26 1/2" H
 (991 mm X 781 mm X 673 mm)
 JA20G 39" W X 29 3/4" D X 26 1/2" H
 (991 mm X 756 mm X 673 mm)

Shelf spacing 3 3/4" (95 mm)

ELECTRICAL SYSTEM

JA20

1 Phase:

208V - 130A - 27 kW - 60 Hz - 2 wires + Ground
 240V - 115A - 27 kW - 60 Hz - 2 wires + Ground

3 Phases:

208V - 75A - 27 kW - 60 Hz - 3 wires + Ground
 240V - 65A - 27 kW - 60 Hz - 3 wires + Ground
 480V - 35A - 27 kW - 50 Hz - 3 wires + Ground

Other voltages available

GAS SYSTEM

JA20 (Propane or natural)

BTU total: 170 000

1 phase:

120/208V - 11.5A - 2 kW - 60 Hz - 3 wires + Ground

Gas inlet : 1/2" NPT

Draft hood: 6" (152 mm)

Recommended gas pressure:

Propane gas : 11" W.C.

Natural gas : 7" W.C.

WATER INLET: 1/4" NPT

Minimum clearance from combustible material

1" (25 mm) side and back

4" (102 mm) on non combustible floor

12" (305 mm) top

FINISH: Stainless steel

SHIPPING WEIGHT

JA20 1435 lb (651 kg) approximately

JA20G 1600 lb (726 kg) approximately

CAPACITY

Standard sheet pans 18" X 26" (457 mm X 660 mm): 20 pans

Four-straped bread pans: 72 loaves

9" (230 mm) pies: 100 pies

JA20

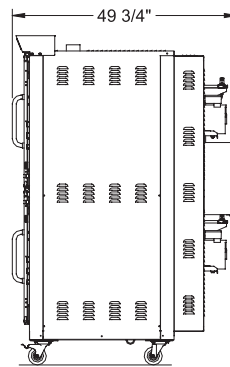
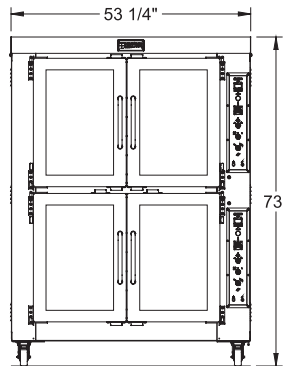

JA20G

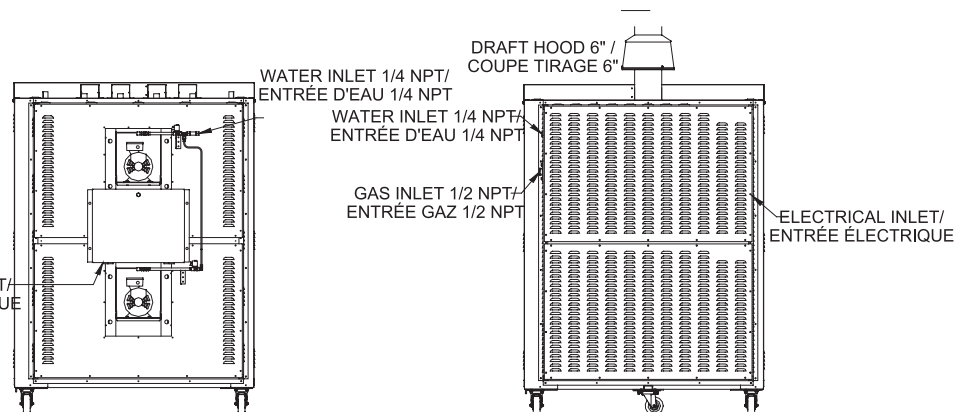
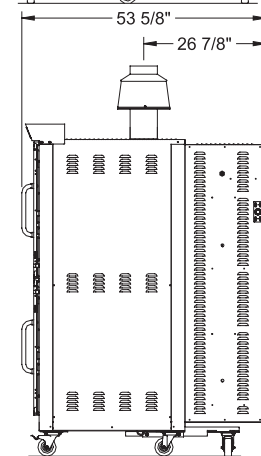
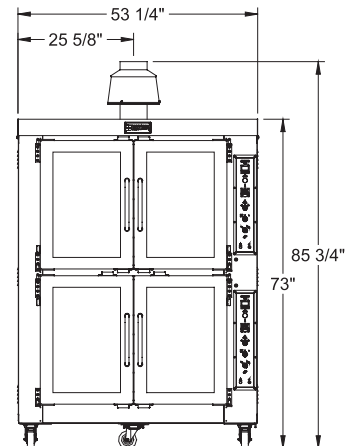

Electrical service connection and water inlet are located at the back of the unit.
 Specifications and design are subject to change without notice.



5600 13th Street • Menominee, MI 49858 USA
 Phone: 906-863-4401 E-mail: sales@nu-vu.com
 Toll Free: 1-800-338-9886 www.doyon.qc.ca
 Fax: 906-863-5889 www.nu-vu.com