

# MediSeal

Pharma Packaging Technology

02-2008

# MediSeal

Pharma Packaging Technology

## MediSeal – Synergies under one strong roof

MediSeal belongs to the KÖRBER MEDIPAK group of companies and – together with Swiss packaging specialists Rondo and Dividella – offers a full range of packaging systems. Benefit from the synergies of a strong group and take advantage of low-cost solutions for your production!



Cartoner	P1600 mm	P3000 mm	
<b>Advantages</b>	<b>120 pitch</b>	<b>180 pitch</b>	<b>120 pitch</b>
● Compact, modular construction	Carton length <b>65 – 150</b>	<b>65 – 200</b>	<b>65 – 150</b>
● Fast change-over	Carton width <b>35 – 90</b>	<b>50 – 150</b>	<b>35 – 85</b>
● Low format part and maintenance costs	Carton height <b>15 – 95</b>	<b>15 – 110</b>	<b>12 – 95</b>
● Noise emission < 70 dB			
	Output, cartons per minute <b>10 – 150</b>	<b>10 – 100</b>	<b>20 – 300</b>
Subject to technical modifications			



P1600 - P3000  
Technical data

P1600 - P3000

### Other KÖRBER MEDIPAK companies

#### MediSeal GmbH

Flurstraße 65  
D-33758 Schloss Holte  
Germany  
T +49 (0)52 07 888-0  
F +49 (0)52 07 888-299  
info@mediseal.de  
www.mediseal.de

#### Dividella AG

Werdenstrasse 76  
CH-9472 Grabs  
Switzerland  
T +41 (0)81 750 33 66  
F +41 (0)81 750 33 43  
info@dividella.ch  
www.dividella.com

#### Rondo AG

Gewerbestrasse 11  
CH-4123 Allschwil  
Switzerland  
T +41 (0)61 486 87 87  
F +41 (0)61 486 87 50  
sales@rondodruck.ch  
www.rondodruck.ch

#### Rondo obaly s.r.o.

Zemska 230  
CZ-33701 Ejovice  
Czech Republic  
T +420 371 515 515  
F +420 371 515 555  
sales@rondoobaly.cz  
www.rondoobaly.cz

#### Rondo-Pak Inc.

Valley Forge Corporate Center  
900 Madison Avenue  
Norristown, PA 19403, USA  
T +1 800 254 0731  
F +1 610 666 6116  
sales@rondo-pak.com  
www.rondo-pak.com

### KÖRBER MEDIPAK sales and service companies

**KÖRBER MEDIPAK NA INC.** 14501, 58th Street North • Clearwater, FL 33760 • USA  
T +1 727 538 46 44 • F +1 727 532 65 21 • info@kmedipak.com

**KÖRBER MEDIPAK France Sarl** Energy Park 4 • 155-159 rue du Dr. Bauer • 93400 Saint Ouen • France  
T +33 1 40 11 40 11 • F +33 1 40 11 51 10 • info@fr.koerber-medipak.com

**KÖRBER MEDIPAK UK & Rol** • Mountbatton House • Fairacres • Windsor • Berkshire SL4 4LE • UK  
T +44 (1753) 75 48 65 • info@uk.koerber-medipak.com

**KÖRBER MEDIPAK Asia-Pacific** c/o Hauni Singapore Pte. Ltd. • 6 Temasek Boulevard  
#30-04 Suntec City Tower 4 • Singapore 038986  
T +65 68 35 98 86 • F +65 68 36 92 96 • info@koerber-medipak.com

www.koerber-medipak.com



**MediSeal cartoners**  
Compact, modular and flexible.

# Flexibility

thanks to a wide range of formats



With the introduction of the P3000 in the late 'nineties, MediSeal achieved a milestone in the construction of flexible cartoning machines driven by servomotors. Together with the P1600, MediSeal now offers a high-performance family of horizontal cartoning machines. Whether in conjunction with a blister or sachet packaging machine or as a general-purpose cartoner for packaging vials, the modular construction of MediSeal cartoners offers practically unlimited versatility in the packaging of pharmaceutical products

## Flexible cartoners

- modular construction
- fast change-over
- for all pharmaceutical products

## Digital Servo Technology can handle an enormous range of formats

Dimensions in mm

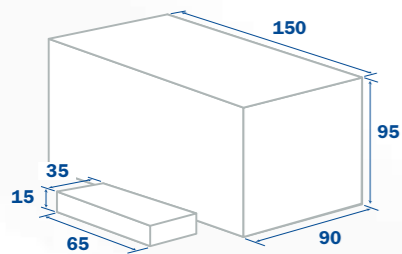

P1600 standard, 120 pitch

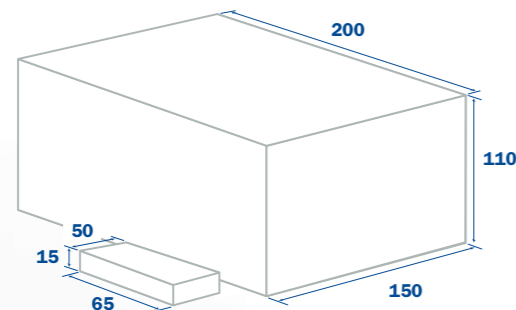

P1600 expanded, 180 pitch

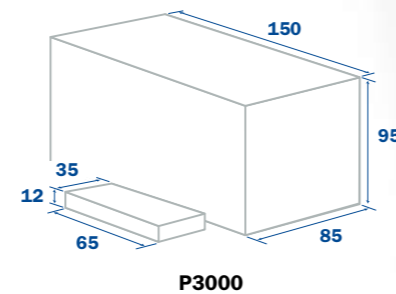

P3000

The P1600 and P3000 cartoners have been specially designed for packaging small and medium-sized lot sizes. The indexed method of operation means that the cartoners not only occupy a minimum footprint but also require few format parts, which can also be swapped out quickly and simply. Carton height adjustment is performed automatically via an actuator.

Whether it is a matter of the transfer systems, carton separation, leaflet feed, product insertion or closing systems – the P1600 and P3000 rely on the same proven assemblies and principles. The P3000 – the fastest in its class with an output of 300 folding cartons per minute – works in dual-cycle mode, whilst the P1600 is also able to handle very large cartons, with an output of 80 to 150 units per minute.



The P1600 and P3000 are designed as standard for installation of the latest generation of GUK 2000 folders. The folders are driven via their own servo shaft, so there is no need for adjustment via a mechanical clutch.

# Flexibility

thanks to digital servo drive technology

The integrated servomotor drive concept ensures a clear layout of all function units which is easy to monitor visually. Components which are moved mechanically have been largely eliminated by applying servo technology. Servicing and maintenance of the P1600 and P3000 is simple and costs considerably less than purely mechanical systems. A modem, fitted as standard, enables any machine malfunctions to be identified and rectified quickly by remote access.

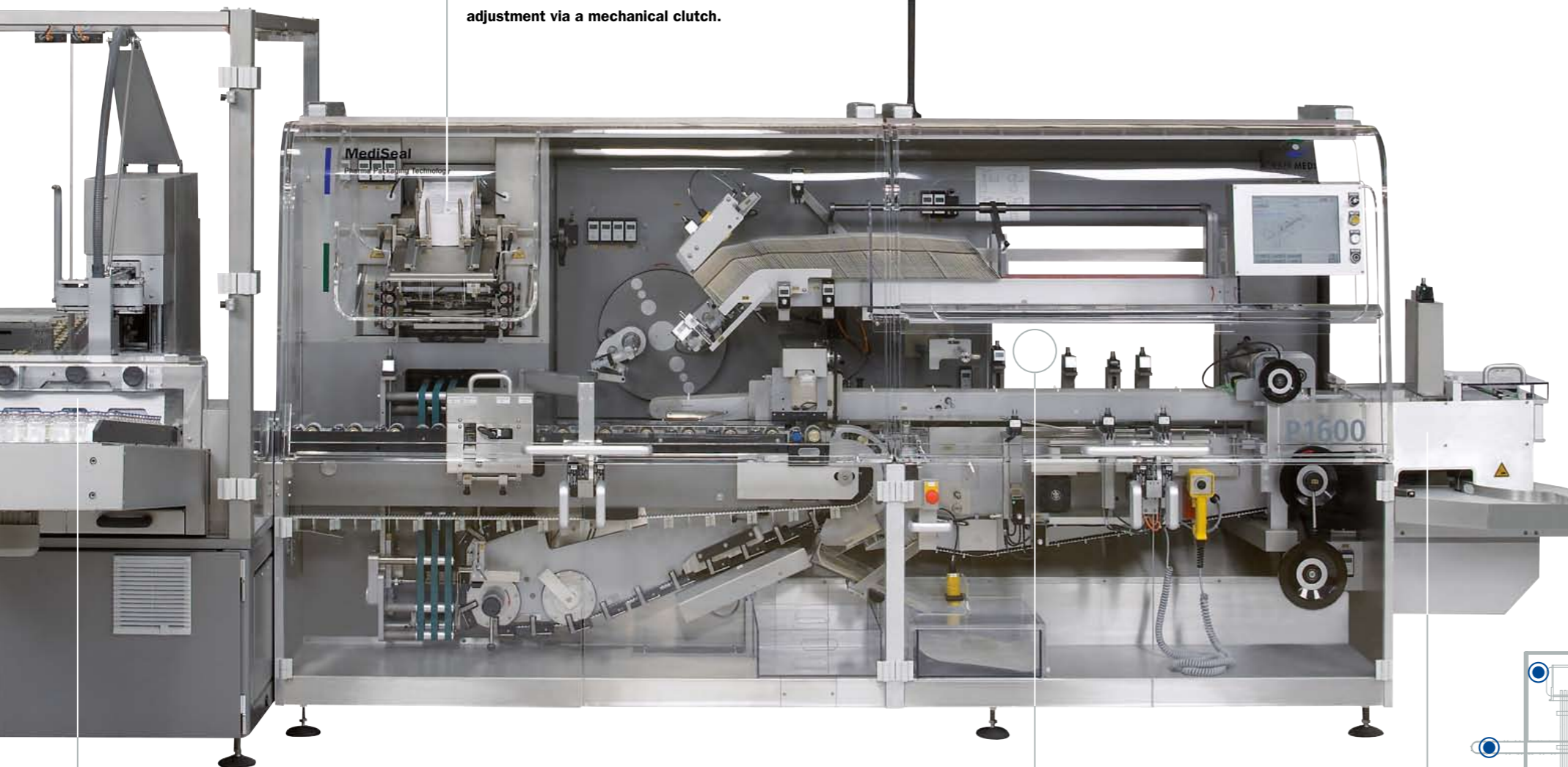

Digital servo technology guarantees perfect accessibility

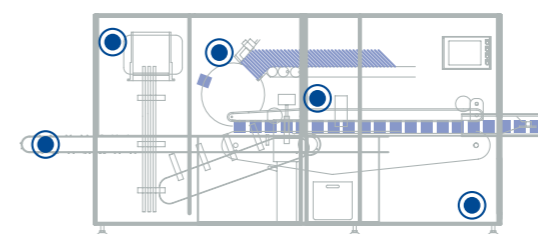

Flexibility

Vials are gently inserted, individually or in combinations, into the cartoner's cell-type product conveyor using a Pick & Place system. The feed system can use cassette systems or may operate directly via a link to the labeller.

Intelligent balcony-type construction provides rear access to the sealing stations.

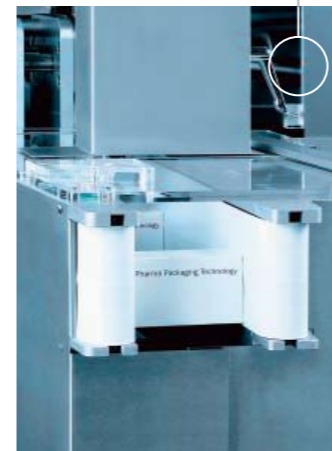

At the cartoner discharge, packs are guided on both sides. Their position and location are well-defined, so labels, for example, can be applied easily.

An ACOPOS servo drive can be replaced within minutes. The 'intelligence' of the drives is stored centrally in the machine control system. Once the drive has been replaced, the current (and validated) operating data is uploaded by the CPU to the servo motor; no programming is required.



# Flexibility thanks to modular construction

The P1600 and P3000 are also able to package dual stacks with up to 48 blisters per carton in total, without having to carry out any special modifications.

*MediSeal satisfies the need for more information in and on pharmaceutical packaging with a wide range of solutions for printing, coding and / or dispensing. The recommended systems are based on a modular construction principle and can be integrated – or retrofitted – very simply. Display and operation of selected monitoring systems take place centrally via the cartoner's KIVI user interface.*

**Digital servo technology**  
reduces set-up times

Application of variable data using laser coder or inkjet print systems replaces the use of classic debossing systems. Batch data is entered on-screen via the user interface. Correct application of variable data is verified using OCR/OCV systems.

Servo-driven dispensing systems place folded leaflets or booklets accurately in the cell-type product conveyor. Dispenser outputs can be up to 400 leaflets/min. The feed and code-reader systems are operated centrally via the cartoner's user interface.

As an alternative or complement to the classic tuck-in flap, MediSeal offers hot-melt seals. Switching from one variant to the other is simple and merely involves swapping modules. In the case of closures using a so-called 4<sup>th</sup> flap, both systems are used sequentially.

Blisters placed manually in a feed magazine are separated at a rate of up to 100 blisters per min., placed in the cartoner's cell-type product conveyor by a vacuum arm and packaged. Format changes require no tools.

Modularity



# Flexibility through transfer systems for all products

*Regardless of the packaging application, MediSeal favours the concept of direct product transfer between two machines, without intermediate stacking units. The position of a product is indexed in a shift register and is known at any point in time during the packaging process. Direct transfer reduces the use of format parts to a minimum or eliminates them entirely. The packaging line is run down automatically at the end of a batch when a button is pressed.*

Using direct blister transfer, P1600 and P3000 machines are operated inline with MediSeal blister packaging machines. Vacuum suction arms transfer the blisters directly from the fast-cycle cutting die. Satisfactory blisters are placed on the cartoner's belt conveyor whilst unsatisfactory blisters – with an ejection counter-check – are rejected. Direct transfer eliminates the need for stacking chutes and for filling and emptying them.

## Digital servo technology to suit your product

The BIB-BOB system de-stacks blisters from a thermoformer either automatically into magazines or feeds them from magazines to a cartoning process. This means that packaging of small lots can be decoupled from regular line operation.

MediSeal has developed transfer systems with up to 12 lanes for linking the P1600 and P3000 with 4 side-seal sachet machines and stickpack machines. For example, up to 25 sachets can be stacked flexibly and directly in the cartoner's cell-type conveyor chain using a 'pick & place' system.

Customised feed systems enable highly specialised products to be packaged. The picture shows the transfer to the cartoner of a child-proof blister contained in a plastic clam-type pack.

Four-axis Pick&Place systems are superbly suited to packaging small lot sizes with a high degree of variability. Their track parameters can be flexibly programmed depending on the product and any format parts which are required can be replaced quickly without any tools.

Product transfer





# Flexibility

thanks to very quick format changes

*GMP-compliant construction and a minimum number of format parts make full format changes possible in less than 30 minutes. Carton height adjustment on the P1600 and P3000 takes place automatically by motorised raising or lowering of the upper runner unit. Simultaneous guidance for the carton via upper and lower runners ensures stable transport during packaging, even for height-to-width ratios < 1.*

The P1600 and P3000 cover a wide range of formats with a minimum of format parts. Format parts are compact (individual weight < 500 g) and can be swapped simply and quickly.



Operation

## Digital servo technology minimises maintenance costs

Adjusting spindles equipped with digital displays make format conversion tables a thing of the past. When changing the format, the system indicates the setpoint in the top line. The operator simply adjusts the spindle to the pre-set value. System control verifies whether all the settings have been adjusted correctly.

The leaflet insertion system patented by MediSeal prevents blisters being pressed against the leaflet during insertion. In this way, even perforated AI-AI blisters can be pushed into the carton without imposing any pressure.

The blister stacking frame and flap folder pivot out easily from their working position for cleaning purposes. All stations are designed in detail for optimal accessibility.

### A clever and simple menu system

The menu system is clearly and simply sub-divided into settings, operation, production data capture, format memory and servicing. Format parameters are determined and learned once only, stored in the system and retrieved automatically for format conversions. Format data management and code reader system management are performed centrally via a single screen. Access authorisations are easy to manage, even in compliance with CFR21 / Part 11 regulations.

Batch report output is in the HTML file format, which can easily be adapted to individual customers' reporting systems without changing the machine's validation status. An interactive help system for all levels of operation and fault messages guides the operator interactively through the trouble-shooting process.