

# AMERIPAK®

a division of O.P. Schuman & Sons, Inc.

## MODEL 140

HORIZONTAL  
WRAPPER



The Model 140 is designed for speeds up to 140 packages per minute. **Exceptionally Compact**, the Model 140 saves valuable floor space while offering 4.5 feet of unobstructed product feeding space. A cantilevered parent roll backstand with self-centering roll cones conveniently located above the standard adjustable or fixed former can be arranged with an optional electric eye for register print wrapping materials. Full size digitally controlled fin wheels seal a wide range of heat sealable packaging materials beneath the package.

**Generous Standard Product Size Range** includes a wide film capacity backstand and end crimper which along with our adjustable film former gives you greater product size flexibility at the turn of a knob. Our heavy duty end crimper

drive assures high performance package end sealing and cut-off.

**Easy Size Changeover** with no tools required for most size changes. Unique EZ-SET end crimper phasing device allows the operator to position the crimper between the products during initial setup, then easily fine tune the setting while the machine is running!

**Easily Customized** to meet your specific needs the Model 140 is driven by a powerful motor with plenty of reserve power to drive feeding devices and other accessories. Low maintenance, wide range of product sizes, ease of changeover, rugged construction, high performance...all standard in the Model 140.

***AmeriPak... High Performance, Affordable Packaging***

---

## AMERIPAK®

a division of O.P. Schuman & Sons, Inc.

2001 County Line Road  
Phone: 215-343-1530  
Website: ameripak-ops.com

Warrington, PA 18976 USA  
Fax: 215-343-1633  
Email: AmeriPakSales@OPSchuman.com

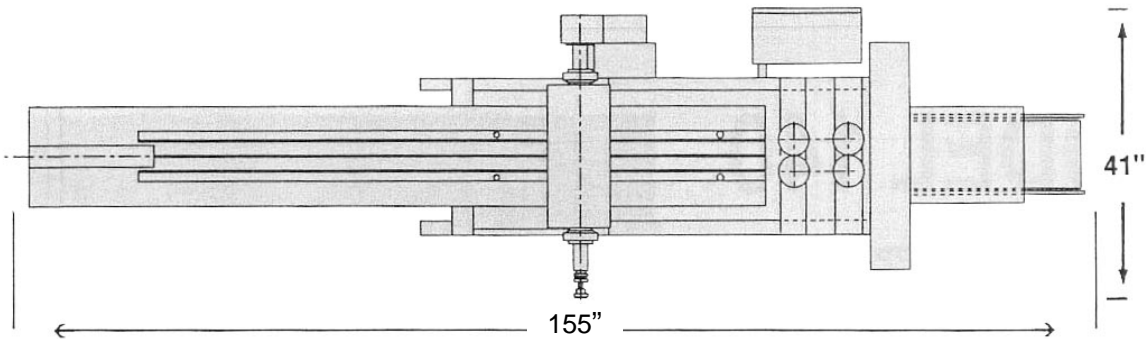

### SPECIFICATIONS

- **Machine Size (Approx.)**  
Length – 155"  
Width – 41"  
Height – 65"
- **Infeed Conveyor**  
Length – 94"  
Feed Space – 54"  
Height Above Floor – 37"
- **Wrapping Material**  
Maximum Parent Roll Diameter – 13"  
Roll Length – 20"  
1 Parent Roll
- **Fin Seal Assembly** (length seal)  
First Set – Pulling  
Second Set – Sealing  
Third Set – Pulling
- **End Crimper** (cross seal)  
1-up x 8" wide
- **Product Flow**  
Left to Right, Facing the Control Panel
- **Maximum Package Size**  
(Cannot be tolerated simultaneously)  
Length – 4" – 16"  
Width – ½" – 9"  
Height – Up to 2½"  
Larger sizes available
- **Powdercoat Finish**
- **Electrical**  
1 HP AC drive motor  
230V, 3PH, 60H
- **Weight**  
1800 lbs. base machine
- **OPTIONAL EQUIPMENT**  
Product Feeders  
Extended Infeed  
Electric Eye

SPECIFICATIONS ARE SUBJECT TO CHANGE



Simple layout of machine controls and adjustable former for quick changeover