

MODEL
CL 110

Cottoner

more than fluff



This fully automatic cottoner inserts a pre-determined length of cotton, rayon or polyester coil into containers at speeds up to 110 bottles per minute.



- Heavy duty construction
- PLC controls
- Two-station cotton insertion
- Guillotine tearing device
- Available with missing cotton & whisk detection
- Speeds up to 110 cpm

Automated with
**Rockwell
Automation**
© Allen-Bradley - Rockwell Software



A Century of Packaging Expertise

Model CL 110 Cottoner

Technical Specifications

Standard Features

- PLC control
- Two-station cotton insertion
- Guillotine tearing device
- Machine stops automatically when there is no cotton
- Photocell for container and cotton detection
- Counter for 1, 2 or 3 shots of cotton
- Spring-loaded cotton drive rollers
- Control box on slide out drawer
- Motorized height adjustment
- Back up switch
- Stainless steel cabinet
- Safety guarding
- Handles cotton, rayon and polyester

Container and Cotton / Rayon Criteria

- Container height: from 2.5" (63.5 mm) to 8" (203 mm)
- Container diameter: minimum of 1" (25.4 mm) to a maximum of 4-1/2" (114 mm)
- Neck opening: minimum of 5/8" (16 mm) to a maximum of 2-3/4" (70 mm)
- Cotton/rayon length: minimum of 3" (76 mm) to a maximum of 8" (203 mm)
- Cotton/rayon weight: 6 -16 gr (with 5/8 tube and pusher)
16 - 24 gr (with 3/4" tube and pusher)

Air & Electrical Requirements

- Air supply: 90PSIG, 11SCFM
- Power supply: 120VAC, 1 phase, 60Hz, 5A

Overall Measurements

- Length: 30-1/4" (0.81 m)
- Width: 30-1/4" (0.81 m)
- Height: 68" (1.7 m)
- Weight: 500 lbs (226.8 kg)
- Noise: 72 db

Available Options

- Conveyor
- Missing cotton and whisk detection

Authorized NJM Packaging Sales Representative

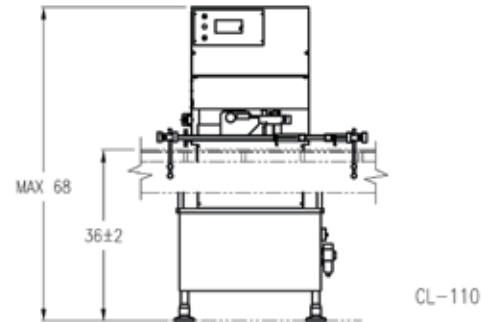
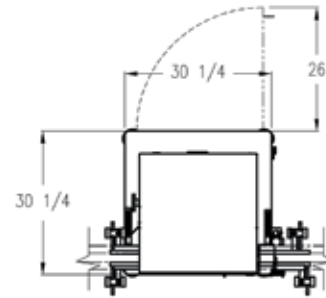

Floor Plan

Dimensions shown are for basic machines and may vary depending on options. In view of our policy of continuing research and product improvement, actual specifications may vary from those shown. Please consult with an NJM Packaging representative regarding your specific requirements.

All NJM Packaging equipment is covered by a one year warranty on parts. A comprehensive nationwide service, parts, and sales support program is available for the life of your equipment. A customized Preventative Maintenance Program for this equipment is also available.

Contact our Customer Service Department at (603) 448-3940 for more information.

This equipment can be purchased separately or as part of a fully integrated packaging line. Contact your sales representative for full details on other packaging equipment and complete turnkey line integration services.

Protected by one or more U.S. and foreign patents.



A Century of Packaging Expertise

USA 56 Etna Road
Lebanon, NH 03766 USA
1-800-432-2990

CANADA 5600 Kieran, Montreal QC
Canada H4S 2B5
1-800-811-6990
www.njmpackaging.com

Copyright © 2011 NJM Packaging

