

Comitrol® Processor Model 1700

Controlled Particle Size Reduction



SPECIFICATIONS

Length: 50.69" (1288 mm)
 Width: 33.31" (846 mm)
 Height: *72.13" (1832 mm)
 Net Weight: 1100 lb (499 kg)
 Motor: 15, 30, or 40 HP (11.2, 22.4, or 30 kW)

APPLICATIONS

The Comitrol Processor Model 1700 accommodates all three types of reduction heads which enables a broad spectrum of product processing capabilities. It is recommended for free-flowing dry and semi-dry product applications including textured vegetable protein, peanut butter, chicken slurries, surimi, baby food, dehydrated potato flakes, fruit and vegetable pastes, horseradish and dressings, extruded products, biscuits and cookies, nuts, fruit pulp, various spices, corn masa, hard cheeses, and a variety of gels, ointments, and creams.

This precision cutting principle has proven to be a processing breakthrough, with the versatility to meet your size reduction needs from coin size particles to fine emulsions. Standard operations include comminuting, granulating, milling, flaking, slicing, liquefying, dispersing, and pureeing.

Sealed enclosure deters escape of dust, vapor, and liquid when the Comitrol Processor is installed in conjunction with a collection system. Stainless steel construction ensures maximum durability and sanitation. The machine features continuous operation for uninterrupted production, and is designed for easy cleanup and maintenance.

TYPES OF CUTS

Particle sizes ranging from coarse to fine emulsions are possible. To ensure the proper combination of cutting parts, Urschel Laboratories, Inc. recommends your product be tested in one of our worldwide Product Test Facilities free-of-charge to find the most efficient solution to your size reduction needs.

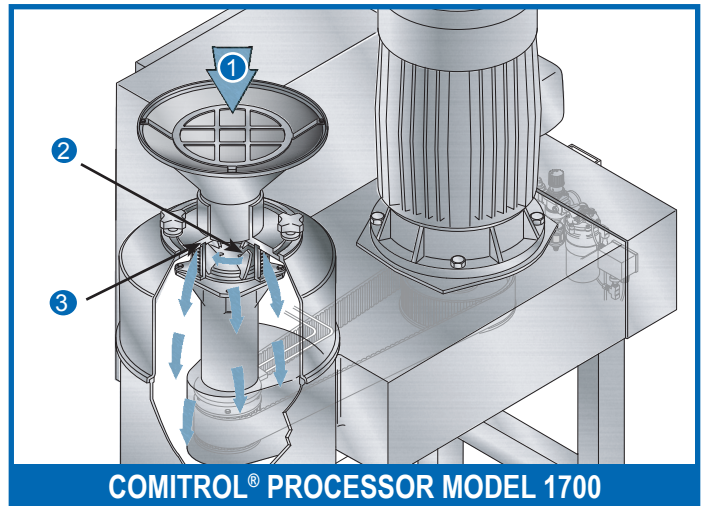

OPERATING PRINCIPLE

Product [1] is guided to the high speed, rotating impeller. When product reaches the impeller [2], it revolves at a high speed inside the cutting head [3]. Centrifugal force propels the product outward past the cutting edges of the stationary reduction head. Small portions of product projecting into the spaces between the separators are cut off into flakes by spaced columns of vertical knives. These flakes fly outward and away from the cutting head. The wall surfaces between the vertical knives are relieved to eliminate rubbing friction that would produce heat.

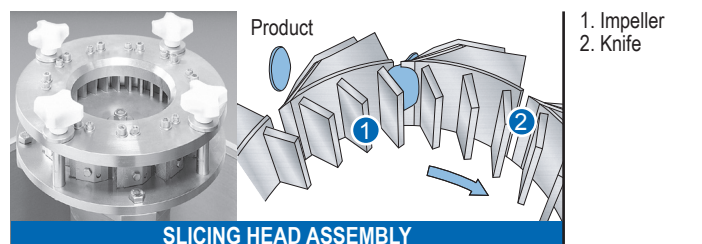
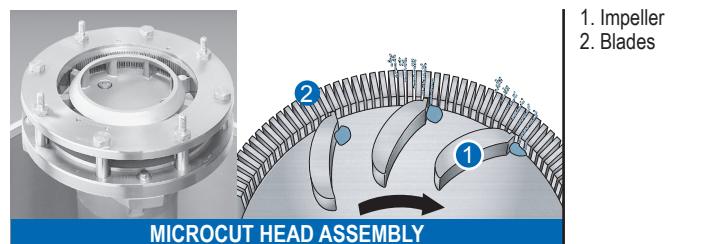
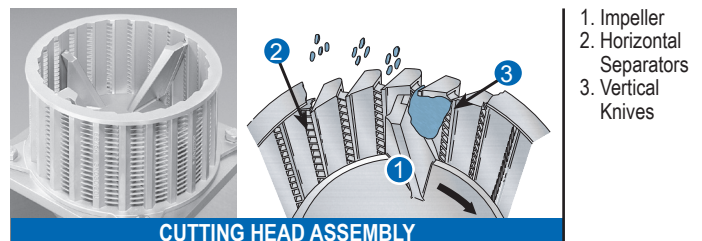

If your product application is not mentioned on this page, contact your local Urschel representative to determine the most effective solution to your size reduction needs.

(over)

Comitrol® Processor Model 1700 Dimensional Drawing

DIMENSION "A" VARIES WITH FEED ASSEMBLY.
(CONSULT URSCHEL LABORATORIES)

DIMENSION "B" (DIA.) VARIES WITH FEED ADAPTER.
(CONSULT URSCHEL LABORATORIES)

*USUAL HEIGHT WITH 40 H.P. MOTOR IS SHOWN. THIS HEIGHT WILL VARY
DEPENDING ON HORSEPOWER AND MOTOR MANUFACTURER. CONSULT
URSCHEL LABORATORIES, INC. TO DETERMINE SPECIFIC HEIGHT.

18.61" (473 mm) RADIUS ON
PATH OF OPEN DOOR

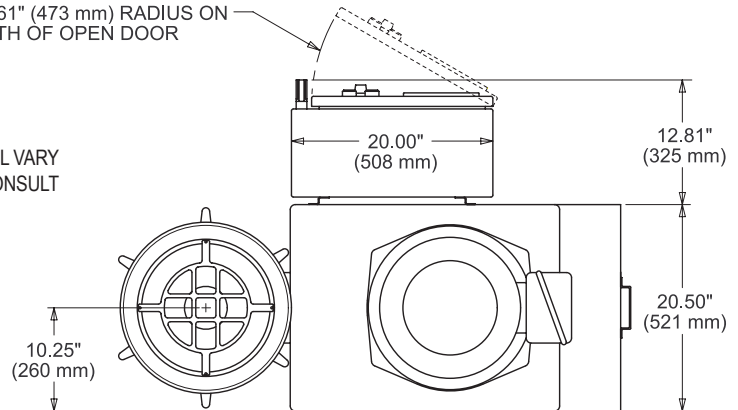

NOTE: GREASE SPINDLE VERSION
OF COMITROL 1700 WILL NOT
HAVE OIL MIST LUBRICATOR

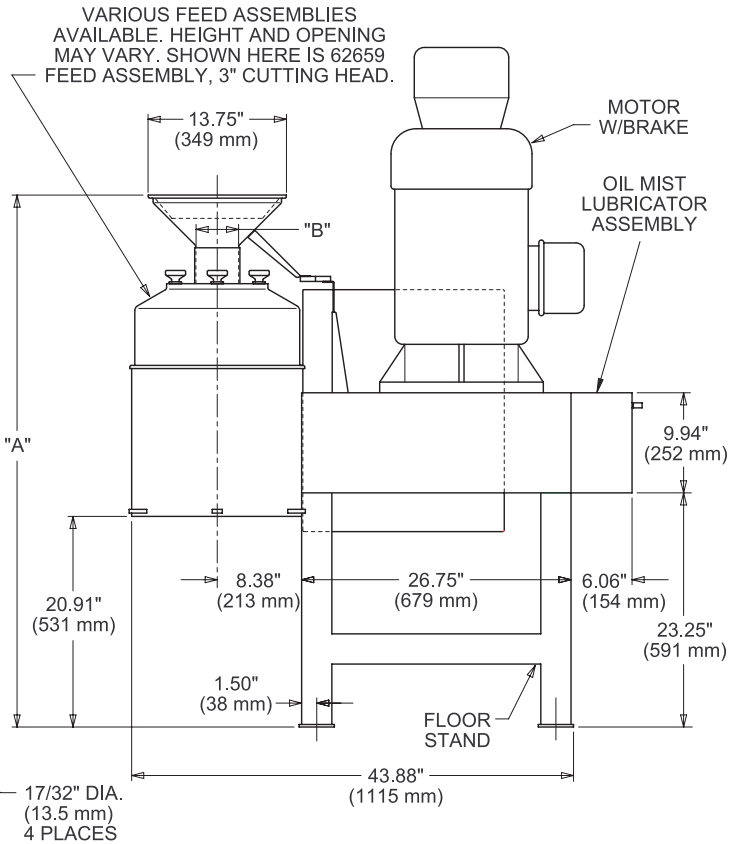
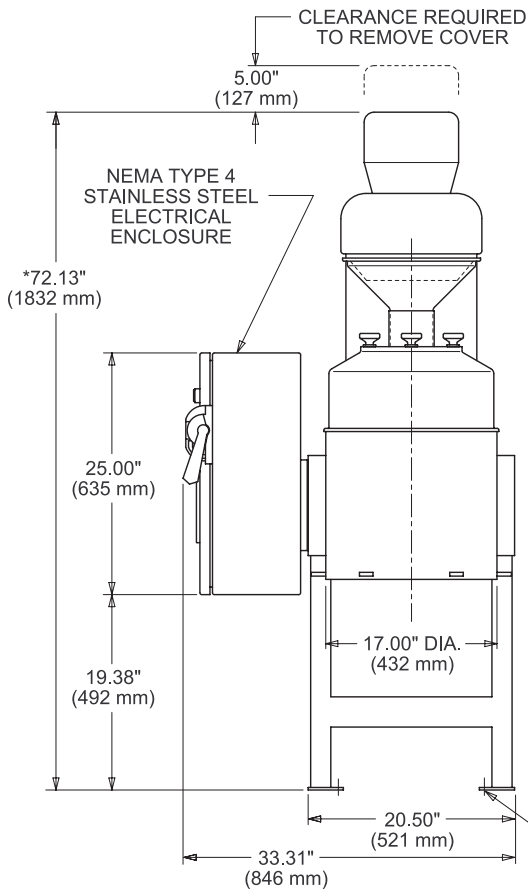

You Are Invited to Test Cut Your Product

Urschel Laboratories has a complete network of test facilities and experienced service and sales representatives around the world ready to work for you on any size reduction application. Contact your local Urschel Laboratories' representative to schedule a comprehensive, no-obligation test today at www.urschel.com.



URSCHEL®
THE SIZE REDUCTION SPECIALISTS

www.urschel.com | info@urschel.com