

ULTIMATE Is Our Standard™

StandardKnapp
StandardKnapp

an EMPLOYEE owned company

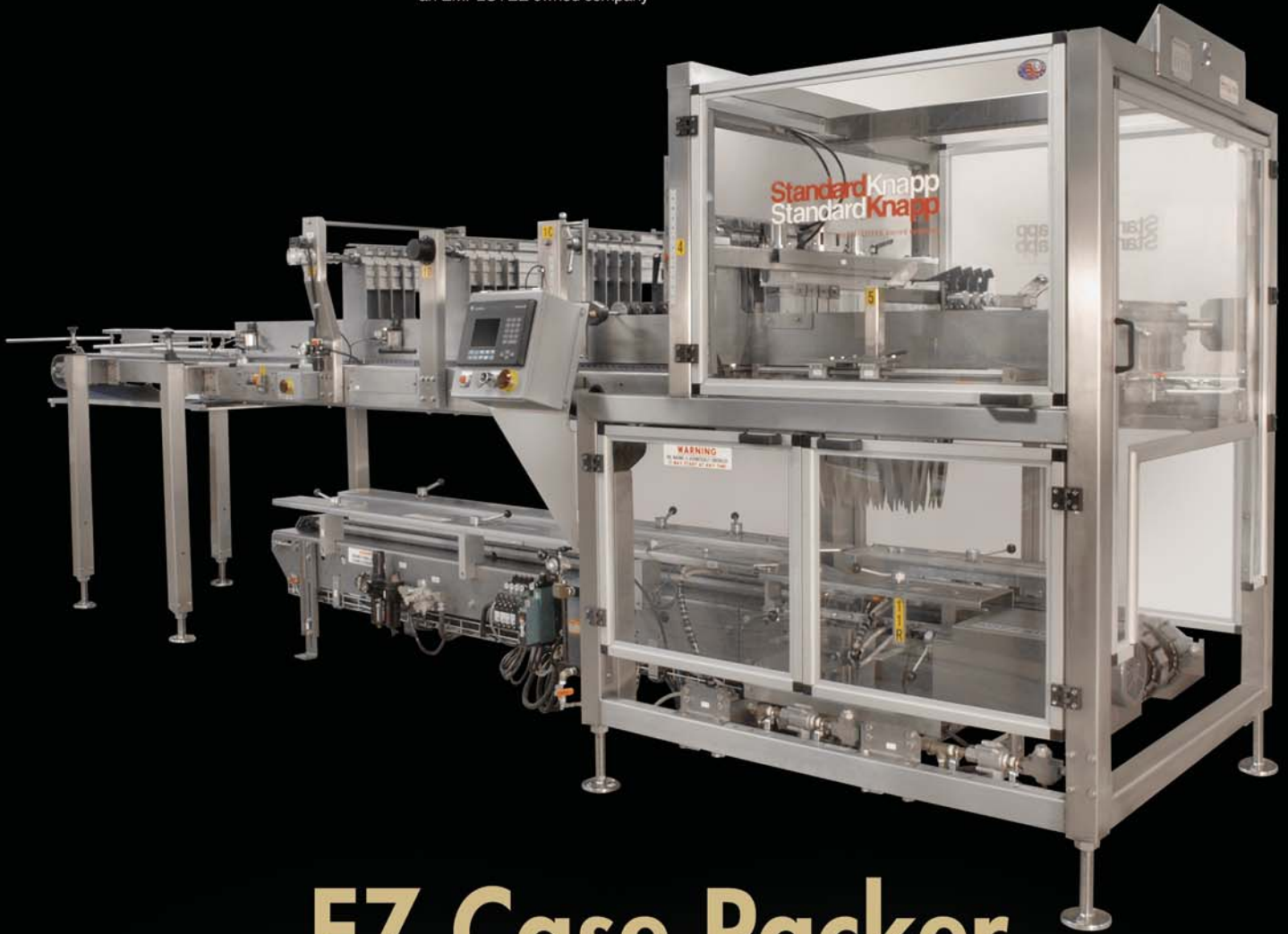

EZ Case Packer

The low-cost alternative where quality and reliability matter



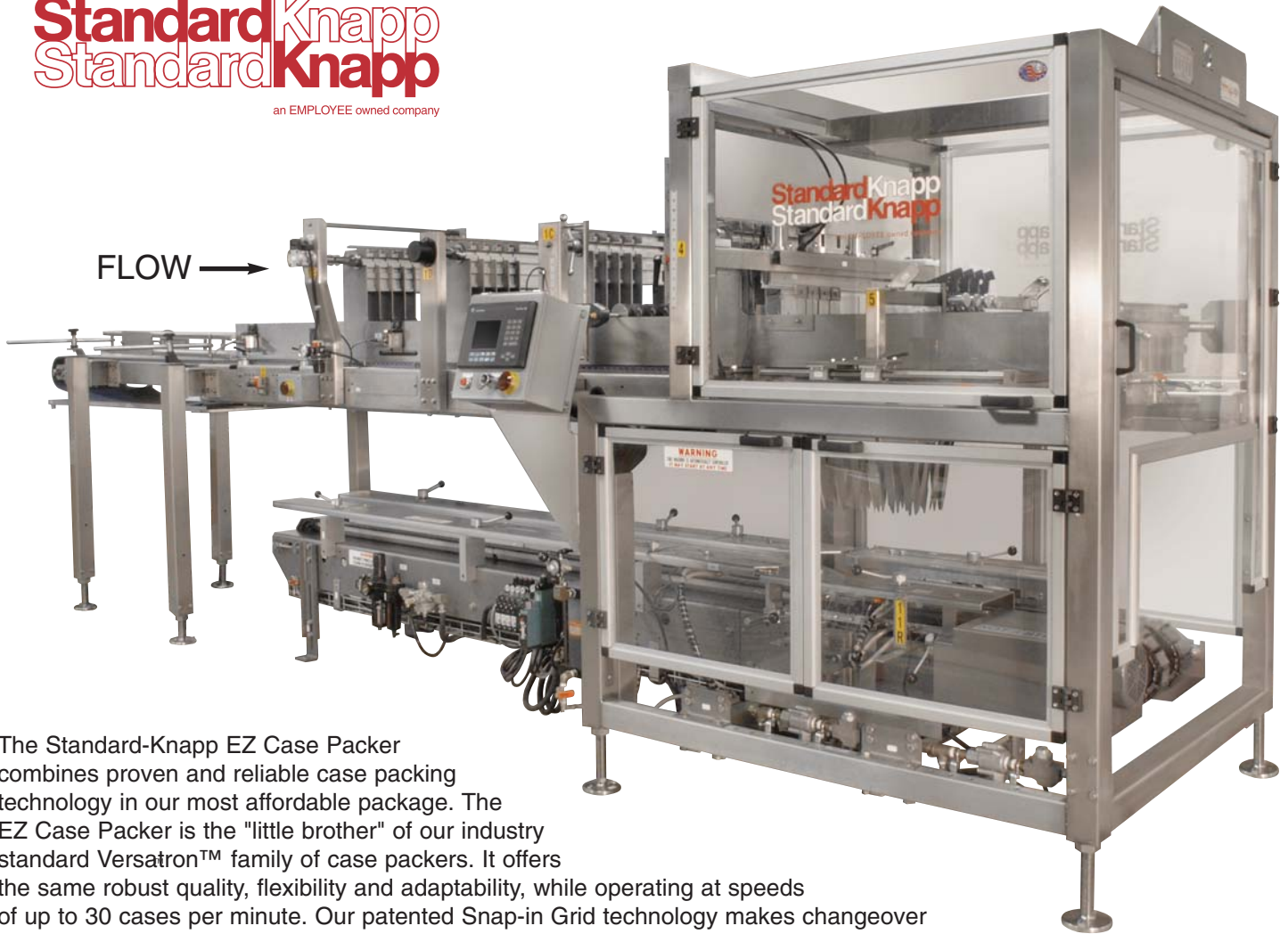

The Standard-Knapp EZ Case Packer combines proven and reliable case packing technology in our most affordable package. The EZ Case Packer is the "little brother" of our industry standard Versatron™ family of case packers. It offers the same robust quality, flexibility and adaptability, while operating at speeds of up to 30 cases per minute. Our patented Snap-in Grid technology makes changeover an easy, one-man operation. The use of our air-over-oil lift table to control the descent of product into the case maintains design simplicity without sacrificing control.

The EZ Case Packer – It fits your demand, it fits your floor plan, it fits your budget.

Robust Construction

Stainless steel tubular frame

High Reliability

Designed for 24/7 operation

Simple Operation

Fast, easy operation

Easy Walk-by Maintenance™

See-through safety guarding

Flexible and Adaptable

To future applications

Quality Fit and Finish

EZ Case Packer

StandardKnapp
StandardKnapp
 an EMPLOYEE owned company



EZ Changeover

Simple, color-coded, by-the-numbers changeover is easy to perform, requires no tools and is very repeatable – run another product in as little as fifteen minutes



EZ Walk-by Maintenance™

See-through guarding and easy-access lubrication and inspection points make maintaining our machines a breeze



EZ Operation

Our simple touchscreen operator interface is both easy to learn and easy to use

The Packaging Process Explained

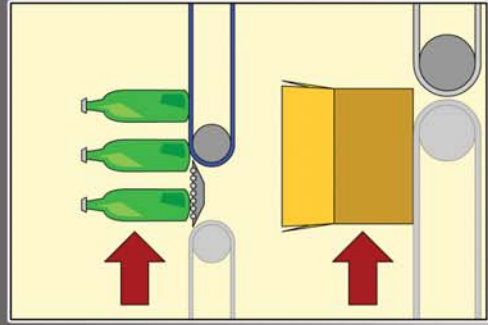

The product and the empty case enter the machine via customer conveyors

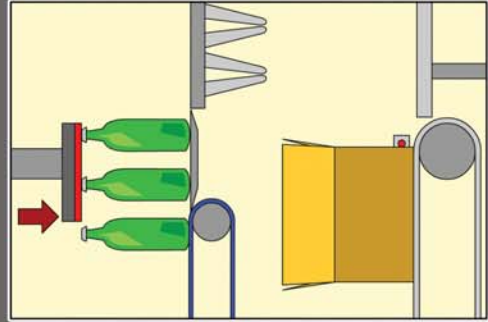

Overhead braking and case braking is applied to allow the previous slug of product and case to evacuate

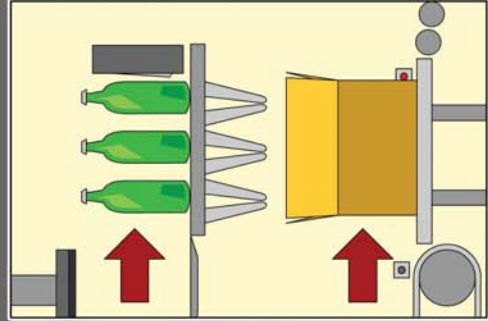

The product moves into grid area and is detected and stopped, case moves onto lift table and is detected and stopped

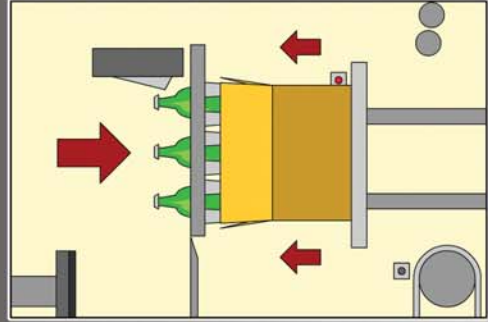

The lift table raises the case up to meet the product, which is dropped through the grid into the case

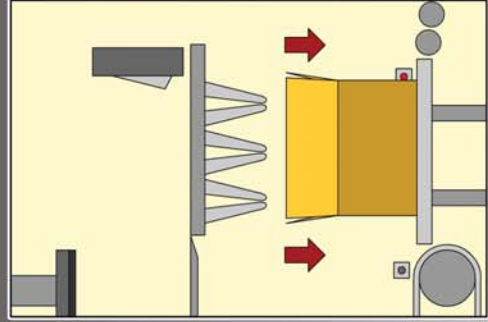

The case, now filled with product, is lowered by the lift table

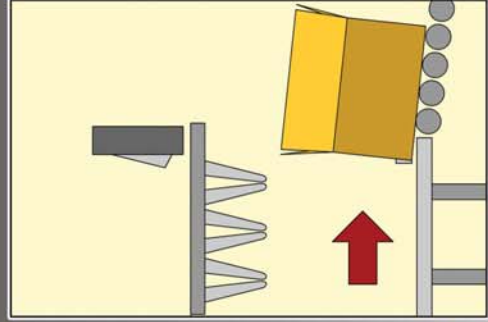

The packed case exits the machine via the discharge conveyor

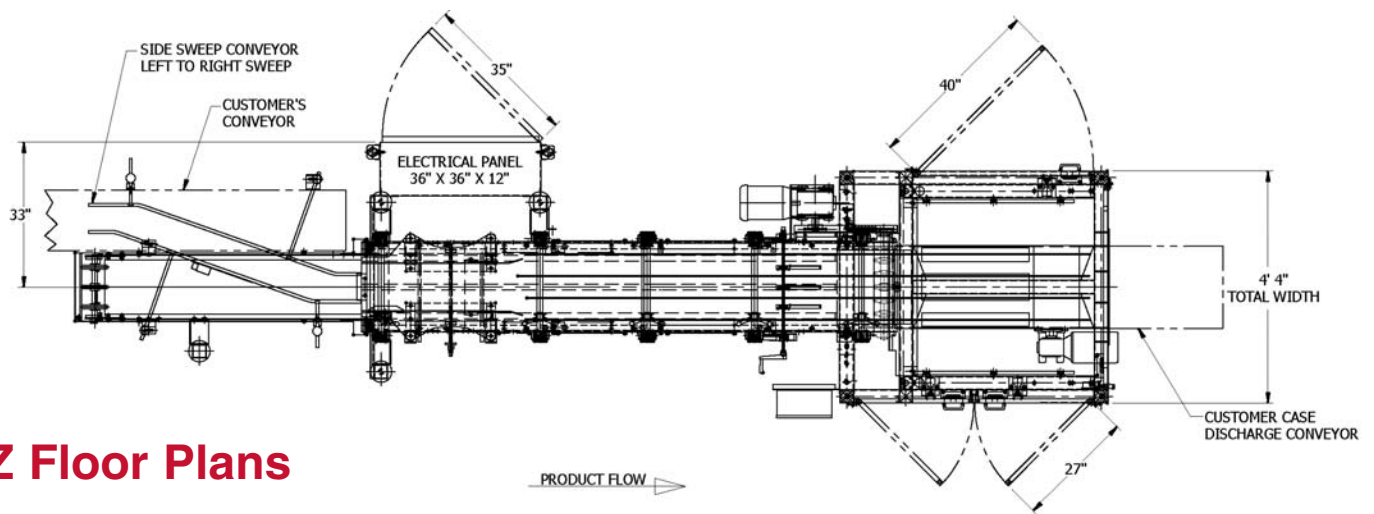

EZ Floor Plans

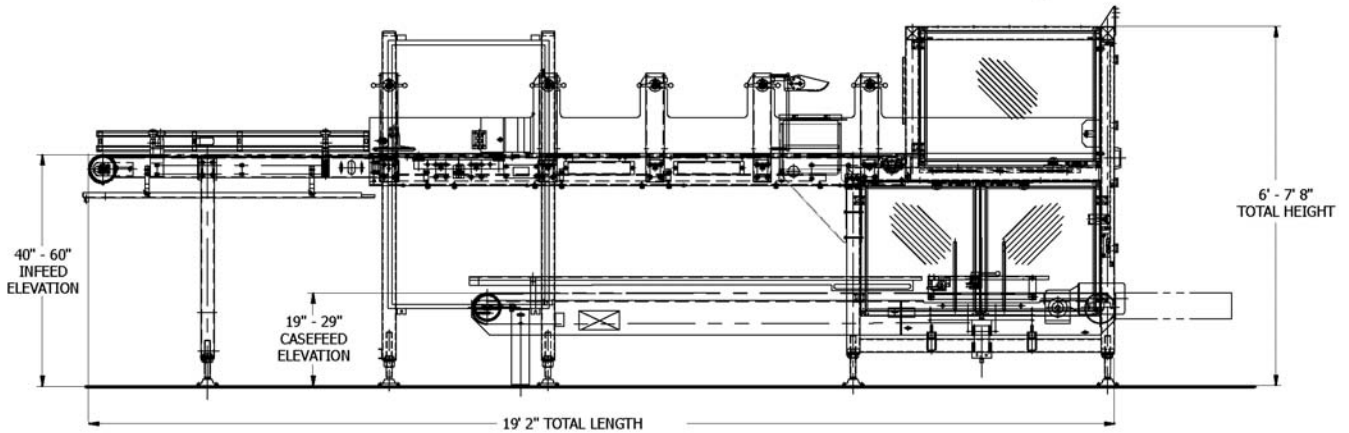

EZ Case Packer Standard Features*

The Standard-Knapp EZ Case Packer features a stainless steel packer frame over a mild steel, "Steel-it" painted casefeed and *Air Over Oil* lift table.

Model:	939EZ Case Packer	Controls:	Allen-Bradley SLC503 – 24 Volts
Speeds:	Up to 30 cpm** Up To 40 cpm Tandem**	Main Control Panel:	Nema 12, Machine Mounted
Case Types:	Plastic, Corrugated, HSC, RSC, Tablock, Tandem, Double Tier	Interface:	Allen-Bradley PanelView 600+ Color
Infeed Style:	Butt Connect or available Side Sweep onto 5' infeed extension	Electrical Supply:	230/460V – 60 HZ
Product Infeed Chain:	15" wide Intralox Series 900	Air Supply:	70 psi with 1/2" NPT
Product Lanes:	1 – 8 lanes	Lubrication:	Point lubrication
Case Sizes:	6" – 15" wide	Infeed Drive:	2 HP with VFD
Tray Height:	3" – full bottle height	Casefeed Drive:	1 HP with VFD
Industries Served:	Food, beverage, personal care	Controller:	Powerflex 40 VFD

Optional Equipment

- Flap Opener
- Panelview 1000+ with Graphically Driven HMI



* Standard-Knapp is committed to continuous product improvement. Specifications are subject to change without notice.

** Depending on Product and Cases

StandardKnapp
StandardKnapp
 an EMPLOYEE owned company

STANDARD-KNAPP, INC.
 63 Pickering Street, Portland, CT 06480 U.S.A.
SALES PHONE: (860) 342-1100, ext. 239
SALES FAX: (860) 342-1557
EMAIL: info@standard-knapp.com
WEB SITE: www.standard-knapp.com