



# How to Cut Fruit & Vegetable Products

INFO@URSCHEL.COM  
 PHONE: +219 464-4811  
 FAX: +219 462-3879

© DiversaCut, Urschel, Comitrol, QuantiCut, TranSlicer 2000, TranSlicer 2500, MicroSlice, and Velocicut are registered trademarks of Urschel Laboratories, Inc.

†The QuantiCut Dicer may contain parts protected by U.S. Patent Nos. 5993069, 6314849, 6561067, and 6883411. Foreign patents pending.

‡The DiversaCut 2110 Dicer may contain parts protected by U.S. Patent No. 6883411. Foreign patents pending.

¥ The Model OC may contain parts protected by U.S. Patent No. 5002284.

††The TranSlicer 2000 may contain parts protected by U.S. Patent Nos. 5896801, 5992284, 6148702, 6792841, and 61487094. Foreign patents pending.

β MicroSlice may contain parts protected by U.S. Patent No. 5992284. Foreign patents pending.

‡‡The Model CC Slicer may contain parts protected by U.S. Patent No. 5694824.

‡The TranSlicer 2500 may contain parts protected by U.S. Patent Nos. 5896801 and 6460444 and by European Union Patent No. 0759837B1.

§The Model VSC may contain parts protected by U.S. Patent Nos. 5343623 and 6553885.

§§The Velocicut may contain parts protected by U.S. Patent Nos. 5343623, 5875697, and 6553885 and European Patent No. EP0570153.

¥¥ The Comitrol Processor may contain parts protected by U.S. Patent No. 5201469.



DIVERSACUT 2110®  
DICER



TRANSLICER 2000®  
CUTTER

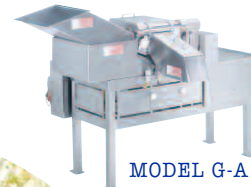

MODEL G-A



MODEL RA-A



MODEL OV



MODEL OC



MODEL VSC



COMITROL® PROCESSOR  
MODEL 9300 WITH FEEDER



COMITROL® PROCESSOR  
MODEL 9300



COMITROL® PROCESSOR  
MODEL 3600 SLANT



COMITROL® PROCESSOR  
MODEL 1700



QUANTICUT®  
DICER



TRANSLICER 2500®  
CUTTER



MODEL CC



Click on a machine

## Urschel Test Cutting Facilities

Urschel Laboratories, Inc. offers a complete Product Test Cutting Facility on-site at their manufacturing headquarters in Valparaiso, Indiana, U.S.A. Other complete product test cutting facilities are located worldwide. Product test cutting facilities offer extensive, complete analysis by experienced staff to determine the best Urschel machine suited for your application. To schedule a comprehensive test at no-charge or obligation, contact your local Urschel sales representative.



**URSCHEL**  
 LABORATORIES INCORPORATED

2503 Calumet Avenue, P.O. Box 2200  
 Valparaiso, Indiana 46384-2200 U.S.A.  
 219/464-4811 Fax: 219/462-3879  
 http://www.urschel.com  
 E-mail: info@urschel.com

Designers and manufacturers of  
 precision size reduction equipment.

L2027ONLINE AUG 2006

www.urschel.com

©Urschel Laboratories 2006. No unauthorized use of any information contained herein without the express written consent of Urschel Laboratories.

# Urschel Model RA-A

Uniformly Dice, Strip Cut or Slice

[Return to Main Menu](#)

## Applications

The Urschel® Model RA-A is a versatile machine capable of producing a wide range of dice and strip cut sizes from a variety of fruits and vegetables. Interchangeable drive parts provide maximum versatility and optimum cutting results in the small to intermediate size range. The Model RA-A features continuous operation for uninterrupted production and simplified design for easy cleanup and maintenance. Maximum input product size is 3-1/2" (88.9 mm) in any dimension.

## Types of Cuts

**DICES:** A slicing knife, circular knife spindle, and crosscut knife spindle are used for dicing. Changing the size of the cubes is done by using the required cutting spindles and adjusting the slice thickness.

*Slice thickness: 1/16 to 3/8" (1.6 to 9.5 mm)*

*Circular knife cuts: 1/8 to 1" (3.2 to 25.4 mm)*

*Crosscut knife cuts: .05 to 3" (1.3 to 76.2 mm)*

**STRIP CUTS:** Removal of the crosscut knife spindle and shaft will enable strip cutting to produce strips of different lengths as determined by incoming product size. A circular spindle change may also be required.

## Specifications

Length: 39.32" (999 mm)

Width: 36.56" (929 mm)

Height: 62.68" (1592 mm)

Net Weight: 700 lb (318 kg)

Motor: 5 HP (3.7 kW)

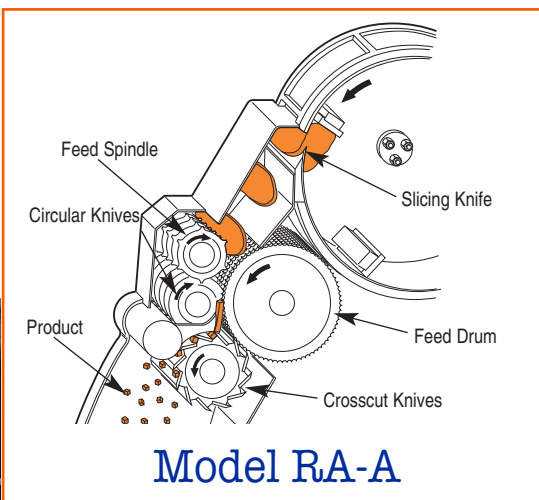

PICKLE RELISH  
1/8 x 1/8 x 1/4" (3.2 x 3.2 x 6.4 mm) Dice



PINEAPPLE  
1/4" (6.4 mm) Dice



GREEN PEPPERS  
(Cored and Halved) 3/8" (9.5 mm) Dice



CITRUS PEEL  
3/8 x 1/8" (9.5 x 3.2 mm) x random

# Urschel Model G-A

Versatile Slicer, Strip Cutter & Dicer

[Return to Main Menu](#)

## Applications

The versatile Urschel Model G-A uniformly cuts dices, straight french fry strips, and slices from a variety of soft ripe fruits and brittle root vegetables. A wide selection of interchangeable cutting parts enables the user to obtain gentle, clean cutting through a wide range of sizes at high production capacities. The Model G-A features continuous operation for uninterrupted production, and simplified design for easy cleanup and maintenance. Maximum input product size is 5-1/2" (139.7 mm) in any dimension.

## Types of Cuts

**SLICES:** By removing the crosscut knife spindle, the circular knife spindle, and the stripper plate, the Model G-A can make slices up to 3/4" (19.1 mm) with the addition of optional parts.

**DICES:** A slicing knife, crosscut knife spindle, and circular knife spindle are used for dicing. Changing the size of the cubes is done by using the required cutting spindles and adjusting the slice thickness. Cubes up to 3/4" (19.1 mm) may be obtained.

**STRIP CUTS:** To make strip cuts, only the slicing knife and the crosscut knife spindle are used. Strip cuts up to 17/32" (13.5 mm) may be obtained.

**JULIENNE STRIPS:** Julienne strips are also available. Contact your local Urschel sales representative for more information on the set-up for your application.

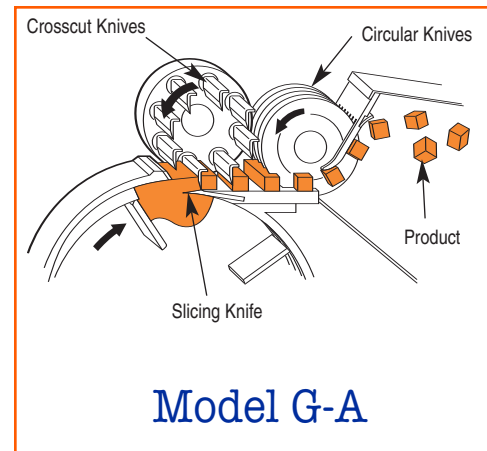
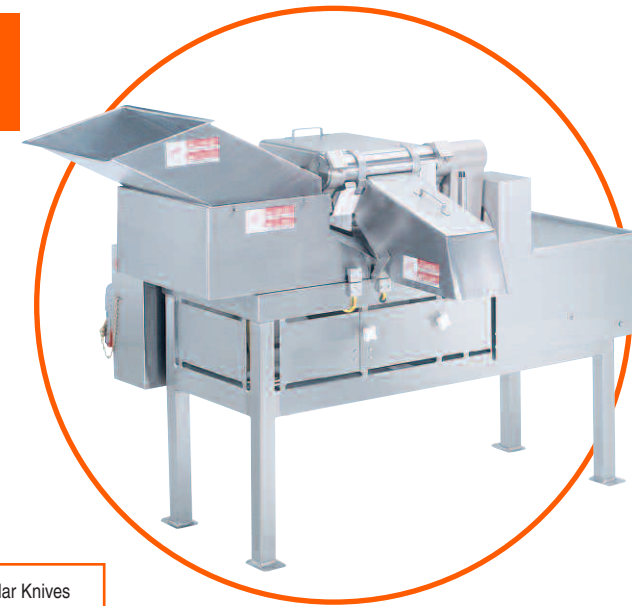

## Specifications

Length:	73.73" (1873 mm)
Width:	45.94" (1167 mm)
Height:	49.25" (1251 mm)
Net Weight:	770 lb (349 kg)
Motor:	2 HP (1.5 kW)



PEACHES  
3/8" (9.5 mm) Dice



CABBAGE  
1/4 x 3/8 x 1/4" (6.4 x 9.5 x 6.4 mm) Chop

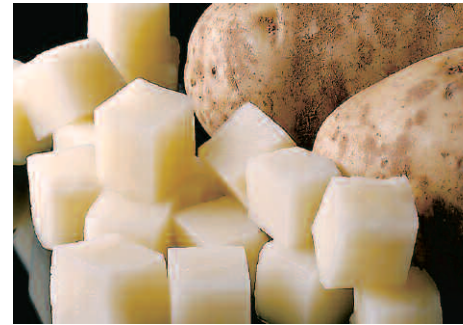

POTATOES  
3/4" (19.1 mm) Dice



TOMATOES  
1/8 x 1/8 x 1/4" (3.2 x 3.2 x 6.4 mm) Dice

# QuantiCut® Dicer

Large Product, High Capacity Slicer/Dicer/Strip Cutter

## Applications

[Return to Main Menu](#)

The QuantiCut® Dicer by Urschel Laboratories uniformly dices, strip cuts, and slices a wide variety of food products at high production capacities including potatoes, carrots, turnips, rutabagas, celery, pineapple, peppers, and a variety of other products. Further engineering innovations have simplified the changing of spindles and other parts. New †**patented** bearing design and specially designed changing tools accompany the machine including a †**patented** crosscut spindle changing tool and a †**patented** circular spindle changing tool which allow one person to change spindles without assistance. Maximum product input size is 10" (254 mm) in any dimension. The machine features continuous operation for uninterrupted production and simplified designed for easy cleanup and maintenance.



## Types of Cuts

**SLICES:** By removing the crosscut spindle, the circular knife spindle, and the stripper plate, the machine can make slices thru the full range of slice thicknesses (optional discharge chute may be required).

Straight slices: 1/16 to 1" (1.6 to 25.4 mm)

Crinkle slices: 1/8 to 1" (6.4 to 28.6 mm)

**DICES:** A slicing knife, circular knife spindle, and crosscut knife spindle are used for dicing. Changing the size of the cubes is done by using the required cutting spindles and adjusting the slice thickness.

Circular knife cuts: 5/32 to 3" (4.0 to 76.2 mm)

Crosscut knife cuts: 1/8 to 2-5/8" (3.2 to 66.7 mm)

**STRIP CUTS:** Strip cuts in a variety of widths can be made by removing either the crosscut knife spindle or the circular knife spindle assembly.

**CRINKLE CUTS:** Any slice thickness listed may be obtained with crinkle slicing knives when measuring from peak to valley.

Crinkle slices can be obtained by replacing the straight slicing knife with a crinkle slicing knife. Crinkle strip cuts can be made by substituting crinkle knives in place of the straight knives on the crosscut knife spindle.

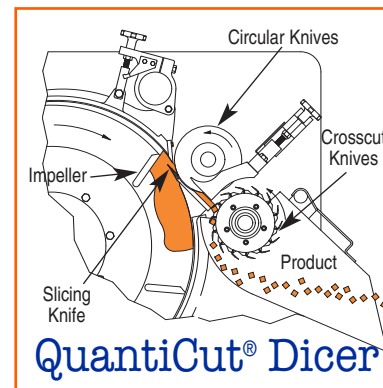

**TOMATOES**  
3/16 x 3/16 x 5/16"  
(4.8 x 4.8 x 7.9 mm)  
Dice

**POTATOES**  
1/2" (12.7mm) Deep Crinkle Strip  
Cut

**POTATOES**  
3/8x3/8" (9.5x9.5mm) Crinkle Strip Cut  
1/4 x 1/4" (6.4 x 6.4 mm) Strip Cut  
3/8" (9.5 mm) Dice  
1/4" (6.4 mm) Dice

**CABBAGE & RED CABBAGE**  
1/8 x 1/4 x 1/4" (3.2 x 6.4 x 6.4 mm) Dice  
1/8 x 1/4 x 3/4" (3.2 x 6.4 x 19 mm) Dice  
1/8 x 3" (3.2 x 76 mm) x No Crosscut Shred

**ONIONS & CARROTS**  
3/8" (9.5 mm) Dice—Onions  
3/8" (9.5 mm) Dice—Carrots  
1/8 x 1/4 x 1/8" (3.2 x 6.4 x 3.2 mm)  
Dice—Carrots

## Specifications

Length: 89.63" (2277 mm)

Width: 80.06" (2034 mm)

Height: 65.79" (1671 mm)

Net Weight: 1874 lb (850 kg)

Motor: 7-1/2 HP (5.6 kW)

[INFO@URSCHEL.COM](mailto:INFO@URSCHEL.COM)  
PHONE: +219 464-4811  
FAX: +219 462-3879

# DiversaCut 2110<sup>®</sup> Dicer

Versatile Slicer, Strip Cutter & Dicer

[Return to Main Menu](#)

## Applications

The <sup>BS</sup>DiversaCut 2110<sup>®</sup> Dicer by Urschel Laboratories uniformly dices, strip cuts, and slices a wide variety of products at high production capacities including potatoes, tomatoes, bread, carrots, turnips, rutabagas, celery, pineapple, preformed boneless turkey roasts, petfood emulsions, sugar beets, and many other applications.

**Maximum product input size is 10" (254 mm) in any dimension.** The machine features continuous operation for uninterrupted production and simplified designed for easy cleanup and maintenance.

## Types of Cuts

**SLICES:** By removing the crosscut spindle and the circular knife spindle, the machine can make slices thru the full range of slice thicknesses.

*Flat slices: 1/16 to 1" (1.6 to 25.4 mm)*

*Crinkle slices: 1/8 to 1" (3.2 to 25.4 mm)*

**STRIP CUTS:** Flat and crinkle strip cuts in a variety of widths can be made by removing either the crosscut knife spindle or the circular knife spindle assembly.

**DICES:** A slicing knife, circular knife spindle, and crosscut knife spindle are used for dicing. Changing the dice size is done by using the required cutting spindles and adjusting the slice thickness.

*Circular knife cuts: 1/8 to 3" (3.2 to 76.2 mm)*

*Crosscut knife cuts: 1/8 to 1-1/2" (3.2 to 38.1 mm)*

*Crosscut knife crinkle cuts: 9/32 to 5/8" (7.1 to 15.9 mm)*

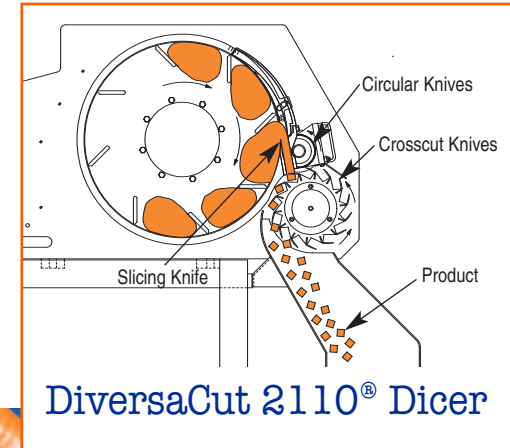

DiversaCut 2110<sup>®</sup> Dicer

[INFO@URSCHEL.COM](mailto:INFO@URSCHEL.COM)

PHONE: +219 464-4811

FAX: +219 462-3879



EGGPLANT  
3/4" (19.1 mm) Dice

CARROTS  
1/8" (3.2 mm) Strip Cuts



POTATOES  
3/8" (9.5 mm) Crinkle Strips

PEACHES  
1/2" (12.8 mm) Dice

PEPPERS  
1" (25.4 mm) Dice

ZUCCHINI  
1/4" (6.4 mm) Crinkle Slice

ONIONS  
1/4" (6.4 mm) Dice

SWEET POTATOES  
1 x 1-3/4 x 1-1/2"  
(25.4 x 44.5 x 38.1 mm)

TOMATOES  
5/8" (15.9 mm) Dice

CARROTS  
5/16 x 5/16 x 1-1/2"  
(7.9 x 7.9 x 38.1 mm)

## Specifications

Length: 64.30" (1633 mm)

Width: 59.61" (1514 mm) or 69.29" (1760 mm)\*

Height: 68.37" (1736 mm)

Net Weight: 1500 lb (681 kg)

Motor: 5 or 10 HP (3.7 or 7.5 kW)

\*width will vary depending on style of discharge chute.

# Urschel Model OV

Fast, Efficient Crosscut Slicer

[Return to Main Menu](#)

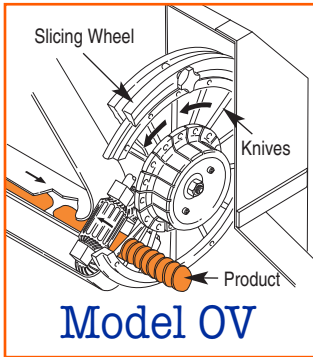

## OV Applications

The Urschel Model OV Slicer uniformly crosscut slices a wide variety of elongated food products at high production capabilities. Flat or crinkle style slices can be made from products such as carrots, celery, cucumbers, pickles, and squash. One slice is made at a time which prevents any crushing of the product. The Model OV features a wide selection of slice thicknesses from which to choose, continuous operation for uninterrupted production, and is designed for easy cleanup and maintenance. The Model OV will accommodate products up to 2-3/4" (69.9 mm) in diameter or width. The machine is not suited for slicing sticky products or products with a high concentration of sugar.

## Types of Cuts

***MODEL OV FLAT & CRINKLE SLICES:** A wide range from 1/16" to 1-3/4" (1.6 to 44.5 mm). When using crinkle knives on the Model OV Slicer, it is necessary to change the stainless steel shear edge.*



**CARROTS**  
3/8" (9.5 mm) Crinkle  
Model OV



**SERRANO PEPPER**  
1/8" (3.2 mm) Flat Slice  
Model OV



**PICKLES**  
1/8" (3.2 mm) Flat Slice  
Model OV



## OV Specifications

**Length:** 72.92" (1852 mm)

**Width:** 35.54" (903 mm)

**Height:** 49.18" (1249 mm)

**Net Weight:** 692 lb (314 kg)

**Motor:** 3 HP (2.2 kW)

# Urschel Model OC

Crosscut Bias Slicer

[Return to Main Menu](#)



## OC Applications

The Model OC Slicer is used to make a distinctive bias cut on elongated products. The machine cuts an included angle of 30 degrees with the long axis of the product. This causes the slices to be radically different in appearance than the standard crosscut pieces. One slice is made at a time which prevents any crushing of the product. The Model OC features a wide selection of slice thicknesses from which to choose, continuous operation for uninterrupted production, and is designed for easy cleanup and maintenance. The Model OC will accommodate products up to 2-3/4" (69.9 mm) in diameter or width. The machine is not suitable for slicing sticky products or products that have a high concentration of sugar.

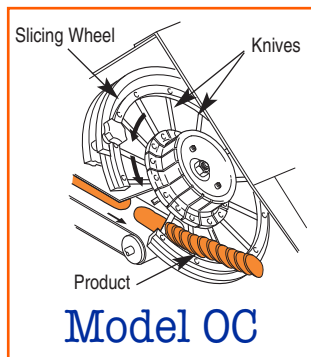

## Types of Cuts

*MODEL OC BIAS FLAT & BIAS CRINKLE SLICES: A wide range from 1/16 to 1-3/4" (1.6 to 44.5 mm)*

*MODEL OC BIAS FLAT SLICES WHEN SPECIALLY EQUIPPED WITH A MICROSLEE@ WHEEL: .030 to .120" (.8 to 3 mm). Consult factory. Requires a certified print.*

## OC Specifications

Length: 117.04" (2973 mm)

Width: 31.38" (797 mm)

Height: 44.70" (1135 mm)

Net Weight: 770 lb (349 kg)

Motor: 2 HP (1.5 kW)

Feed Belt Motor: 3/4 HP (.56 kW)



CARROTS  
1/8" (3.2 mm) Bias Flat Slice  
Model OC

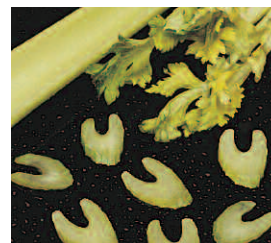

CELERY  
1/8" (3.2 mm) Bias Flat Slice  
Model OC

# TranSlicer 2000® Cutter

Slices Elongated Products with Precision at High Capacities

## Applications

The TranSlicer 2000® Cutter ††**patented** by Urschel Laboratories uniformly slices a wide variety of products at high production capacities. It is ideally suited for elongated products such as cucumbers, peppers, celery, potatoes, carrots, and a wide variety of fruits. The TranSlicer 2000 accepts firm products up to 4" (101.6 mm) in diameter and leafy-type products up to 6" (152.4 mm) in diameter. Three different types of cutting wheels: slicing wheels, **patented** MicroSlice® wheels, and julienne wheels, are available to produce a full range of slices and julienne cuts.

## Types of Cuts

### SLICING WHEEL CONFIGURATIONS

Flat and crinkle slices: 1/32 to 2" (.8 to 51 mm)

**JULIENNE WHEEL CONFIGURATIONS:** Wide range of sizes from 1/2 x 1/2" (12.7 x 12.7 mm) to 2 x 2" (50.8 x 50.8 mm).

**MICROSLICE WHEEL CONFIGURATIONS:** Flat slices: .030 to .240" (.8 to 6 mm)

Crinkle slices: .069" (1.8 mm)

Oval shred: Oval-shaped cross section measuring approximately .125" (3.2 mm) thick by .250" (6.4 mm) wide.

Julienne strips: A wide range of julienne strips can be made from firm products. Contact your local representative for more information.



PLANTAINS

MicroSlice Wheel, .080" (2.0 mm) Slice



SWEET POTATOES

MicroSlice Wheel, .060" (1.5 mm) Slice



CASSAVA

MicroSlice Wheel, .030" (0.8 mm) Slice



BANANA PEPPERS

Crinkle Slicing Wheel, 5/16" (7.9 mm) Crinkle Slice



ASPARAGUS

Slicing Wheel, 1-1/2" (38.1 mm) Cuts



ROMAINE STRIPS

Julienne Wheel, 3/8" (9.5 mm) Strip Cut

[Return to Main Menu](#)

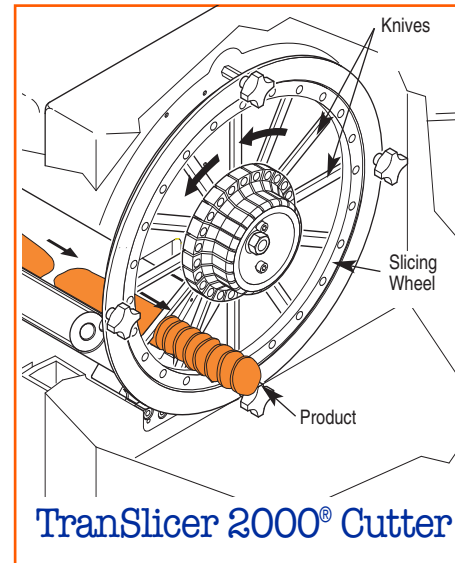

## Specifications

Length: 126.65" (3217 mm)

Width: 34.12" (867 mm)

Height: 55.75" (1416 mm)

Net Weight: 1200 lb (544 kg)

Motor: 3 HP (2.2 kW)  
(Stainless Steel, Fan Cooled)

Feed Belt Motor: 1 HP (.75 kW)  
(Stainless Steel, Fan Cooled)

[INFO@URSCHEL.COM](mailto:INFO@URSCHEL.COM) • PHONE: +219 464-4811 • FAX: +219 462-3879



# TranSlicer 2500® Cutter

Large Product, High Capacity Slicer/Shredder/Dicer

## Applications

[Return to Main Menu](#)

The TranSlicer 2500® three-dimensional cutter **patented** by Urschel Laboratories is designed to meet the food processing industry's high-speed cutting requirements for many types of large, leafy vegetables and fresh cut fruits without precutting. The machine features several Urschel® engineering innovations including one-, two-, or three-dimensional cutting in a single pass without changing product direction. The result is a clean, uniform cut at high production capacities of leafy food products such as iceberg lettuce up to 8" (203.2 mm) in diameter, or firm, round products such as cabbage up to 6-3/4" (171.5 mm) in diameter (larger cabbage heads if cut in half).

## Types of Cuts

**SLICES:** Choose from a variety of slice thicknesses on firm products ranging from 1/32 to 3-1/2" (.8 to 88.9 mm).

**SHREDS:** Wide variety available for cutting leafy vegetables. Thicknesses ranging from 1/32 to 9/32" (.8 to 7.1 mm), and lengths ranging from 3/8 to 3" (9.5 to 76.2 mm) or length of product.

**JULIENNE:** Many combinations of julienne sizes are available for cutting leafy vegetables ranging from 3/8 x 3/8" (9.5 x 9.5 mm) to 1-3/8 x 1-1/2" (34.5 x 38 mm) to 3 x 2" (76.2 x 50.8 mm). Julienne sizes on fresh fruits such as cantaloupe and honeydew, and vegetables such as potatoes and tomatoes include 1/2 x 1/2 x 1" (12.7 x 12.7 x 25.4 mm) to 1 x 1 x 1" (25.4 x 25.4 x 25.4 mm). Consult Urschel representative for more information.

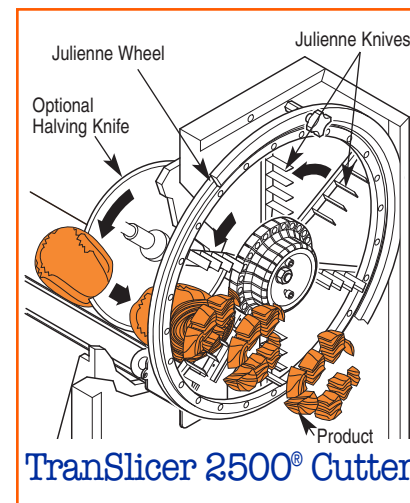

## Specifications

Length:	146.71" (3727 mm)
Width:	47.04" (1195 mm)
Height:	65.36" (1660 mm)
Net Weight:	2454 lb (1113 kg)
Motor:	3 HP (2.2 kW)
Feed Belt Motors (2):	1 HP (.75 kW)
Optional Halving Knife Motor:	1 HP (.75 kW)



ZUCCHINI  
3/16" (4.8 mm) Slice

PAPAYA  
3/4" (19.1 mm) Dice



LEEK  
1/2" (12.7 mm) Slice

KIWI  
3/16" (4.8 mm) Slice

ICEBERG LETTUCE  
1/8" (3.2 mm) Shred  
1-3/8 x 1-1/2" (34.9 x 38.1 mm) Square

CABBAGE  
1/16" (1.6 mm) Shred

# Urschel Model CC

Versatile Slicer, Shredder, and Granulator

## Applications

[Return to Main Menu](#)

The Urschel <sup>®</sup>Model CC uniformly slices, strip cuts, shreds and granulates a wide variety of fruits and vegetables at high production capabilities with excellent results. The versatile machine features interchangeable cutting heads that enable the processor to change the type of cut in just minutes. Specially designed throwaway knives do not require sharpening and are inexpensive to replace. The Model CC features continuous operation for uninterrupted production and simplified design for easy cleanup and maintenance. Maximum input product size is 3-1/2" (88.9 mm) in any dimension when using stainless steel impellers, 4" (101.6 mm) in any dimension when using manganese bronze impellers.

## Types of Cuts

FLAT SLICES: Slice thicknesses .030 to .500" (0.8 to 12.7 mm).

STANDARD CRINKLE SLICES: 3-1/3 waves to the inch, .080" (2.0 mm) depth of crinkle.

.175" CRINKLE SLICES: 5.7 waves to the inch, .084" (2.1 mm) depth of crinkle.

"V" SLICES: .125" (3.2 mm) slices have 8 complete "V"s to the inch. Depth of "V" is .050" (1.3 mm). Slice thickness of .040 to .100" (1.0 to 2.5 mm). • .212" (5.4 mm) slices have 4.7 "V"s to the inch. Depth of "V" is .084" (2.1 mm). Slice thickness of .040 to .100" (1.0 to 2.5 mm).

OVAL SHREDS: Approximately 1/8" (3.2 mm) thick and somewhat oval-shaped in cross section.

CRESCENT SHRED: Crescent-shaped cross section.

.070" (1.8 mm) Full Shred, .097" (2.5 mm) Full Shred, and .125" (3.2 mm) Full Shred: Diamond in shape.

"V" SHRED: "V"-shaped cross section.

STRIP CUTS: Square or rectangular in cross section: 3/32" (2.4 mm), 3/16" (4.8 mm), 1/4" (6.4 mm), 3/8" (9.5 mm), 3/4" (19.1 mm)



FRESH MUSHROOMS  
3/16" (4.8 mm) Slice

STRAWBERRIES  
1/4" (6.4 mm) Slice

RED CABBAGE  
.090" (2.3 mm) Flat Slice

BROCCOLI STEMS  
.125" (3.2 mm) V-Shred

## Specifications

Length:	48.07" (1221 mm)
Width:	35.26" (896 mm)
Height:	31.47" (799 mm)
Net Weight:	554 lb (251 kg)
Motor:	2 HP (1.5 kW), 5 HP (3.7 kW), or 10 HP (7.5 kW)



(shown with optional floor stand)

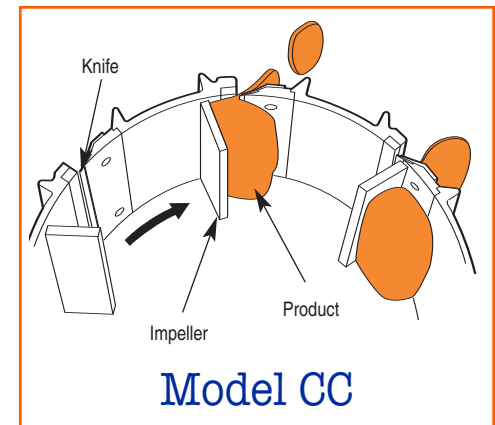

Model CC

# Urschel Model VSC

Cuts Segment, Slabs and Strips



## Applications

[Return to Main Menu](#)

The **patented** Urschel Model VSC produces a wide variety of cuts including segments, crinkle or flat slabs, and square or rectangular strips from many food products including carrots, pickles, zucchini, and potatoes. The Model VSC features a variable speed drive, hinged access panel for easy access, quick changeover of cutting heads, and simplified design for easy cleanup and maintenance. The Model VSC will accept product up to 4" (101.6 mm) in diameter and is easily adapted to automated belt feeding. The machine can be sold equipped with a feed pan and chute for hand-fed operations. For added versatility, several different cutting heads are available including the standard cutting head, slab cutting head, and the **patented** Velocicut<sup>®</sup> cutting head. Consult your local Urschel sales representative for the cutting head best-suited for your application.

## Types of Cuts

### SQUARE STRIPS

.156" (4.0 mm)	.300" (7.6 mm)	.472" (12.0 mm)
.188" (4.8 mm)	.305" (7.7 mm)	.500" (12.7 mm)
.218" (5.5 mm)	.313" (8.0 mm)	.512" (13.0 mm)
.250" (6.4 mm)	.330" (8.4 mm)	.560" (14.2 mm)
.276" (7.0 mm)	.344" (8.7 mm)	.563" (14.3 mm)
.281" (7.1 mm)	.375" (9.5 mm)	.591" (15.0 mm)
.285" (7.2 mm)	.394" (10.0 mm)	.625" (15.9 mm)
.290" (7.4 mm)	.406" (10.3 mm)	.750" (19.1 mm)
.294" (7.5 mm)	.438" (11.1 mm)	.875" (22.2 mm)
.297" (7.5 mm)	.469" (11.9 mm)	1" (25 mm)

### RECTANGULAR STRIPS

.281 x .406" (7.1 x 10.3 mm)
.281 x .594" (7.1 x 15.1 mm)
.290 x .313" (7.4 x 8.0 mm)
.313 x .375" (8.0 x 9.5 mm)
.313 x .750" (9.5 x 19.1 mm)
.315 x .385" (8.0 x 9.8 mm)
.330 x .395" (8.4 x 10.0 mm)
.344 x .469" (8.7 x 11.9 mm)
.375 x .750" (9.5 x 19.1 mm)
.438 x .750" (11.1 x 19.1 mm)
.438 x .875" (11.1 x 22.2 mm)

### SEGMENT CUTS:

3, 4, 5, 6, 8, 10, or 12

**SLABS:** Crinkle and flat slab cut sizes are available to meet your product requirements.

Length: 116.48" (2959 mm)

Width: 32.61" (828 mm)

Height: 54.81" (1392 mm)

Net Weight: 1028 lb (466 kg)

Motor: 3 or 5 HP (2.2 or 3.7 kW)

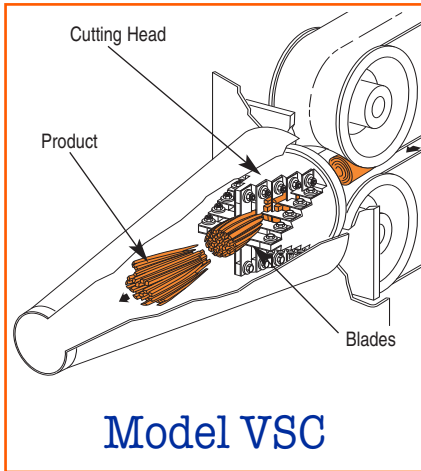

EGGPLANT  
3/8" (9.5 mm) Slab Cut

INFO@URSCHEL.COM • PHONE: +219 464-4811 • FAX: +219 462-3879



POTATO  
5 and 6 Segment Cut

APPLES  
3/16" (4.8 mm) Crinkle Slabs

ONION  
3/16" (4.8 mm) Slices with Rings Intact

CARROTS  
3/8" (9.5 mm) Carrot Sticks

# Comitrol® Processors

Comminuting Machines

## Comminution

[Return to Main Menu](#)

Comminution is the process of reducing a product to a smaller size. Conventional methods of comminution employ some type of grinding, smashing, or tearing action which can produce excessive heat and degrade the quality of the finished product. This can also generate a higher percentage of particles which fall outside the target range of the desired particle size and negatively impact the yield, quality, and final particle size.

## Controlled Comminution

The word “Comitrol” means controlled comminution. The <sup>™</sup>Comitrol® processor uses the principle of incremental shear to ensure highly efficient comminution by rotating the product inside a stationary reduction head at high rotational speeds. In addition, continuous single pass operation achieves consistently uniform particle size reduction at high capacities. The result is the most efficient type of comminution available today. The versatile Comitrol processor has been used in thousands of processing applications throughout the world on a variety of food, chemical, and pharmaceutical products. Twelve Comitrol models are available to meet your processing requirements.

## Comitrol Versatility

- Various consistencies from dry to paste to liquids
- Precision particle size reduction down to microdimensions
- Wide spectrum of product applications
- Standard operations include:

- |                    |                   |                     |                    |
|--------------------|-------------------|---------------------|--------------------|
| <b>Granulating</b> | <b>Milling</b>    | <b>Flaking</b>      | <b>Shredding</b>   |
| <b>Slicing</b>     | <b>Liquefying</b> | <b>Homogenizing</b> | <b>Emulsifying</b> |
| <b>Blending</b>    | <b>Pureeing</b>   | <b>Dispersing</b>   |                    |



COMITROL® PROCESSOR  
MODEL 1500



COMITROL® PROCESSOR  
MODEL 1700



COMITROL® PROCESSOR  
MODEL 3600 SLANT



COMITROL® PROCESSOR  
MODEL 9300 (with feeder)



COMITROL® PROCESSOR  
MODEL 9300

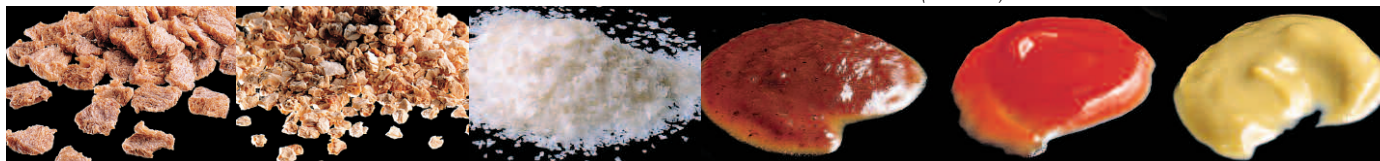

TEXTURE  
VEGETABLE PROTEIN  
Model 1700  
3K-030500U  
Cutting Head

DEHYDRATED  
LEMON PEEL  
Model 1700  
3K-030060U  
Cutting Head

POTATO FLAKES  
Model 3610  
3M-025040U  
Cutting Head

CHILI PASTE  
Model 1500  
140084  
Microcut Head

TOMATO CATSUP  
Model 1500  
200084  
Microcut Head

BABY FOOD-PEAS  
Model 9300  
234156(-.25)  
Microcut Head

