

Trittico Executive 183

Combined machine with ionic-system and double inverter for pastry products, chocolate, savoury food and gelato water cooled

Model:
 Quantity:
 Project:
 Company:
 Contact:
 Dealer ID:

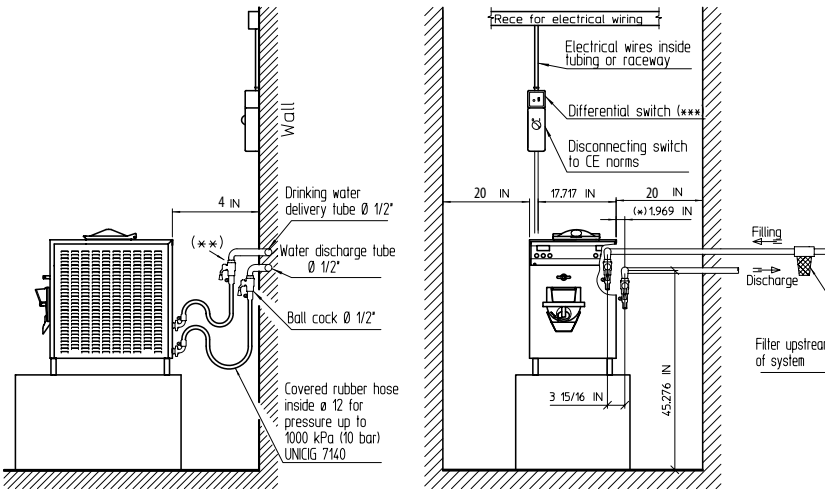
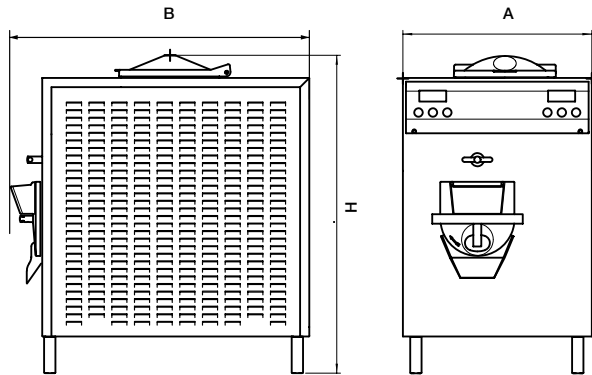

side view

front view

(*) Even if the machine models vary, the water and electricity connection positions are always the same, i.e. on the LEFT side of the machine.
 (**) The cock is higher for illustration requirements. In really it must be placed side by side with the other.
 (***) 300 mA (ABB serie K)

Width (A)	cm	50	inches	19,7
Depth (B)	cm	81	inches	32
Height (H)	cm	84	inches	33,1
Weight	kg	122	lbs	269
Frame type	countertop			
Outer panels	stainless steel			
Capacity per cycle	Liters	3	Gal	0,8
Max. hourly production for gelato	Liters	18	Gal	4,75
Max. hourly production for pastry	based on the product that has to be produced			
Min. mix per cycle	Kg	1,5	Lbs	3,3
Max. mix per cycle	Kg	2,5	Lbs	5,5
Volume cylinder with mixer	Liters	5,7	Quarts	6
Volume cylinder without mixer	Liters	6,1	Quarts	6,5
Stirrer speed	3 speeds from 30 to 110 RPM			
Mixer speed	8 speed from 20 to 240 RPM			
Max power	kw	5,3	Hp	7,1
Voltage	230 Volt / 60 Hz / 3 phase			
Running Amps	Amp 17,7			
Breaker size	Amp 30			
Stirrer motor	kw	0,22	Hp	0,3
Drive motor	kw	1,1	Hp	1,5
Compressor power	kw	1,2	Hp	1,6
Compressor power	BTU/h 3200			
Freon R404A	Gr	1150	Oz	40,5
Refrigeration condensation	Water			
Water connection	cm	1,27	inches	1/2
Min. water pressure	bar	1,5	psi	20
Max. water pressure	bar	3	psi	40
Crate dimensions	cm	100X63X105	inches	39,4x24,2x41,3
Crate weight	kg	170	lbs	374



Warranty: valid for the North American Continent (Canada, USA)
 Extension: 12 months parts (with check list and warranty signed and mailed)
 5 years compressor with registration on warranty.bravonorthamerica.com



Bravo North America Inc. Office & Showroom, 810 Tyvola Road, Suite 130, Charlotte, NC 28217
 tel. +1 980 237 2474 bravonorthamerica.com info@bravonorthamerica.com

Trittico Executive 183

Combined machine with ionic-system and double inverter for pastry products, chocolate, savoury food and gelato
air cooled

Model:
Quantity:
Project:
Company:
Contact:
Dealer ID:

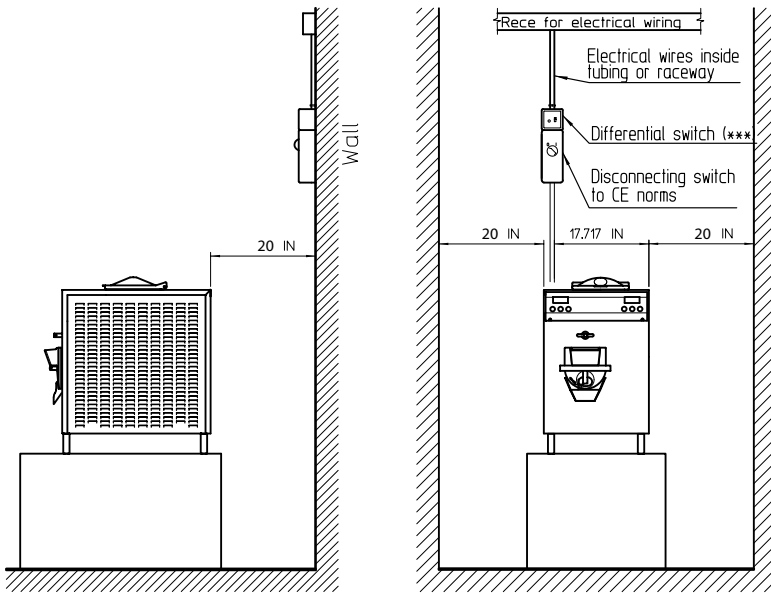
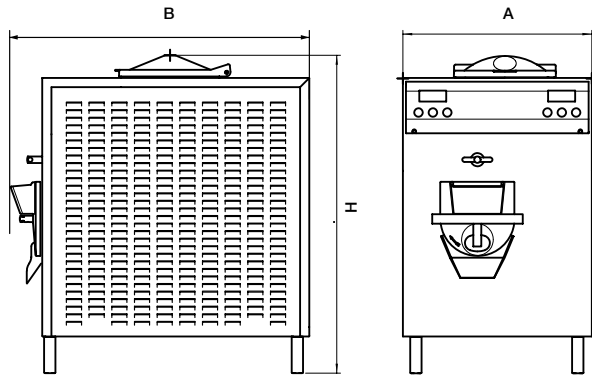

side view

front view

(***) 30 mA (ABB serie C).

Width (A)	cm	50	inches	19,7
Depth (B)	cm	81	inches	32
Height (H)	cm	84	inches	33,1
Weight	kg	122	lbs	269
Frame type	countertop			
Outer panels	stainless steel			
Capacity per cycle	Liters	3	Gal	0,8
Max. hourly production for gelato	Liters	18	Gal	4,75
Max. hourly production for pastry	based on the product that has to be produced			
Min. mix per cycle	Kg	1,5	Lbs	3,3
Max. mix per cycle	Kg	2,5	Lbs	5,5
Volume cylinder with mixer	Liters	5,7	Quarts	6
Volume cylinder without mixer	Liters	6,1	Quarts	6,5
Stirrer speed	3 speeds from 30 to 110 RPM			
Mixer speed	8 speeds from 20 to 240 RPM			
Max power	kw	5,3	Hp	7,1
Voltage	230 Volt / 60 Hz / 3 phase			
Running Amps	Amp 17,7			
Breaker size	Amp 30			
Stirrer motor	kw	0,22	Hp	0,3
Drive motor	kw	1,1	Hp	1,5
Compressor power	kw	1,2	Hp	1,6
Compressor power	BTU/h 3200			
Freon R404A	Gr	2100	Oz	74,1
Refrigeration condensation	Air			
Crate dimensions	cm	100X63X105	inches	39,4x24,2x41,3
Crate weight	kg	180	lbs	396



Warranty: valid for the North American Continent (Canada, USA)
Extension: 12 months parts (with check list and warranty signed and mailed)
5 years compressor with registration on warranty.bravonorthamerica.com



Bravo North America Inc. Office & Showroom, 810 Tyvola Road, Suite 130, Charlotte, NC 28217
tel. +1 980 237 2474 bravonorthamerica.com info@bravonorthamerica.com

Trittico Executive 305

Combined machine with ionic-system and double inverter for pastry products, chocolate, savoury food and gelato water cooled

Model:
 Quantity:
 Project:
 Company:
 Contact:
 Dealer ID:

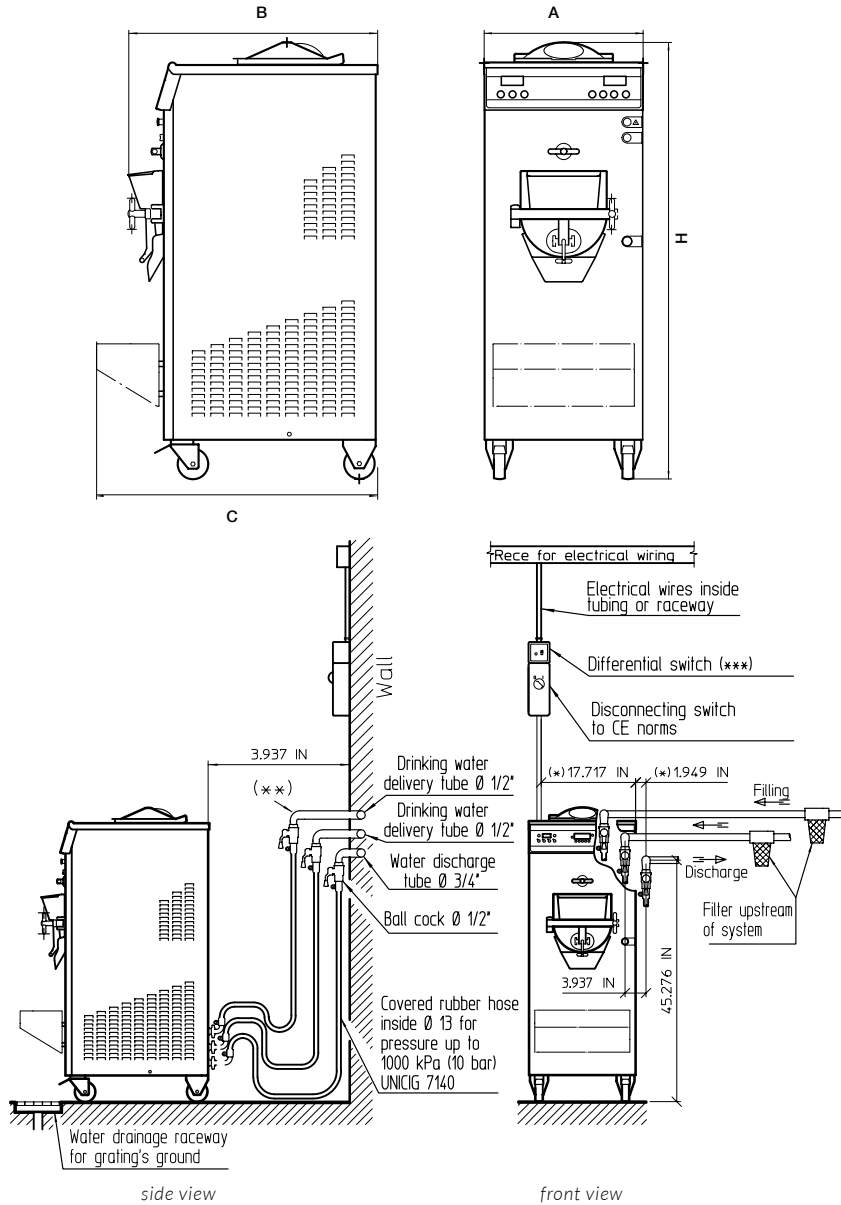

(*) Even if the machine models vary, the water and electricity connection positions are always the same, i.e. on the LEFT side of the machine.
 (**) The cock is higher for illustration requirements. In really it must be placed side by side with the other.
 (***) 300 mA (ABB serie K)



Warranty: valid for the North American Continent (Canada, USA)
 Extension: 12 months parts (with check list and warranty signed and mailed)
 5 years compressor with registration on warranty.bravonorthamerica.com

Width (A)	cm	51	inches	20,1
Depth (B)	cm	80	inches	31,5
Depth with base (C)	cm	87,5	inches	34,4
Height (H)	cm	140	inches	55,1
Weight	kg	256	lbs	564
Frame type	floor model			
Outer panels	stainless steel			
Capacity per cycle	Liters	5	Gal	1,32
Max. hourly production for gelato	Liters	30	Gal	7,92
Max. hourly production for pastry	based on the product that has to be produced			
Min. mix per cycle	Kg	2	Lbs	4,4
Max. mix per cycle	Kg	4	Lbs	8,8
Volume cylinder with mixer	Liters	8,93	Quarts	9,43
Volume cylinder without mixer	Liters	9,46	Quarts	10
Stirrer speed	3 speeds from 30 to 80 RPM			
Mixer speed	8 speeds from 20 to 300 RPM			
Max power	kw	5,7	Hp	7,7
Voltage	230 Volt / 60 Hz / 3 phase			
Running Amps	Amp 19,4			
Breaker size	Amp 30			
Stirrer motor	kw	0,22	Hp	0,3
Drive motor	kw	2,2 - 1,5	Hp	3 - 2
Compressor power	kw	1,3	Hp	1,75
Compressor power	BTU/h 4688			
Freon R404A	Gr	1150	Oz	40,5
Refrigeration condensation	Water			
Water connection	cm	1,27	inches	1/2
Min. water pressure	bar	1,5	psi	20
Max. water pressure	bar	3	psi	40
Crate dimensions	cm	101x69x172	inches	39,7x27,1x70
Crate weight	kg	360	lbs	793



Bravo North America Inc. Office & Showroom, 810 Tyvola Road, Suite 130, Charlotte, NC 28217
 tel. +1 980 237 2474 bravonorthamerica.com info@bravonorthamerica.com

Trittico Executive 305

Combined machine with ionic-system and double inverter for pastry products, chocolate, savoury food and gelato
air cooled

Model:
Quantity:
Project:
Company:
Contact:
Dealer ID:

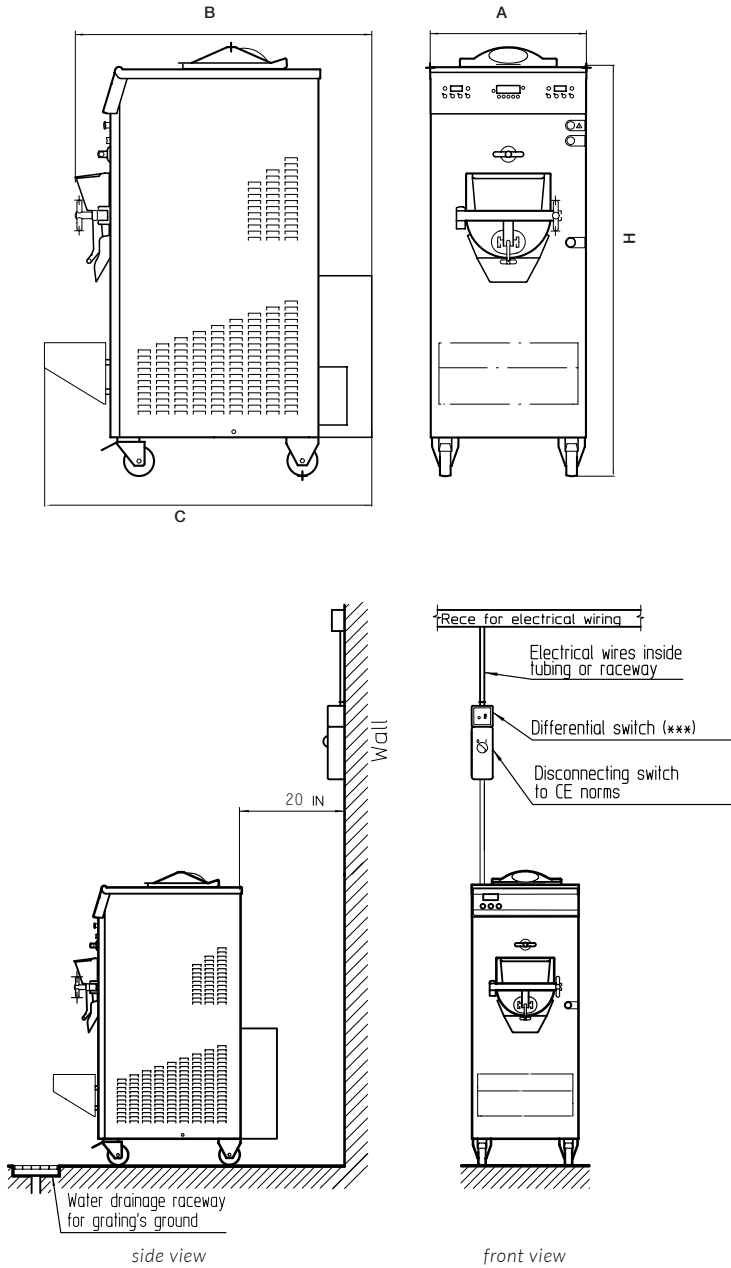

(***) 300 mA (ABB serie K)

Width (A)	cm	51	inches	20,1
Depth (B)	cm	97	inches	38,2
Depth with base (C)	cm	107	inches	40,7
Height (H)	cm	140	inches	55,1
Weight	kg	256	lbs	564
Frame type	floor model			
Outer panels	stainless steel			
Capacity per cycle	Liters	5	Gal	1,32
Max. hourly production for gelato	Liters	30	Gal	7,92
Max. hourly production for pastry	based on the product that has to be produced			
Min. mix per cycle	Kg	2	Lbs	4,4
Max. mix per cycle	Kg	4	Lbs	8,8
Volume cylinder with mixer	Liters	8,93	Quarts	9,43
Volume cylinder without mixer	Liters	9,46	Quarts	10
Stirrer speed	3 speeds from 30 to 80 RPM			
Mixer speed	8 speeds from 20 to 300 RPM			
Max power	kw	5,7	Hp	7,7
Voltage	230 Volt / 60 Hz / 3 phase			
Running Amps	Amp 19,4			
Breaker size	Amp 30			
Stirrer motor	kw	0,22	Hp	0,3
Drive motor	kw	2,2 - 1,5	Hp	3 - 2
Compressor power	kw	1,3	Hp	1,75
Compressor power	BTU/h 4688			
Freon R404A	Gr	2100	Oz	74,1
Refrigeration condensation	Air			
Crate dimensions	cm	109x69x172	inches	42,9x27,1x67,7
Crate weight	kg	370	lbs	813



Warranty: valid for the North American Continent (Canada, USA)
Extension: 12 months parts (with check list and warranty signed and mailed)
5 years compressor with registration on warranty.bravonorthamerica.com



Bravo North America Inc. Office & Showroom, 810 Tyvola Road, Suite 130, Charlotte, NC 28217
tel. +1 980 237 2474 bravonorthamerica.com info@bravonorthamerica.com

Trittico Executive 457

Combined machine with ionic-system and double inverter for pastry products, chocolate, savoury food and gelato water cooled

Model:
 Quantity:
 Project:
 Company:
 Contact:
 Dealer ID:

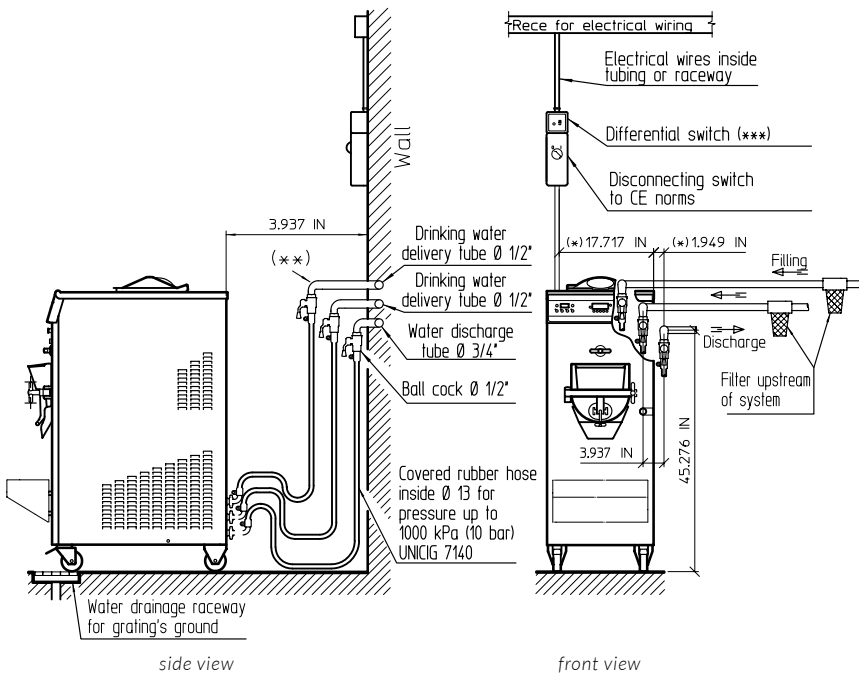
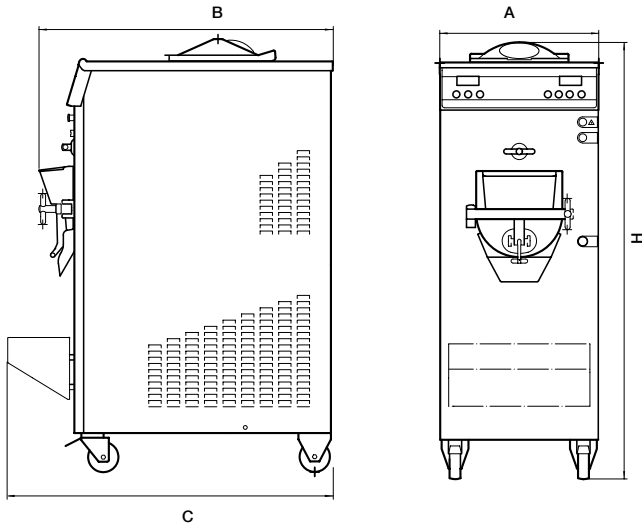

(*) Even if the machine models vary, the water and electricity connection positions are always the same, i.e. on the LEFT side of the machine.
 (**) The cock is higher for illustration requirements.
 In really it must be placed side by side with the other.
 (***) 300 mA (ABB serie K)

Width (A)	cm	51	inches	20,1
Depth (B)	cm	95	inches	37,4
Depth with base (C)	cm	102,5	inches	40,4
Height (H)	cm	140	inches	55,1
Weight	kg	309	lbs	681
Frame type	floor model			
Outer panels	stainless steel			
Capacity per cycle	Liters	7	Gal	1,84
Max. hourly production for gelato	Liters	45	Gal	11,88
Max. hourly production for pastry	based on the product that has to be produced			
Min. mix per cycle	Kg	2,5	Lbs	5,5
Max. mix per cycle	Kg	5,5	Lbs	12,1
Volume cylinder with mixer	Liters	11,78	Quarts	12,45
Volume cylinder without mixer	Liters	12,42	Quarts	13,12
Stirrer speed	3 speeds from 30 to 80 RPM			
Mixer speed	8 speeds from 20 to 300 RPM			
Max power	kw	6,3	Hp	8,4
Voltage	230 Volt / 60 Hz / 3 phase			
Running Amps	Amp 21			
Breaker size	Amp 30			
Stirrer motor	kw	0,22	Hp	0,3
Drive motor	kw	3,3 - 2,2	Hp	4,5 - 3
Compressor power	kw	2,8	Hp	3,75
Compressor power	BTU/h 9349			
Freon R404A	Gr	1200	Oz	42
Refrigeration condensation	Water			
Water connection	cm	1,27	inches	1/2
Min. water pressure	bar	1,5	psi	20
Max. water pressure	bar	3	psi	40
Crate dimensions	cm	110x80x172	inches	42,9x29x67,7
Crate weight	kg	380	lbs	850



Warranty: valid for the North American Continent (Canada, USA)
 Extension: 12 months parts (with check list and warranty signed and mailed)
 5 years compressor with registration on warranty.bravonorthamerica.com



Bravo North America Inc. Office & Showroom, 810 Tyvola Road, Suite 130, Charlotte, NC 28217
 tel. +1 980 237 2474 bravonorthamerica.com info@bravonorthamerica.com

Trittico Executive 457

Combined machine with ionic-system and double inverter for pastry products, chocolate, savoury food and gelato
air cooled

Model:
Quantity:
Project:
Company:
Contact:
Dealer ID:

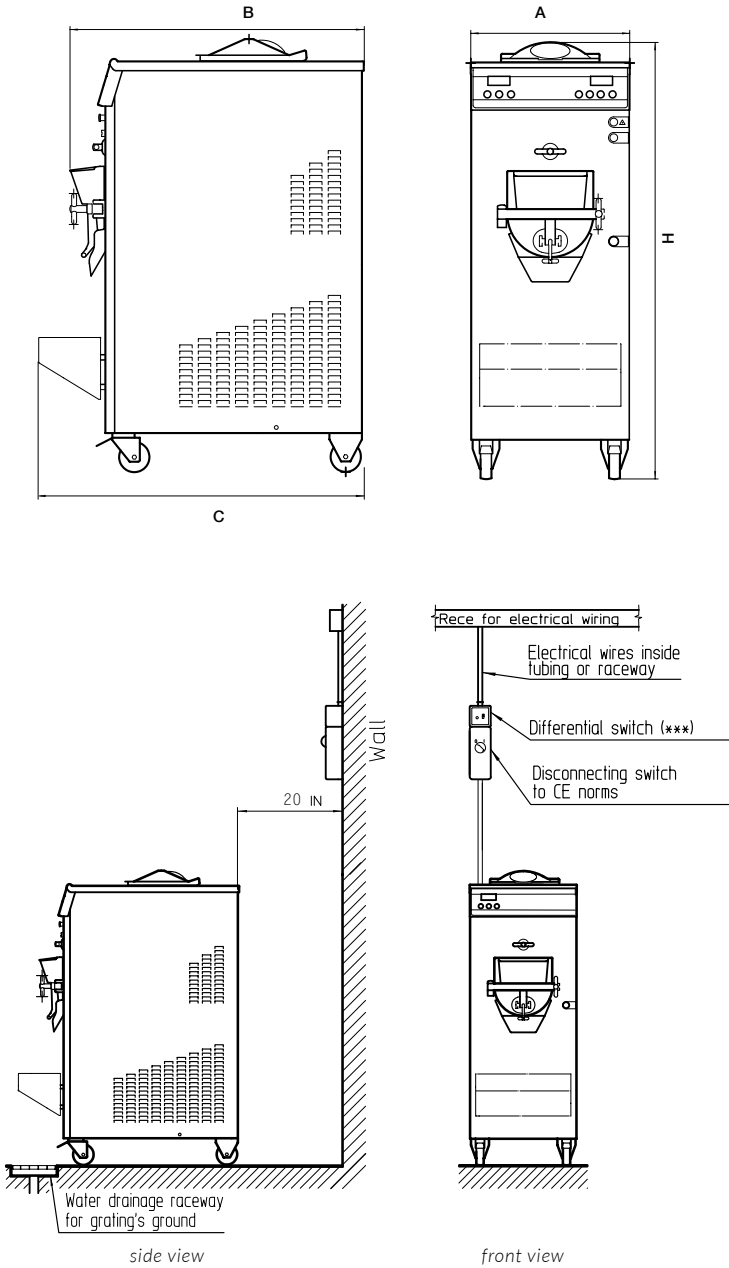

(***) 300 mA (ABB serie K)

Width (A)	cm	61	inches	24
Depth (B)	cm	95	inches	37,4
Depth with base (C)	cm	102,5	inches	40,4
Height (H)	cm	140	inches	55,1
Weight	kg	295	lbs	642
Frame type	floor model			
Outer panels	stainless steel			
Capacity per cycle	Liters	7	Gal	1,84
Max. hourly production for gelato	Liters	45	Gal	11,88
Max. hourly production for pastry	based on the product that has to be produced			
Min. mix per cycle	Kg	2,5	Lbs	5,5
Max. mix per cycle	Kg	5,5	Lbs	12,1
Volume cylinder with mixer	Liters	11,78	Quarts	12,45
Volume cylinder without mixer	Liters	12,42	Quarts	13,12
Stirrer speed	3 speeds from 30 to 80 RPM			
Mixer speed	8 speeds from 20 to 300 RPM			
Max power	kw	6,5	Hp	8,7
Voltage	230 Volt / 60 Hz / 3 phase			
Running Amps	Amp 21			
Breaker size	Amp 30			
Stirrer motor	kw	0,22	Hp	0,3
Drive motor	kw	3,3 - 2,2	Hp	4,5 - 3
Compressor power	kw	2,8	Hp	3,75
Compressor power	BTU/h 9349			
Freon R404A	Gr	1150	Oz	40,5
Refrigeration condensation	Air			
Crate dimensions	cm	110x80x172	inches	42,9x29x67,7
Crate weight	kg	390	lbs	860



Warranty: valid for the North American Continent (Canada, USA)
Extension: 12 months parts (with check list and warranty signed and mailed)
5 years compressor with registration on warranty.bravonorthamerica.com



Bravo North America Inc. Office & Showroom, 810 Tyvola Road, Suite 130, Charlotte, NC 28217
tel. +1 980 237 2474 bravonorthamerica.com info@bravonorthamerica.com

Trittico Executive 610

Combined machine with ionic-system and double inverter for pastry products, chocolate, savoury food and gelato
water cooled

Model:
Quantity:
Project:
Company:
Contact:
Dealer ID:

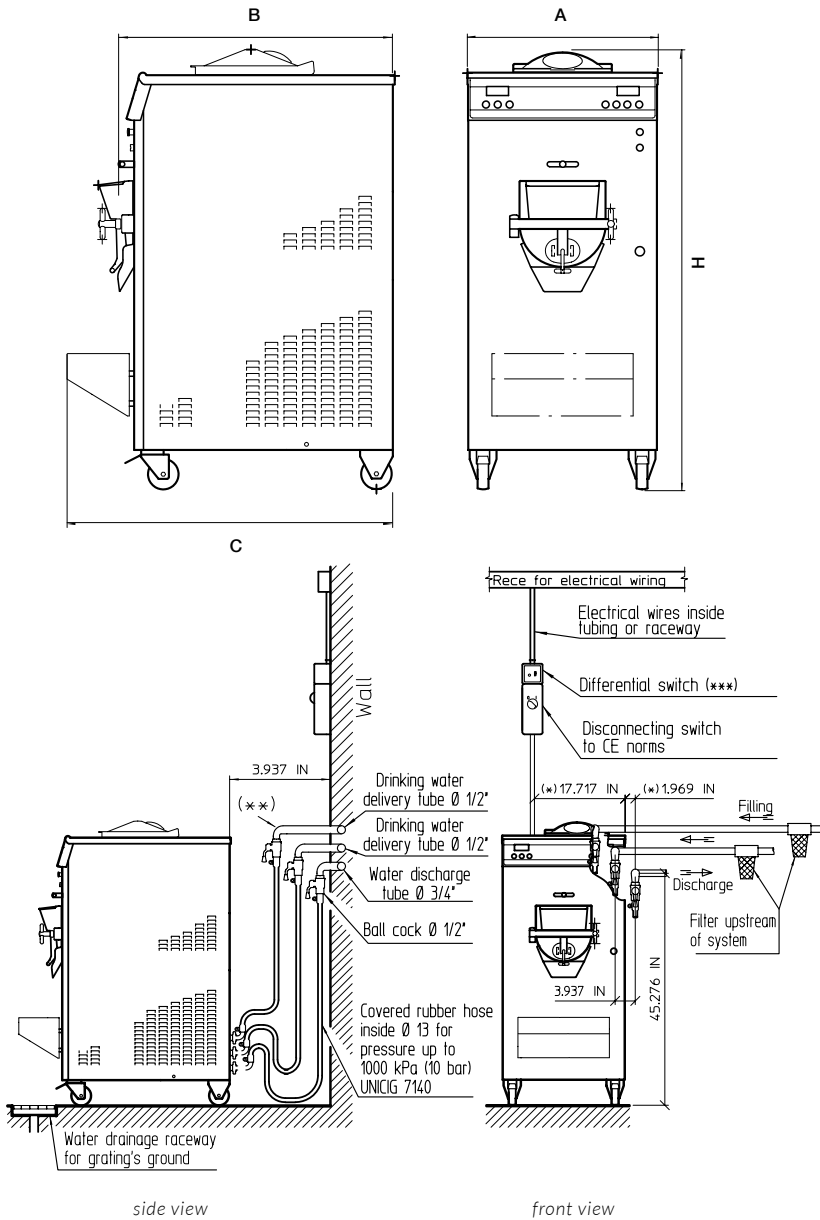

(*) Even if the machine models vary, the water and electricity connection positions are always the same, i.e. on the LEFT side of the machine.
(**) Cocks are in vertical only for illustration purposes.
(***) 30 mA (ABB serie C).



Warranty: valid for the North American Continent (Canada, USA)
Extension: 12 months parts (with check list and warranty signed and mailed)
5 years compressor with registration on warranty.bravonorthamerica.com

Width (A)	cm	61	inches	24
Depth (B)	cm	95	inches	37,4
Depth with base (C)	cm	102,5	inches	40,4
Height (H)	cm	141	inches	55,5
Weight	kg	346	lbs	763
Frame type	floor model			
Outer panels	stainless steel			
Capacity per cycle	Liters	10	Gal	2,64
Max. hourly production for gelato	Liters	60	Gal	15,85
Max. hourly production for pastry	based on the product that has to be produced			
Min. mix per cycle	Kg	4	Lbs	8,8
Max. mix per cycle	Kg	8	Lbs	17,6
Volume cylinder with mixer	Liters	15,83	Quarts	16,73
Volume cylinder without mixer	Liters	16,64	Quarts	17,58
Stirrer speed	3 speeds from 30 to 80 RPM			
Mixer speed	8 speeds from 20 to 300 RPM			
Max power	kw	9	Hp	11,9
Voltage	230 Volt / 60 Hz / 3 phase			
Running Amps	Amp 30,1			
Breaker size	Amp 60			
Stirrer motor	kw	0,22	Hp	0,3
Drive motor	kw	4-2,6	Hp	5,4-3,5
Compressor power	kw	2,8	Hp	3,75
Compressor power	BTU/h 9349			
Freon R404A	Gr	2000	Oz	70,5
Refrigeration condensation	Water			
Water connection	cm	1,27	inches	1/2
Min. water pressure	bar	1,5	psi	20
Max. water pressure	bar	3	psi	40
Crate dimensions	cm	110x80x172	inches	42,9x29x67,7
Crate weight	kg	437	lbs	965



Bravo North America Inc. Office & Showroom, 810 Tyvola Road, Suite 130, Charlotte, NC 28217
tel. +1 980 237 2474 bravonorthamerica.com info@bravonorthamerica.com

Trittico Executive 1020

Combined machine with ionic-system and double inverter for pastry products, chocolate, savoury food and gelato water cooled

Model:
 Quantity:
 Project:
 Company:
 Contact:
 Dealer ID:

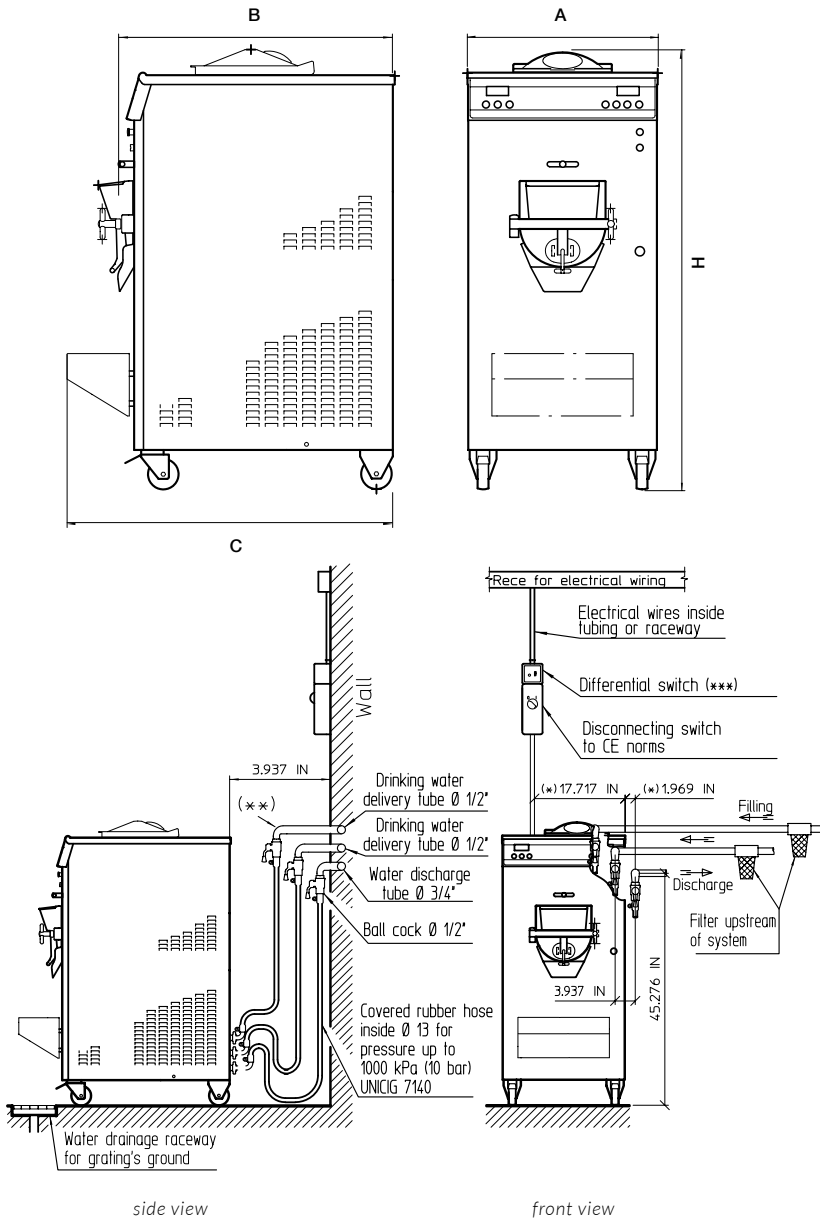

(*) Even if the machine models vary, the water and electricity connection positions are always the same, i.e. on the LEFT side of the machine.
 (**) Cocks are in vertical only for illustration purposes.
 (***) 30 mA (ABB serie C).



Warranty: valid for the North American Continent (Canada, USA)
 Extension: 12 months parts (with check list and warranty signed and mailed)
 5 years compressor with registration on warranty.bravonorthamerica.com

Width (A)	cm	61	inches	24
Depth (B)	cm	115	inches	45,3
Depth with base (C)	cm	122,5	inches	48,2
Height (H)	cm	144	inches	56,7
Weight	kg	510	lbs	1124
Frame type	floor model			
Outer panels	stainless steel			
Capacity per cycle	Liters	20	Gal	5,28
Max. hourly production for gelato	Liters	120	Gal	31,7
Max. hourly production for pastry	based on the product that has to be produced			
Min. mix per cycle	Kg	8	Lbs	17,6
Max. mix per cycle	Kg	16	Lbs	35,3
Volume cylinder with mixer	Liters	26,05	Gal	27,53
Volume cylinder without mixer	Liters	27,63	Gal	29,20
Stirrer speed	3 speeds from 30 to 80 RPM			
Mixer speed	8 speeds from 20 to 300 RPM			
Max power	kw	17,3	Hp	23,2
Voltage	230 Volt / 60 Hz / 3 phase			
Running Amps	Amp 61,2			
Breaker size	Amp100			
Stirrer motor	kw	0,22	Hp	0,3
Drive motor	kw	7,5 - 4,8	Hp	10 - 6,4
Compressor power	kw	5,5	Hp	7,4
Compressor power	BTU/h 13624			
Freon R404A	Gr	3000	Oz	105,8
Refrigeration condensation	Water			
Water connection	cm	1,27	inches	1/2
Min. water pressure	bar	1,5	psi	20
Max. water pressure	bar	3	psi	40
Crate dimensions	cm	132X79X185	inches	51,9x31x72,9
Crate weight	kg	610	lbs	1344



Bravo North America Inc. Office & Showroom, 810 Tyvola Road, Suite 130, Charlotte, NC 28217
 tel. +1 980 237 2474 bravonorthamerica.com info@bravonorthamerica.com