

Linium 305

Poly and Shrink Film Rotary Head Horizontal Wrapper

High-Speed Packaging with Shrink or Polyethylene Films



Optional Accessories and SK200 Shrink Tunnel Shown



Linium 305 Rotary Cutting Head



PRODUCTS PACKAGED:

- Single piece items
- Multi-packs
- Trays
- Retail packages
- Hardware
- Pharmaceuticals
- Paper
- Food
- Confection
- Almost any regular-shaped product within the machine size limits

PACKAGE:

- End seal: Continuous bead seal and cutoff
- Longitudinal seal: Lap seal with static seal, bead seal or combination seal

PACKAGING MATERIAL

- Polyolefin
- Polyethylene
- PVC
- Blended polypropylene
- Polyethylene

CONSTRUCTION:

- Steel plate frame construction
- Cantilevered product track (infeed, vacuum belt and cutting head)
- Servo driven

OPERATION:

Film from a roll is formed around the products. A bottom lap seal is formed (static and/or hot shoe) providing impeccable package appearance and producing no scrap material. A vacuum conveyor pulls the film and carries product to the rotary cutting head. The rotary cutting head then produces a bead type end-seal and cuts packages apart.

Poly and Shrink Film Rotary Head Horizontal Wrapper

LINIUM 305 MECHANICAL DIMENSIONS:

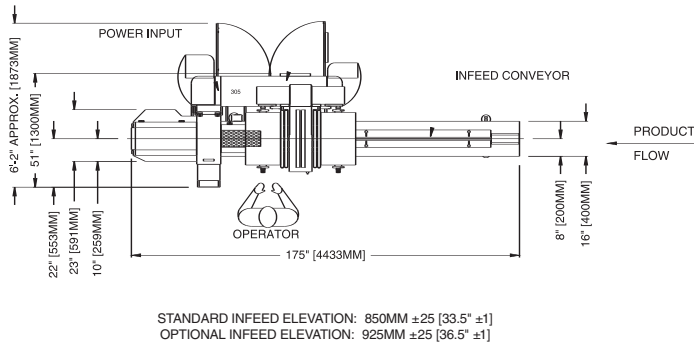

OPERATION SCHEMATIC:

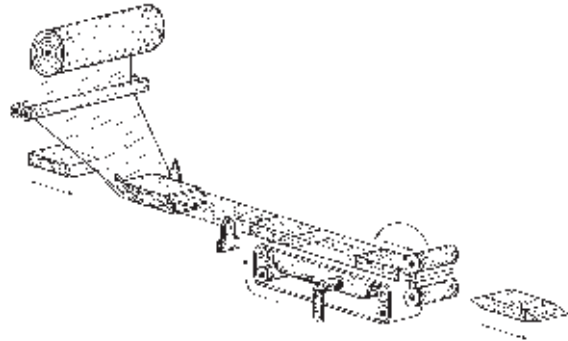

SPECIFICATIONS:

OUTPUT: Up to 150 packages per minute (1up)
 Up to 300 packages per minute (2up)
 Up to 50m/min (1,960"/min) film speed
Product and film characteristics may affect machine output.

SIZE RANGE:

Package cutoff length: 115mm-565mm (4.5"-22.25")
 Product width: 75mm-250mm (3.0"-9.8")
 Maximum product height: 115mm (4.5")
 End seal knife width: 250mm (9.8")

Options may be required.

Maximums may not be possible in combination.

WEB DIMENSIONS:

Maximum width: 600mm (23.6")
 Maximum reel diameter: 350mm (13.75")
 Core diameter: 75mm (3.0")

CONNECTIONS:

Voltage: 230V, 50/60hz, 3 phase standard
 Power usage: 15 amp, 5 KVA
 Air: 80 PSI (5.5 bar), 0.2 CFM

STANDARD FEATURES:

- Dobby 1up rotary end seal unit
- 2m (6.5') infeed conveyor with snap-in pushers
- 1 film spindle and power feed roll
- Vacuum conveyor film feed
- Static lap seal device
- 3 servo motors (infeed, vacuum belt conveyor, cutting head)
- Wing style former

OPTIONS:

- Second film spindle
- Film registration eye
- Combination hot shoe and static lap seal device, and more
- Dobby shrink tunnels for perfect shrink packages
- Automatic feeders – inline, crossbelt, hoppers, parallel belt and product distribution solutions

The machinery shown herein may have had guards removed for illustrative purposes. NEVER operate this machinery without all guards in place and all safety features in original working condition. ALWAYS refer to the operator's manual, or contact Dobby, for additional information. Specifications subject to change without notice.

Dobby Inc.

A Bosch Packaging Technology Company
 869 South Knowles Avenue
 New Richmond, WI 54017 USA
 Phone (715) 246-6511
 Fax (715) 246-6539
 sales@dobby.com
 www.dobby.com

Dobby Inc.

BOSCH