



**SAVAGE
BROS. CO.**
S I N C E 1 8 5 5

1825 Greenleaf Avenue
Elk Grove Village, IL 60007-5501 USA



Phone: 847-981-3000
USA Fax: 800-2-SAVAGE
World Fax: +847-981-3010

E-mail: info@savagebros.com
Web: www.savagebros.com

A 21st Century Company . . . with 19th Century Craftsmanship

FireMixer-14 TABLE-TOP COOKER-MIXER

**WITH PLC TOUCH-SCREEN TEMPERATURE & FUNCTION CONTROL
AND WATER COOLING FEATURE!**

NEW 'SMART' PLC Touch-Screen control panel makes monitoring and controlling your processing easy and fun! Ability to monitor and control temperature of both product AND skin of kettle for no-burn processing. Unique cooling feature permits flushing of heat out of cooker at the end of the cook by flowing tap water through it, giving you time to remove the product without temperature overshoot.

**Fudge
Caramel
Toffee
Brittle
Creams
Hard Candy
And More!**



**Ideal for
R&D Labs!**

- All Stainless Steel sanitary construction
- Optimum cooking capacity of 20 lb / 9 kg batches
- Cycle time for full batch of most candies is 20 to 60 minutes
- 18"x20" footprint / 24"x30" with controls
- 3KW / Multi-Voltage 208-240VAC / Single Phase / 50-60Hz / 16 Amps
- Self-regulates to your facility voltage!
- Requires cold water source and drain for water-flush feature

PLC Touch Screen Controls



Above is SAMPLE Screen display.

In this example, the product is being cooked at a low temperature. Actual 'Cook To' temperature can be set much higher for other products.

Maximum Cooking Temperature 450°F

- Spring-Loaded Scraper Agitator
- Bottom-drive agitator-28 RPM @ 60 Hz
- Lid-Off Agitator Safety Stop (On Export Models)
- Remove agitator without tools for easy cleaning
- Easy-Pull handle for one-hand pouring of product
- Locks in semi-tilted position for enhanced mixing action while cooking
- Water-Flush feature allows cooling of cooker after set-point temperature is reached - immediately stops cook and prevents overshoot
- Recipe and degree of tilt determines final batch size and cook time
- PLC programmable for Fahrenheit or Celsius scale
- PLC program can be upgraded for future enhancements

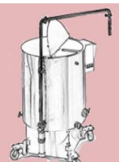
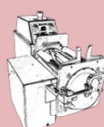

Gas & Electric Stoves ♦ Copper & Stainless Kettles ♦ FireMixer Cooker-Mixers ♦ Carousel Line ♦ Bowl & Kettle LIFT/Truks ♦ Cooling Tables ♦ Chocolate Tempering ♦ Depositing & Transfer Systems

Product # 2410 2015

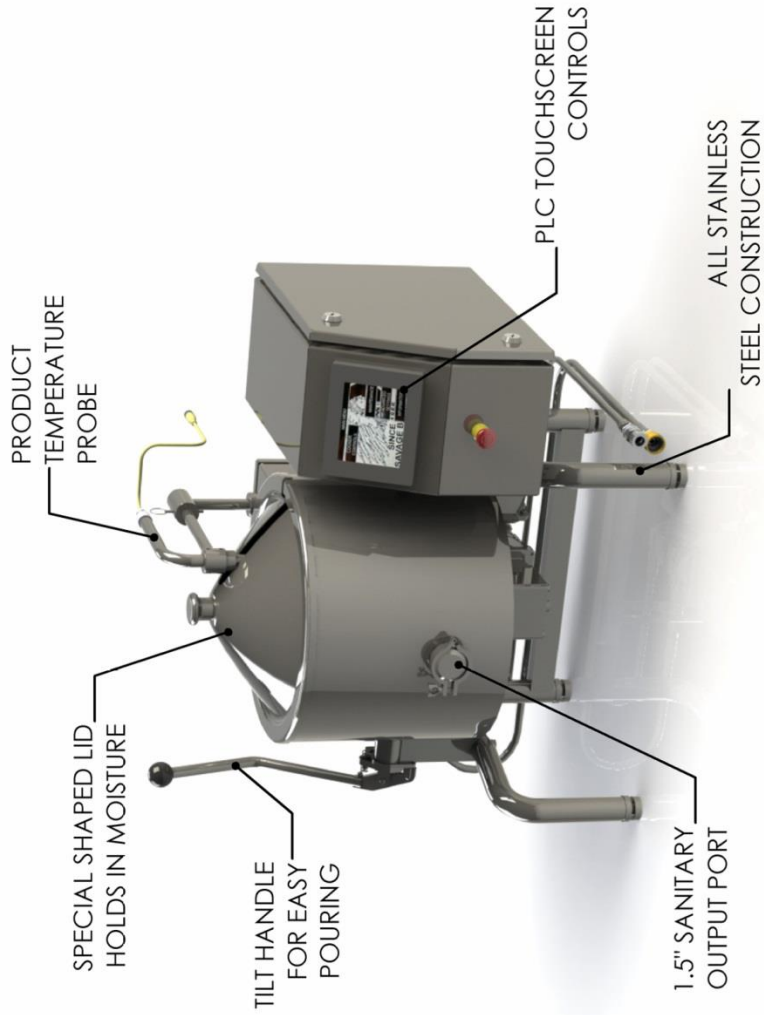
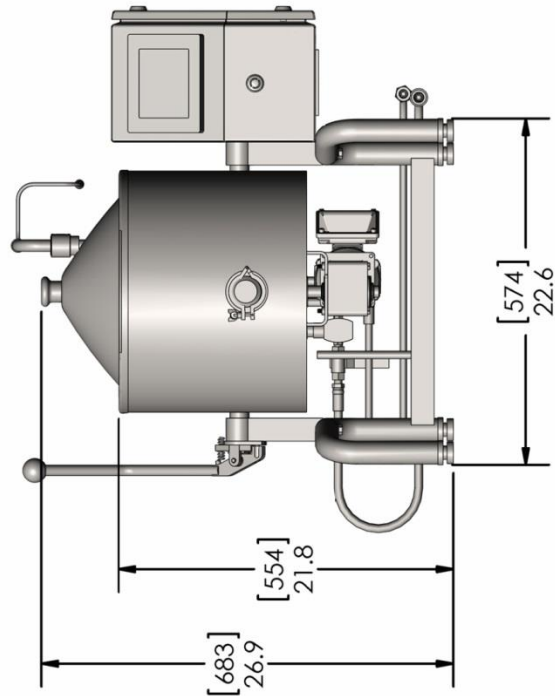
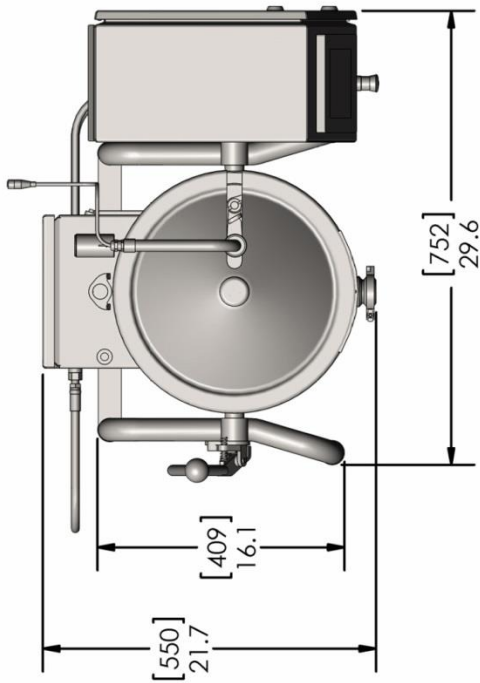

QUOTATION

FOR QUOTATION PURPOSES ONLY

ALL DESIGNS SUBJECT TO FINAL APPROVAL BEFORE MANUFACTURE

DO NOT SCALE DRAWING

SAVAGE BROS. CO.
 1125 W. Lunt Ave
 Elk Grove Village, IL 60007 U.S.A.
 Phone: (847) 981 - 3000
 USA Fax: (800) 2 - SAVAGE
 World Fax: (847) 981 - 3010



FIREMIXERS
 FIREMIXER-14

DWG. NUM.
 2410

DES. BY	DRN. BY	DATE	SCALE	SHEET
ML	BW	1/27/2004	SCALE: 1:12	3 OF 3

UNITS: $\frac{[mm]}{IN}$