



Controll

Wrap-around reel-fed labelling



High flexibility with wrap-around labelling

When it comes to decorating containers with wrap-around, reel-fed labels, the Controll has been setting the benchmark for many years now. The machine has been designed as rotary machine and is equipped with a precisely operating labelling station. With regard to efficiency, accuracy and speed, the Controll absolutely takes a leading position.

At a glance

- Wrap-around labelling for round or specially-shaped containers
- Precise container positioning using centring bells and centring plates
- Operation by means of individual transponders for quick access to the user interface
- Use of remote maintenance possible as an option





Method of operation

1. A feed roller, the speed of which is adjusted to suit the label length, continually pulls the label film from the reel. The label film guider, which is installed as standard, makes sure that the label film is pulled straight.
2. In the cutting unit, the labels are precisely cut while a computer and servo motor provide an exact cut-off point.
3. Two narrow strips of hotmelt, which are applied by a heated glue roller to the leading and trailing label edges, glue the labels together.
4. As the container is rotating while the label is being applied, the label is stretched to fit smoothly. When the trailing edge is glued down, the secure bond is complete.

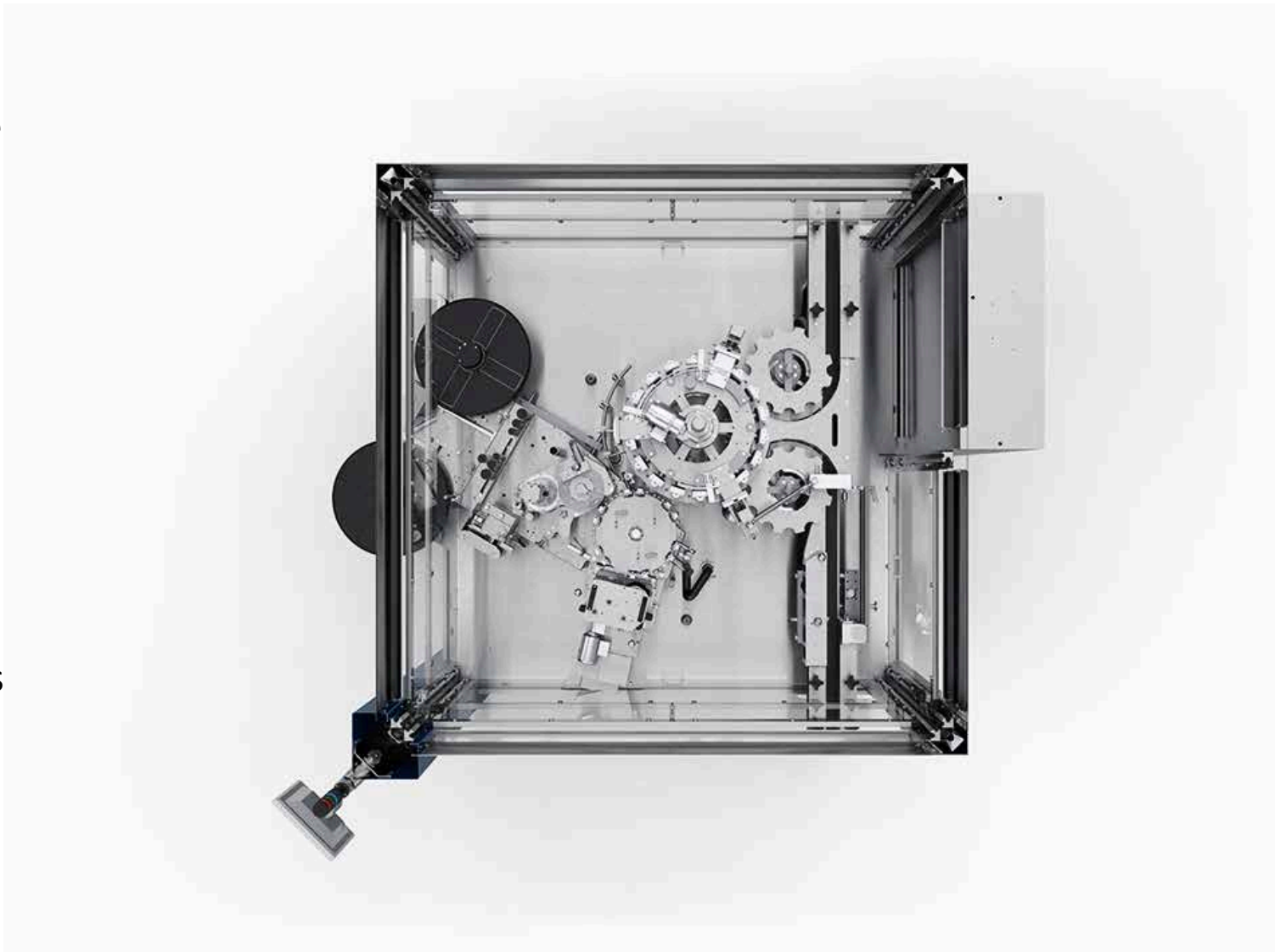



Two variants for wrap-around labelling

Controll with ED labelling station

- Processes 3,000 to 60,000 containers per hour, with only one labelling station, depending on the label length
- Variable equipment of the labelling station for processing longer labels as well
- Integrated servo drive technology for reel holder, feed roller, cutting unit, vacuum-grip cylinder and hotmelt unit

Controll standard version

- Processes 3,000 to 36,000 containers per hour, with one labelling station, depending on the label length
- Servo drive in the label feed system



ED = Ergonomic Design



Design features

Controll ED labelling station

- Labelling station design according to ergonomic criteria
- Electronic cutting unit with servo-controlled drives
- Central height adjustment system for the film support
- Automatic reel splicing unit
- Controlled glue application with low glue consumption thanks to the newly developed "Gravure glue application" system
- Insulated glue bowl with new glue pump
- Incline adjustment for overlap correction
- Granted cutter service life for 120 million cuts and cutter replacement within one minute

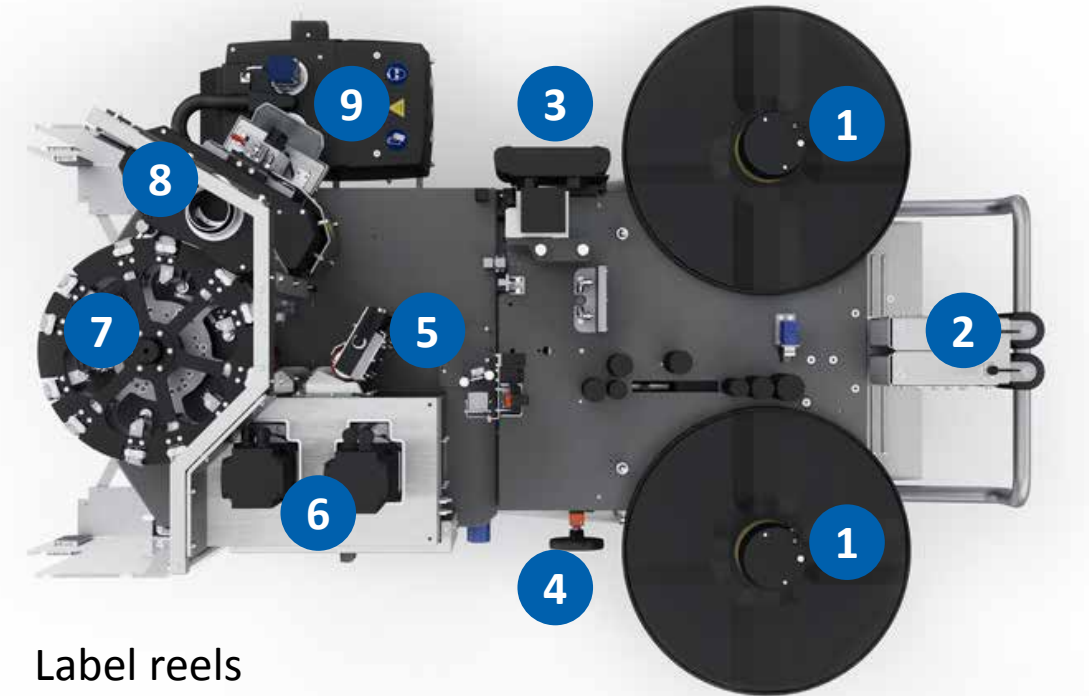

1. Label reels
2. Automatic splicing unit
3. Label film guider
4. Incline adjustment system
5. Feed roller
6. Cutting unit
7. Vacuum-grip cylinder
8. Hotmelt gluing unit
9. Glue bowl



Design features

Controll standard version

- Computer-controlled servo motor drives the feed roller
- Complete cutting unit can be removed for maintenance
- Electronic cap inspection and gap detection at the machine infeed
- Single-hand fasteners for quick change-over of the centring bells and container plates
- Low-cost labelling station with fixed range of label length
- Central lubrication points
- Automatic reel splicing function as an option

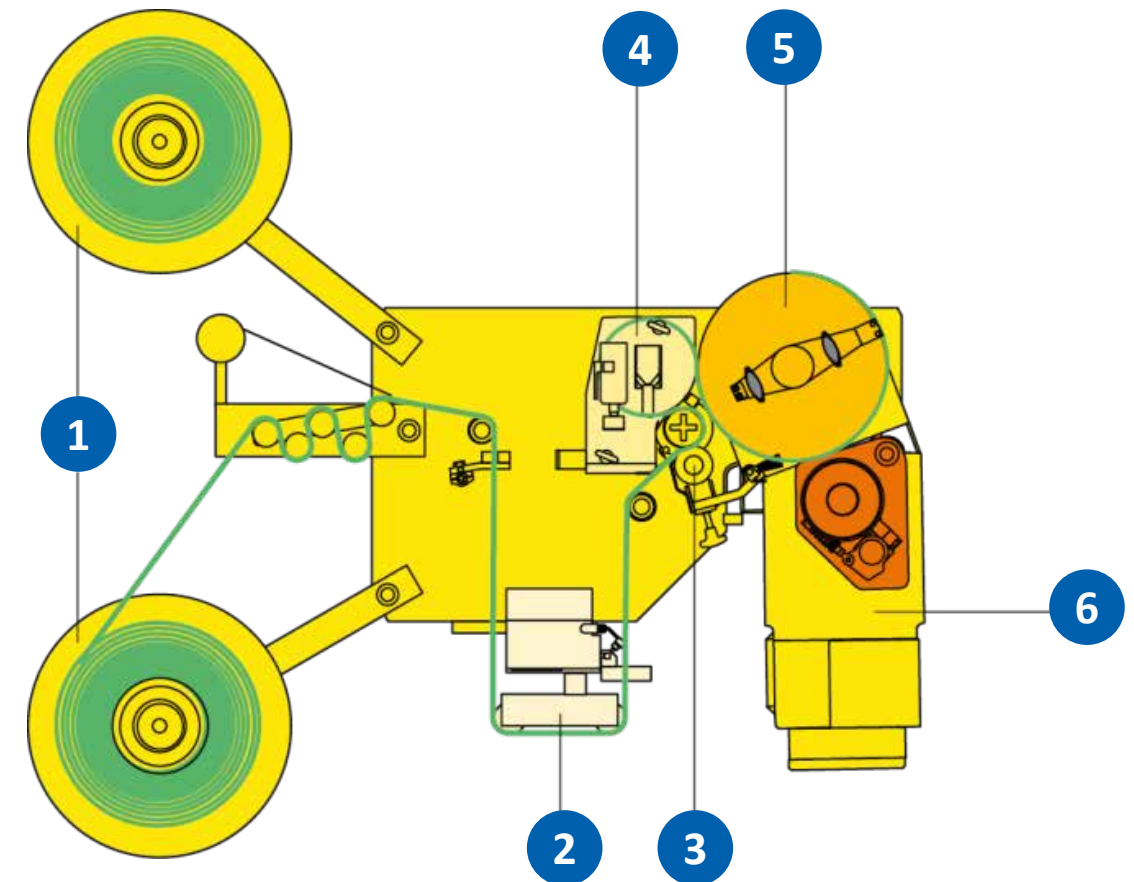

1. Label reels
2. Label film guider
3. Feed roller
4. Cutting unit
5. Vacuum-grip cylinder
6. Hotmelt gluing unit



Additional equipment

Labelling of empty containers

- Empty containers are stabilised with compressed air prior to filling
- Employment of special centring bells
- Neck-handling starwheels
- Motorised height-adjustable container table



Multifunctional clamping starwheel

- Application as infeed, discharge, or distribution starwheel
- No curved guide required
- The starwheels can be used for several container types with diameters which can differ by up to 20 mm
- Use as a rejection system after label inspection possible





System upgrades: Multireel C

- Supports four or an optional six label reels (for a label height of 30 – 150 mm millimetres)
- Production duration of up to eight hours, without operator intervention
- Splices label reels automatically without any reduction in output
- Can be retrofitted onto Controll labellers which have already been installed
- Space-saving and ergonomic design
- Output of up to 60,000 containers per hour





System upgrades: Checkmat inspection unit

- Checks if labels have been provided and if they are correct
- Checks the position and orientation of the labels
- Checks printed data, such as best-before dates or product codes, to ensure they are present and correct
- Recognises bar codes
- Checks fill level and container seal
- Rejects faulty containers using a retaining starwheel, clamping starwheel, or pusher





Benefits to you

High labelling precision

The containers are held exactly in place between centring bell and centring plate.

Low glue consumption

Only two narrow strips of hotmelt are required for labelling, one at the leading end and the other one at the trailing end of the label.

High performance

The different Controll designs allow for precise labelling from the low to the highest output range.

User friendliness

The Controll features ease of access and ease of operation.

Time savings

Only short change-over times needed when changing container or label type.

Less work for the operators

The Multireel C reel-storage magazine which is additionally available enables the Controll to work entirely autonomously for up to eight hours.

Flexibility for the future

The Controll can still be retrofitted or converted, even after many years of service.



Certified ecological efficiency: machines with enviro certification

At KRONES, the blue enviro label stands for excellent ecological efficiency. Products that bear the enviro label have proven in an objective test procedure that they efficiently use energy and media, and that they produce in an environmentally-friendly way. The requirements are defined by the EME standard that has been developed by the TÜV SÜD (technical inspection authority) for assessing production plants. The enviro test procedure has also been certified by TÜV SÜD as an independent expert. Therefore, you can be sure that an enviro label stands for ecological efficiency.

This is why the Controll with ED labelling station is enviro-classified:

Energy savings:

- Up to 25 percent less energy consumption at the Controll ED labelling station thanks to the split vacuum system
- Insulation of gluing unit and glue bowl for an increased operational safety and reduction of energy consumption

Saving of media:

- Controlled and thus economic glue application thanks to the newly developed "Gravure glue application" system
- Reduced number of lubrication points





Everything from a single source

KIC KRONES adhesives – the all-rounder for a strong grip

Regardless if PET or glass, plastic or paper, labels or packagings – at KIC KRONES, you will find your ideal adhesives for a high-quality product presentation.

KIC KRONES cleaning agents make your machine shine

Only if the production environment is immaculate, can your product be brilliant. KIC KRONES provides you with the optimum cleaning agents and disinfectants for each individual production step.

Lubricants from KIC KRONES for every production step

Whether for gears, chains or central lubrication systems – our greases and oils are true all-round talents. They can reach every lubrication point, protect your line and ensure gentle treatment for your products thanks to their food-grade quality.

KRONES Lifecycle Service – partner for performance

Also after having purchased a new machine, KRONES will take care of your line; the LCS experts are always ready to consult you and translate your goals and wishes into optimal LCS solutions.





Digitalisation



Process
technology



Bottling and
packaging equipment



Intralogistics



Lifecycle
Service

We do more.

 **KRONES**