

delta

3000 LD



www.ilapak.com



PACKAGING MACHINERY

TECHNICAL SPECIFICATIONS

Machine speed	Up to 110 cycles per minute Production output depends on film sealability and product characteristics.
Product dimensions	
LENGTH	Up to 650mm - 25.6" standard Up to 1000mm - 39.0" on request
WIDTH	300mm - 11.8" standard (jaws 345mm - 13.6") 320mm - 12.6" on request (jaws 445mm - 17.3")
HEIGHT	Up to 110mm - 4.3" standard (centre-axle 180) Up to 150mm - 6.0" on request (centre-axle 225) Up to 60mm - 2.4" on request (centre-axle 140)
Film cut-off	Min 100mm - 4.0" / Max 1200mm - 47" Depending on film and product characteristics.
Wrapping materials	Shrink barrier films, laminated, co-extruded and all sealable films
Film reel dimensions	
CORE Ø	76.2mm - 3" standard 152.4mm - 6" on request
OUTER Ø	350mm - 13.8" standard 400mm - 15.7" on request (auto-splicer only)
WIDTH	800mm - 31.5" standard 500mm - 19.7" standard (wet-wipes only) 650mm - 25.6" on request 900mm - 35.4" on request
Film reel max weight	Depending on film reel width, up to 75 kg - 165 lbs
Electronic platform	Industrial PC For USA & Canada, in particular, Allen Bradley platform available.
Power requirement	From 220 to 480 V, 50/60 Hz, 7kVA
Compressed air	6 bar, 200l/min
Machine weight	1400 Kg - 3100 lbs

MAIN STANDARD FEATURES

- Long-dwell sealing head to optimize sealing cycle.
- 4 servo motors to control infeed, rollers, jaws (additional motors with automatic feeders).
- User friendly 10" colour VGA touch screen operator interface with intuitive icons.
- 128 programs (additional memory on request).
- Automatic product size change.
- Integrated temperature control.
- Film tensioning and power unwind system controlled by loadcell.
- Electronic diagnostic on-board.
- No product/ no bag.
- Misplaced product detection system.
- I/O for peripheral units (printer, labelers, gas control, etc.)
- Double film reel mounting with self-centering cones, right hand machine version, 3m long infeed, standard.
- Robust, hygienic, easy to clean design, epoxy powder coating standard or (optional) stainless steel finishing.

Please discuss your needs with our local representative to configure these machines to your product's specific requirements.

ILAPAK is ISO 9001:2000 certified

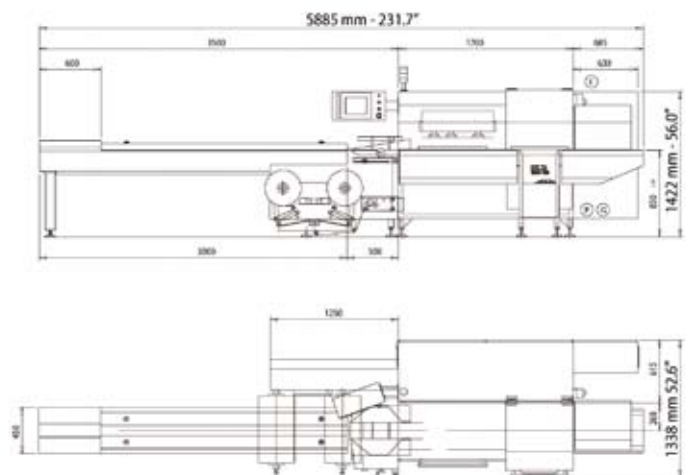

All measurements not specified in inches are given in millimeters.

These specifications are not binding. We reserve that right to change them without prior notice.