

Design

The Maguire Weigh Scale Blender™ (WSB) range of gravimetric batch blenders are for all plastics converting businesses for all types of extrusion applications, and also all Injection and Blow Moulding applications.

The WSB MB Blender consists of 4 removable hoppers fitted with materials dispense valves for metering all materials.

Operation

The Dispense Valves available are as follows;

Corner Valve – high flow slide gate valve designed for poor flowing materials, Pivot Valve – 1.25” Pivot Valve designed to dispense free flowing granules, and Carousel Valve – slower operating dispense valve designed for very small settings between 0.2% to 1.0%.

The standard Micro blender is equipped with 1 Corner Valve for Re grind and 3 Pivot Valves for Natural, Colour and Additives.

The hoppers are mounted above the Weigh Bin with a default 400g batch size.

In normal operation the system tares the weight of the weigh bin and then each material is dispensed - Re grind, Natural, Colour and Additive in sequence, weighing each material after each dispense confirming material required before moving on to the next material.

The complete batch is released into the mixing chamber, and mixed with the previous batch to ensure a homogenous mix.

Material blending is controlled by a level sensor mounted in the upper part of the mix chamber.

When the sensor is covered the blender will not dispense any further batches. The level of material in the mix chamber is critical to good mixing.

As material in the mix chamber is consumed the sensor is uncovered and then the blender then commences the next cycle.



Control

The WSB Controller comes packed with standard features and functions that are unparalleled in the industry.

Key to this is the continuous calibration of materials ensuring accurate dispenses of every material within the blend.

The Controller every dispense updates the gram/second flow rate of each material, ensuring consistent accuracy.

Settings are made easily by either user friendly thumbwheels, or entering settings directly on the keypad.

For special functions these can be easily accessed and set via the password protected keypad.

There is audible alarm and strobe light with silence function, should a batch be incomplete.

Setup and Operation reports can be printed direct to a USB key.

Data is also available allowing remote access and monitoring to download settings and check job progress.

Integration to other control or ERP systems can be made by leading fieldbuses or OPC interfaces.

Dimensions

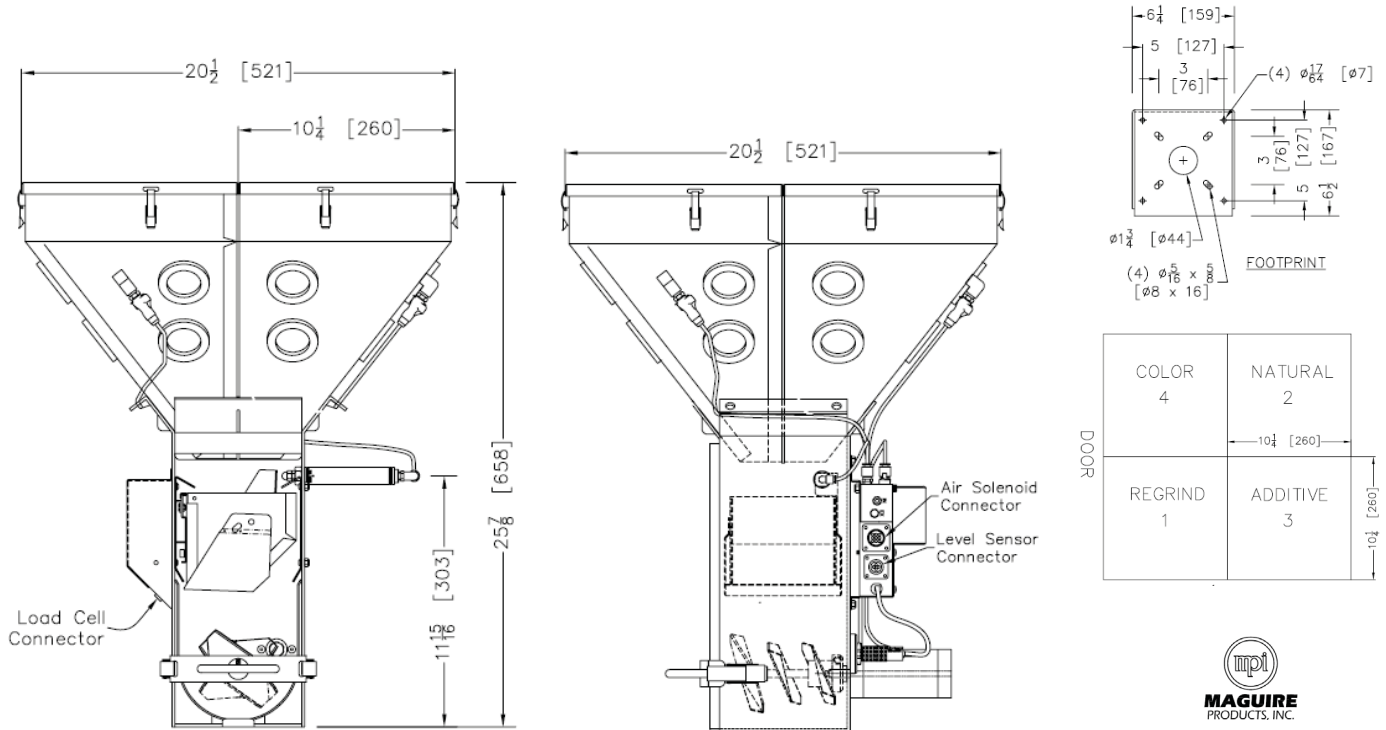

Key Features

- Ideal for small processing machines
- Reduced weight and footprint
- Overall precision of $\pm 0.1\%$ of specified blend
- Compressed air gun for quick cleanout included
- Easy access to all material contact surfaces of the machine including hoppers, weigh bin, and mixing chamber permits rapid colour change without the use of tools
- Proprietary 12-12 microprocessor-control technology monitors and confirms the weight of each ingredient (touch-screen optional).
- Compensation is made when a variation in dispense weight is detected
- Additional standby materials hopper
- Vibration management
- Improved documentation capabilities
- 5 Year Warranty

Technical Data

Model	WSB MB
Maximum Throughput**	40kg/h to 60kg/h 100lb/h to 125lb/h
Number of Materials	4
Material Dispense Systems	1 Corner Valve 3 1.25" Pivot Valves
Weight	45Kg 100lb
Power Supply	110vac - 0.5 Amp 230vac - 0.2 Amp
Operating Air Pressure	3 Bar 40psi
Air Consumption	0.3 m ³ /hr 0.17cfm
** Throughput achieved is influenced by number of materials, how well they flow, vibration and loading consistency - each can effect maximum output of a blender, which in turn effects sizing the correct blender required for an application.	
Shipping Weight	50Kg 110lb
H x W x D	65 x 76 x 55cm 28.5x30.5x22inches
Maguire reserves the right to change technical data without prior notice	