

Comvair[®] Emulsifier

Four great ideas working in one great machine.



Quality Emulsions

Interacting cutting rings produce consistently stable, high quality emulsions from any processing material known to the meat industry. A simple ring change alters the texture of the emulsion from course to superfine. The massaging action extracts salt soluble protein for greater stability.

Low Operating Cost

No expensive knives to replace, no operator adjustments, and a simple design all add up to dramatic savings. Typical operating costs for the Comvair is 2/3 less than competitive emulsifiers.

Exclusive Bone and Metal Trap

The unique built-in trap removes foreign objects before they reach the cutting chamber without interrupting production. Nuts, bolts, bones and bits of plastic are eliminated before the final production stage, thereby reducing rework and damage to equipment.

Low Noise Level

Even with high horsepower models, the decibel level at full production stays low enough to allow normal conversation around the machine.



REISER

Leading the food industry in processing and packaging solutions.



Comvair[®] Emulsifier

The ultimate emulsifier...only from Reiser.

Features

- All stainless steel construction – USDA accepted.
- Easy to assemble and clean with no special tools required.
- Front swivel wheel provides easy maneuverability.
- Production rates of 350 to 1,000 pounds per minute depending on type and texture of product.
- All made in the U.S.A. and backed by Reiser service.

Specifications

- Motor:
 - 125 HP, 230/460 volts
 - 150 HP, 460 volts
- Hopper:
 - 600 lb. capacity
 - 38.5" above floor
- Discharge:
 - Left, right, or front of machine
- Dimensions:
 - 41" wide x 69.25" long x 38.5" high
- Weight:
 - 2,500 lbs.

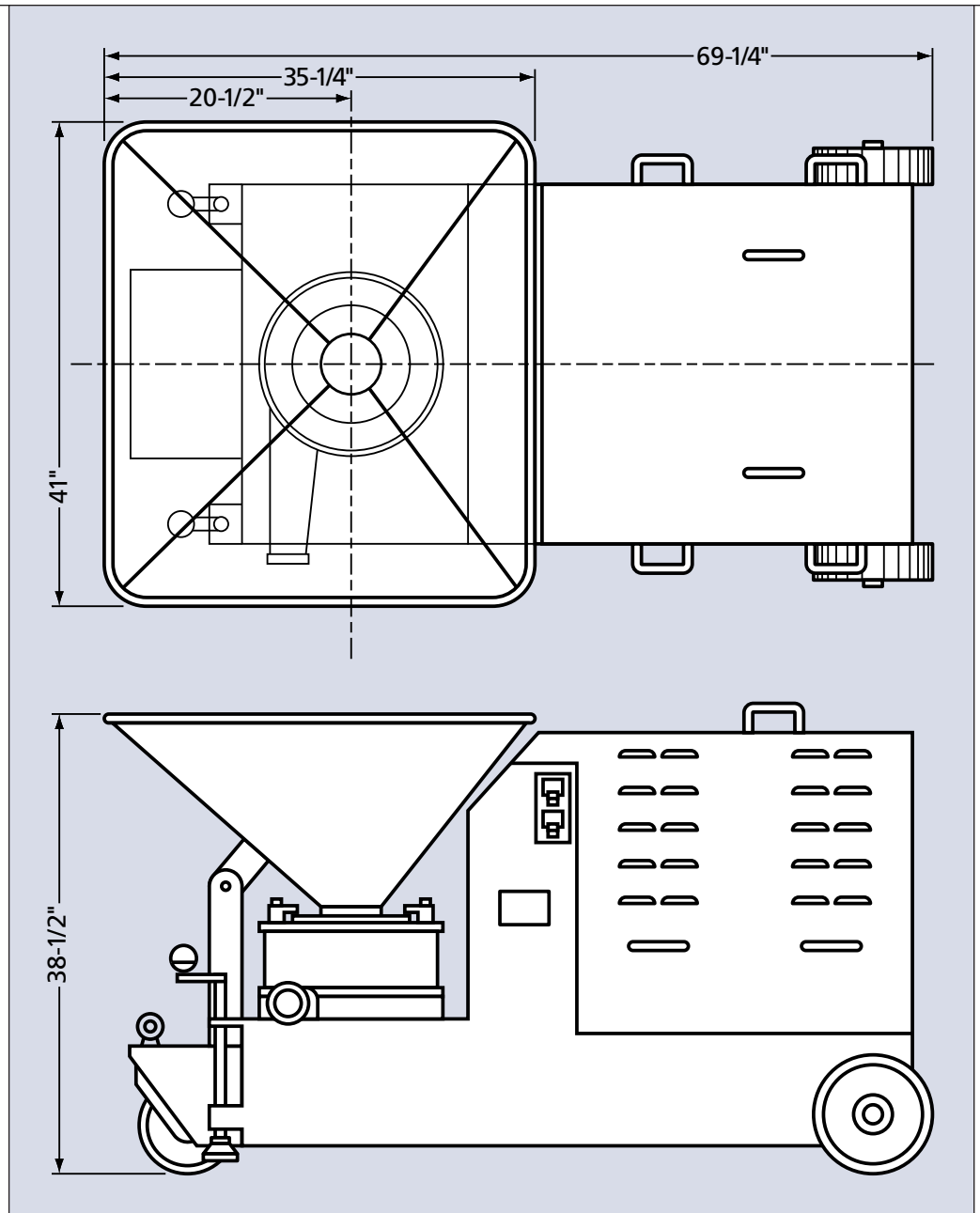

Reiser

725 Dedham Street
Canton, MA 02021
Telephone (781) 821-1290
Fax (781) 821-1316

Reiser Canada

1549 Yorkton Court, Unit #4
Burlington, ON L7P 5B7
Telephone (905) 631-6611
Fax (905) 631-6607

Reiser UK

Maidstone Road
Kingston, Milton Keynes MK10 0BD
Telephone (01908) 585300
Fax (01908) 585400

Visit us at www.reiser.com



REISER



Leading the food industry in processing and packaging solutions.