

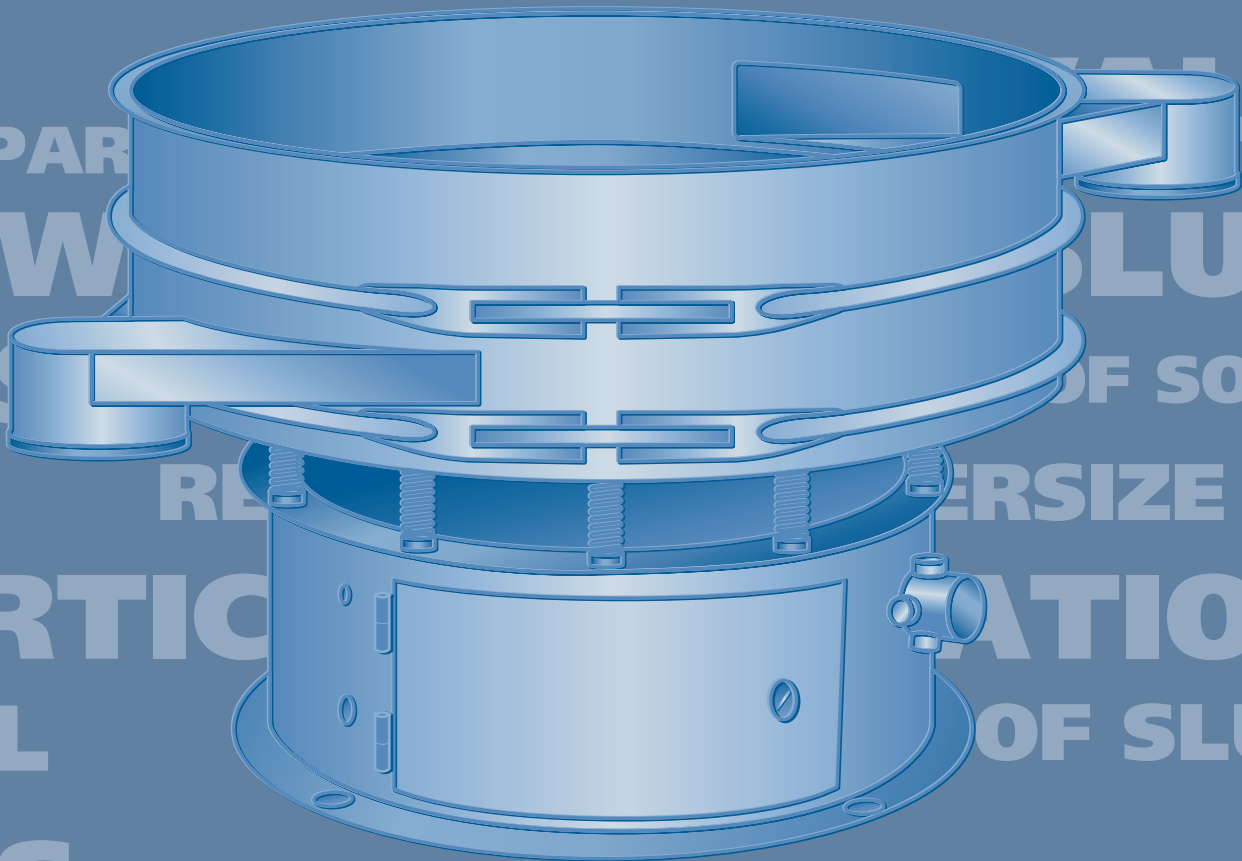

VIBRO-ENERGY[®] ROUND SEPARATORS



*Global
Leaders
in Screening
Technology*

DEWATERING OF SLURRIE

Sweco – trusted around the world

Manufacturers worldwide rely on Sweco. We span five continents with manufacturing sites, joint ventures, service offices, and sales and service representatives. So wherever you are, be assured that Sweco – the global leader in screening technology – is there when you need us.

Delivering more than machinery

When you choose Sweco, you get more than a piece of equipment. You get 60 years of technological innovation. Superior engineering. Problem solving. And with our extensive worldwide rep force, customer support is always close at hand. Whether you use our testing facilities in the United States, Belgium – or we bring our expertise onsite to your location – we can help you perfect your process to maximize output, efficiency and consistency while minimizing downtime and waste.

Sweco is recognized for our commitment to the highest quality management and environmental standards, earning various ISO registration standards in our manufacturing facilities around the world.

Through R&D, superior engineering and unparalleled customer support, you can feel confident turning to Sweco for solutions, not just machinery.



Sweco Advantages and Features

Sweco designs are highly versatile and can be customized to your requirements. With over 60 years of design experience in separators, we have developed hundreds of options and components that can be used to optimize a solution for your process. Sweco's extensive database of engineering designs allows us to "plug-and-play" with these components to develop your solution.

Widest Range of Materials Screened.

Only Sweco separators can handle such a broad range of materials... wet or dry, fine or coarse, heavy or light. Particles as fine as 400 mesh can be screened at high production rates.

Single or Multiple Separations.

As many as four screen decks can be incorporated in one Sweco Separator, providing simultaneous separation into five fractions.

Less Blinding.

Vibro-Energy action holds most screen blinding to an acceptable minimum. However, certain materials have inherent blinding characteristics. For unusual situations, Sweco has developed accessories to eliminate blinding.

Greater Capacity.

In comparative tests, Sweco Separators have shown greater capacity per square foot of screening area (from 1 to 90 sq. ft.) than other types of screening devices.

Highest Efficiency.

Our nearly infinite (patented) no-tools force wheel adjustment coupled with our computer motion analyzer system assures more efficient processing than any other screening device. Sweco's portable motion analyzer is made available to all customers through our technical audit aftermarket service program.

Longer Screen Life.

Each screen cloth is held in uniform tension by drawing it taut on tension rings. The drum-tight screening surface vibrates freely without whipping against rigid supports, greatly reducing screen wear and increasing screen life.

Minimal Transmitted Vibration.

No special flooring or foundation is generally required. The unit may be placed (and easily moved) wherever it is needed. Many users mount their Sweco units on casters, on top of bins, on open grids, on wood, on upper floors, or on light structures not designed for rectangular vibratory screening equipment.

Less Space Required.

For equivalent capacity, Sweco Avalanche Separators require less working floor space than other screening systems. Compact Sweco Low Profile units normally fit right into existing production lines.

Economy—Long Life,

Less Power, Low Maintenance.

Simplicity of design with few moving parts assures long life with little maintenance. Because of efficient design, Sweco Separators require less horsepower than other units of similar capacity. Remarkably long screen life and the ease with which screens may be changed result in further economies.



Vibro-Energy® Separators - Interior View

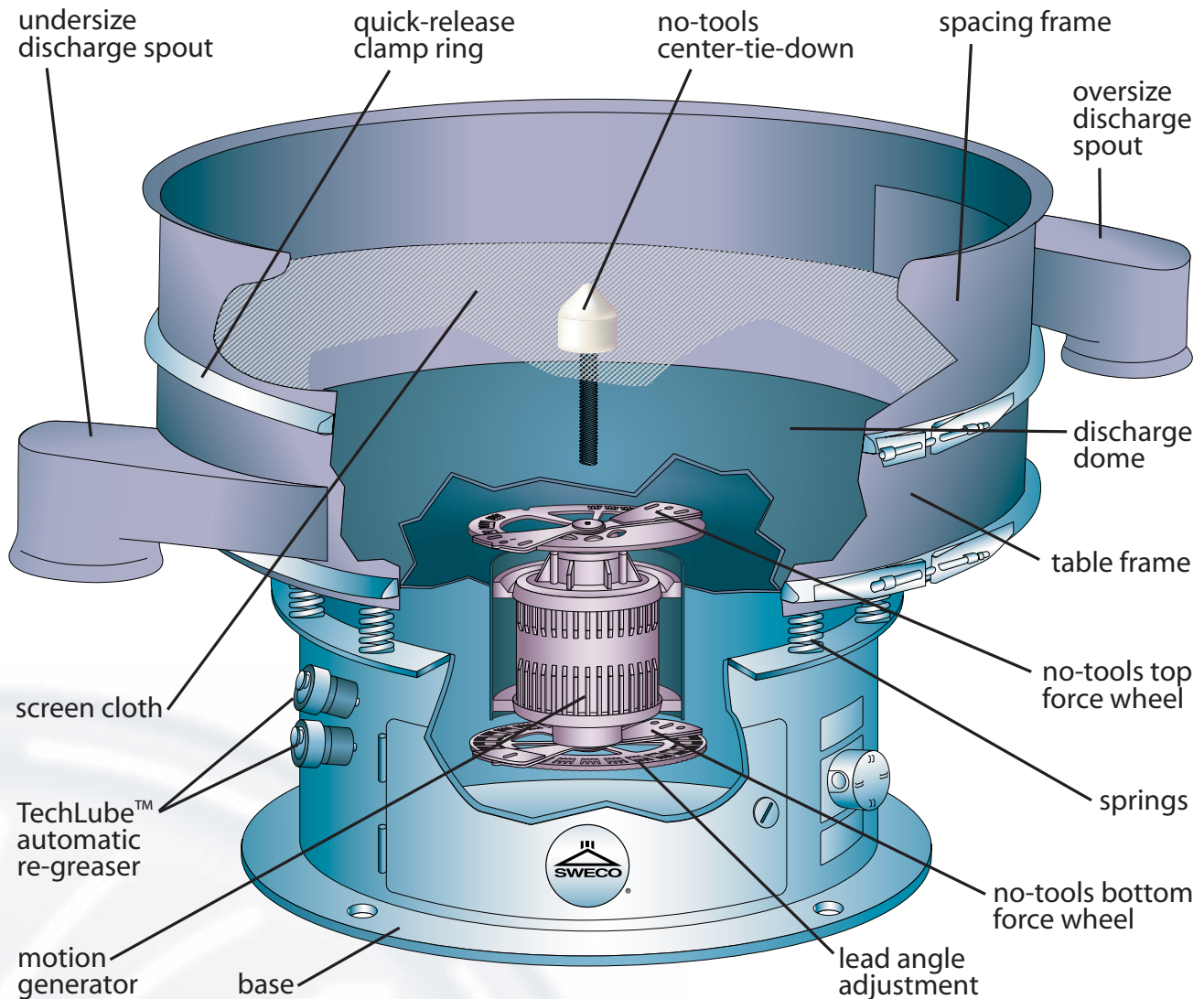

How Sweco® Vibro-Energy® Separators Work

Basically, the Sweco Separator is a screening device that vibrates about its center of mass. Vibration is accomplished by eccentric weights on the upper and lower ends of the motion-generator shaft. Rotation of the top weight creates vibration in the horizontal plane, which causes material to move across the screen cloth to the periphery. The lower weight acts to tilt the machine, causing vibration in the vertical and tangential planes. Speed and spiral pattern of material travel over the screen cloth can be set by the operator for maximum throughput and screening efficiency of any screenable product... wet or dry... heavy or light... coarse or fine... hot or cold.



0 Lead – Material is thrown straight and gives insufficient separation

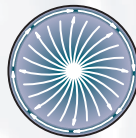

15 Lead – Material begins to spiral

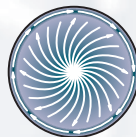

35 Lead – Gives material maximum efficient screening pattern



90 Lead – Keeps oversize material from being discharged and assists in receiving maximum throughput of minus material which tends to “ball”

Separation Processes

Sizing

Segregation of a variety of solid particles into separate groups containing comparable sizes. Up to 5 separations simultaneously.

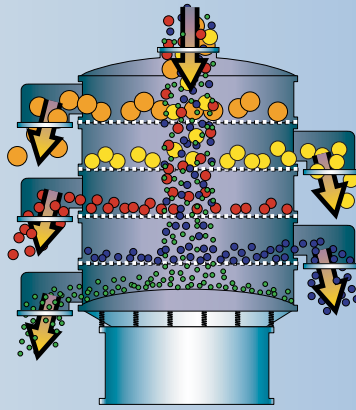

Dry Products

Sugar - spices - starch - soybeans - sawdust - salt - instant potatoes - animal feed - sand - abrasives - grit/shot-glass beads - detergents - rubber - polystyrene beads - paint - iron oxide - lead - tungsten carbide - ceramic and metallic powders - milling products - powdered pharmaceuticals - chemical and food products

Scalping

Removal of a small quantity of undesirable oversize particles in a high-throughput process.

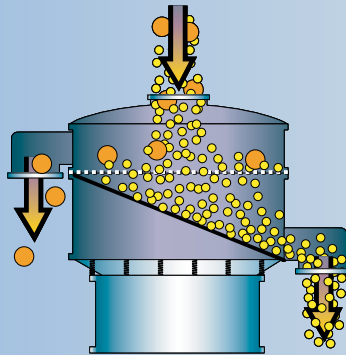

Dry Material

Powdered milk - cereals and grains - sugar - instant coffee granules - chocolate powder - soybean flour - broth concentrate - potato granules - borax - abrasives - carbon black - metal powders - sand - paint - casein - plaster - detergents - fertilizer - tobacco - bone, blood and feather meal

Gravity Filtering / Product Recovery Filtering oversize solids from all types of slurries, or dewatering solid/liquid mixtures. Reclaiming usable solids or clarifying liquids, either of which has further economic value.

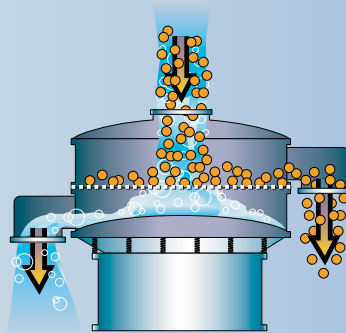

Solid/Liquid Mixtures

Fruit juices - fish - soybean oil - brewer's yeast - sugar beets - other food products - latex - paint - catalyst - pulp and paper - carpets - animal blood - tallow - ceramic - kaolin - metallurgy - pharmaceuticals - ice cream

Wastewater Clean-Up and Water Pollution Control Efficient recovery of usable solids, and water clean-up and re-use.

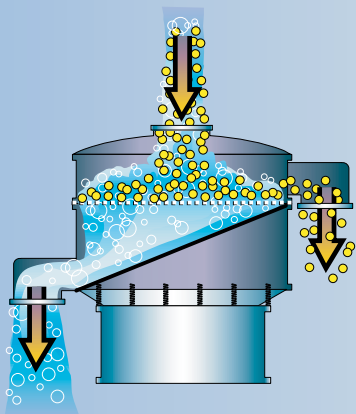

Effluent Streams

Potato peelings and waste - fruits - other food products - latex and other chemical products - manure - sewage - fruit - vegetable and pickle canneries - meat - poultry and seafood processors - brewery waste - laundry waste - pulp and paper effluent

Vibro-Energy® Separators for all your screening needs

PharmASep™ Filter/Dryer

A fully contained Vibro-Energy filter/dryer suitable for aseptic processes in the pharmaceutical, food and specialty chemicals industries. With a design that eliminates gaps, crevices and hidden areas, the PharmASep proves valuable to those processes handling potent or toxic substances. In the case of wet sieving, the PharmASep can dewater and vacuum dry the product on the screen eliminating additional handling and equipment. CIP/SIP capability is available for all PharmASep filter/dryers.

Sono-Energy™ System

The Sono-Energy creates a secondary ultrasonic vibration that prevents blinding on fine meshes (60-635 mesh) as well as improving flow rates on hard-to-screen products at fine meshes. Numerous applications exist for epoxy powders, powder paints and toner powders. Sono-Energy also works well on heavy density powdered metals including lead, nickel and chromium by preventing lodging of near-size particles.

Sanitary Separator

The Sweco Sanitary Separator meets all requirements of 3A sanitary standards and FDA requirements for food processing applications. Constructed of 304 stainless steel and polished to a #4 finish, the sanitary separator is designed to prevent product build-up and contamination.

Low Profile

High capacity, wet or dry scalping in a compact, low headroom design. Dual motors mounted on opposite sides of the Low Profile allow unrestricted flow of material and create the 3-D motion that allows discharge of oversize material, keeping the screen clear for maximum product flow. Its low headroom requirement (as little as 15 inches) and straight flow design allow the Low Profile to fit easily into existing product lines.

WWW.SWECO.COM
TECH LIBRARY

Download a PDF of any Sweco product brochure. Just log on to www.sweco.com and click on TECH Library



PSI™ Sifter

The Pneumatic Sweco In-line (PSI) Sifter is used to sift dry flowing material in a pressurized pneumatic conveying line. It can be used to segregate smaller particles from larger and to remove foreign matter. Typical applications include flour, starch, salt, sugar and plastics.

Accu-Feed™ System

Sweco's Accu-Feed System combines the three functions of storage, feeding and screening of dry materials into one complete unit. The result is a substantial increase in productivity and significant savings in capital, space and energy. With its conical storage bin and adjustable feed controller, the Accu-Feed eliminates the need for stand-alone feed hoppers, hopper evacuators and feeders.

Avalanche™

The dual screen design of the Avalanche separator effectively increases active screen area by up to 67%. The design is simple: a standard diameter frame is modified to accommodate a standard screen on the bottom with an additional, slightly smaller screen above. Material fed to the top screen either passes through the screen or discharges off the sides to be rescreened by the lower screen. The Avalanche is particularly beneficial in dry applications requiring high capacity scalping (PVC, starch, flour) as well as high efficiency dedusting (EPS beads, dry chemicals).

Vibro-Energy® Separators

Separate solids from liquids or segregate dry materials into various sizes. Particles as fine as 400 mesh (38 microns) can be screened with up to 4 screen decks incorporated in one Sweco Separator. No special flooring or foundation is needed unless working floor space is required. Simple and efficient design requires less horsepower. No one has more experience creating round separation solutions ... we've been 'round for more than 60 years!

QuickChange™ NV Separator

The patented QuickChange NV reduces screen changing to a one-person operation, greatly reducing the necessary labor and eliminating the need to involve maintenance crews. Powered by a self-contained hydraulic unit, screen changes can be made quickly, significantly reducing downtime and greatly increasing productivity.

Authentic Sweco Aftermarket Products

Superior Screening Solutions

From spot welded screens to our patented Supertaut® Plus screens, Sweco offers the industry's widest variety of screen solutions to meet any separation challenge. In addition to our round screen offerings, Sweco also manufactures Rectangular and White Water Filter screens. And for unique screening applications, Sweco custom manufactures screens to meet any requirements. Sweco offers a full line of Market Grade, Tensile Bolting Cloth, Clear Opening and U.S. Standard Sieve Cloths. Our specialty screen products include Sanitary, 3A Sanitary, UltraSonic, Parallel Flow and 430 Magnetic offerings. Like our separation equipment, Sweco screens are made with a commitment to superior manufacturing and quality. Whatever your screening needs are, Sweco has your solution.



my.sweco.com

You can now purchase all your aftermarket products online!

Login to register or contact Sweco at +1 (800) 80 SWECO



Motion Generators™

Sweco Motion Generators have extra-strong, high tensile strength castings which provide rugged vertical mounting support for severe vibration service. Their larger, tougher Sweco engineered bearings provide higher dynamic load capabilities for longer Motion Generator life. Sweco offers TENV, TECP and Hostile Duty Motion Generators. In addition, we offer the Sweco REPAIR PLUS program, backed by a guarantee on all repairs and rebuilds.

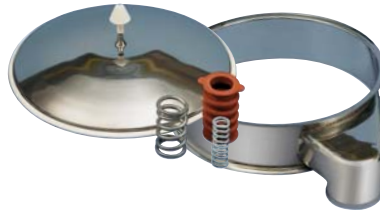

Authentic Sweco Aftermarket Covers, Springs, Spout Connectors, Frames... All of Sweco's genuine Aftermarket parts are built to the same exacting standards as our original equipment and most products can be modified to custom-fit your application. We offer a wide variety of customization options including hand polishing, frame linings and special fittings. And Sweco authentic Aftermarket products are so dependable ... they're guaranteed.



Smart-Lock™ Force Wheels

Sweco's patented all-metal weight adjustment mechanism can be used at up to 400 degrees Fahrenheit. The "No Tools" Force Wheels allow you to adjust the amplitude and screening pattern of your separator without the use of tools. We have also incorporated a positive locking tab to prevent slippage of the weight plates. Simple, ergonomic design and easy-to-read settings make this weight system user friendly. Force Wheels are available for 24"-72" separators.



Self-Cleaning Kits

Sweco's Self-Cleaning Kits aid in screen cleaning for increased screening efficiency. By reducing the amount of near-size particles lodged in the openings of the wire mesh (blinding), the Self-Cleaning Kit improves dry sizing and liquid/solid separation.



We offer screens that meet specifications from these and other industry organizations.



Rubber Goods

To accommodate your different applications, Sweco offers a variety of rubber goods. Sweco gaskets are available in several profiles and a wide array of materials. Our flexible spout connectors are available in durable and abrasion-resistant elastomers, many of which are FDA approved for contact with food products. Whatever your application calls for, Sweco has a product to fit your needs.



No-Tools Center Tie Downs

Take the hassle out of changing screens with Sweco's patented "No-Tools" Center Tie Down. This option allows you to change a screen in a fraction of the time and gives you the ability to tension the screen from the top. Center Tie Downs work with or without Sweco's Self Cleaning Kit option. They are suited to 220 degrees Fahrenheit and are constructed of Food Grade Nylon.



TechLube™

Eliminate manual regreasing with the Sweco TechLube – an automatic grease relubricator. The TechLube is an economic solution to attaining proper grease relubrication. Made to adapt directly to existing Sweco Motion Generators, TechLube provides the right grease at the right time in just the right amount. Custom packed with Sweco premium grease, TechLube is the smart choice for your Motion Generator.

Authentic Sweco Instrumentation



SentryScan™ Performance Monitoring System

Using patented microwave technology, Sweco SentryScan continuously monitors separator screens for breaks, holes or tears in the wire mesh. Early detection by SentryScan makes possible timely corrective action that can help prevent production of off-spec product, contamination of downstream equipment, costly material reprocessing or even product recalls.

Motion Analysis System

Fine tune your separator motion to increase capacity, increase efficiency and reduce blinding. Sweco's Motion Analysis System perfects the motion of your Sweco Separator – and lets you apply it to every machine in the plant. Reproduce that optimum motion at other plant locations, too. Use our integrated instrumentation package to turn your Windows PC or laptop into an easy-to-use, multi-axis dynamic motion analyzer. Or, call one of our field techs to visit your plant for full diagnostic and optimization service on all your Sweco Separators.

Vibration Sensor

Stop unexpected – and undetected – separator shutdowns and prevent costly reprocessing. Sweco's Vibration Sensor constantly monitors the motion of your Sweco Separator and triggers an alarm if it stops functioning due to motion generator failure. In some cases, it can alert you of feed rate upsets, erratic product discharge, broken springs or loose anchor bolts and clamp bands. Add the Vibration Sensor's Display Unit for local digital readout of separator G-force. Operators can program two alarm set points, each with a relay contact output.

Bearing Temperature Sensor

Significant increases in bearing temperature can indicate impending failure. Sweco's Bearing Temperature Sensor enables operators to continually monitor the upper bearing temperature in Sweco motion generators – preventing unexpected failures, material backups, downtime and emergency maintenance.



Vibro-Energy® Separator Dimensions

With the purchase of a SWECO Separator, you are selecting a product backed by decades of manufacturing experience, engineering excellence and product innovation. As an owner of a SWECO Separator, your decision to buy the best in screening equipment brings with it these added services:

- Availability of your local SWECO District Engineer for as long as you own a SWECO Separator.
- The SWECO Application Engineering Staff, library and test facilities providing sound technical backup.
- A global presence to reassure you that wherever you go there will always be a SWECO facility or sales office to help you with your process.

Please be advised that the dimensions and weights depicted in these models are estimates. For a more accurate representation, consult your local representative or SWECO Headquarters for a certified drawing.

SWECO has patents granted and pending in the United States and other countries.

Model Number Diagram

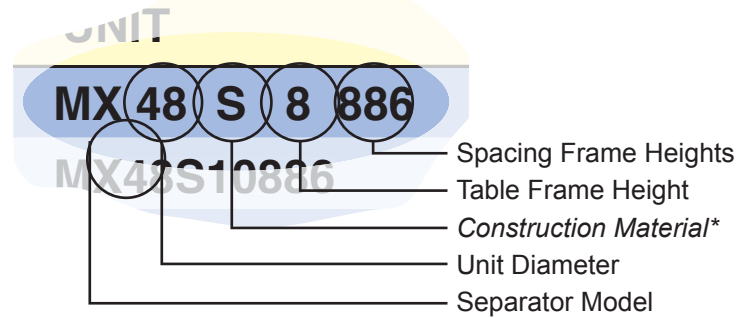

Construction Material*

SWECO Separators are available in various materials of construction. In the model number, the fifth space allocation will be characterized by one of the following: "C" designates Carbon Steel, "S" designates 304 Stainless Steel, "Y" designates 316L Stainless Steel and "K" designates special material.

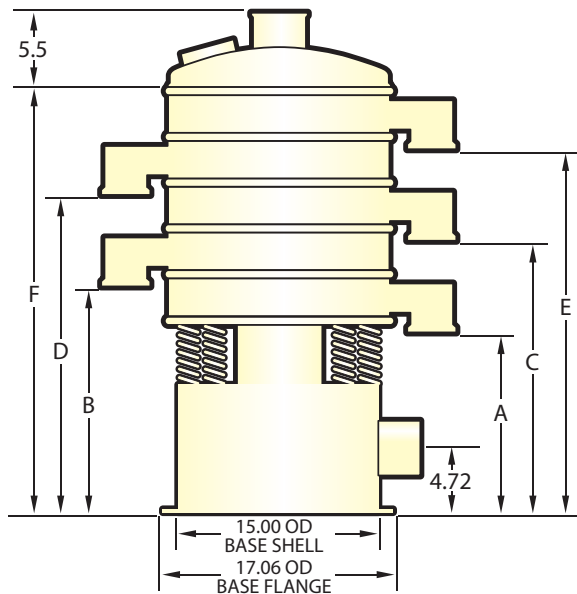

LS18

UNIT	A		B		C		D		E		F		Weight	
	in	mm	in	mm	in	mm	in	mm	in	mm	in	mm	lb	kg
LS18_33	13.6	346	17.1	435							20.9	530	200	91
LS18_55	13.6	346	19.1	486							24.9	632	204	93
LS18_333	13.6	346	17.1	435	20.5	521					24.4	619	210	95
LS18_555	13.6	346	19.1	486	24.5	622					30.4	772	216	98
LS18_3333	13.6	346	17.1	435	20.5	521	24.0	610			27.9	708	220	100
LS18_33333	13.6	346	17.1	435	20.5	521	24.0	610	27.4	695	31.3	794	230	105

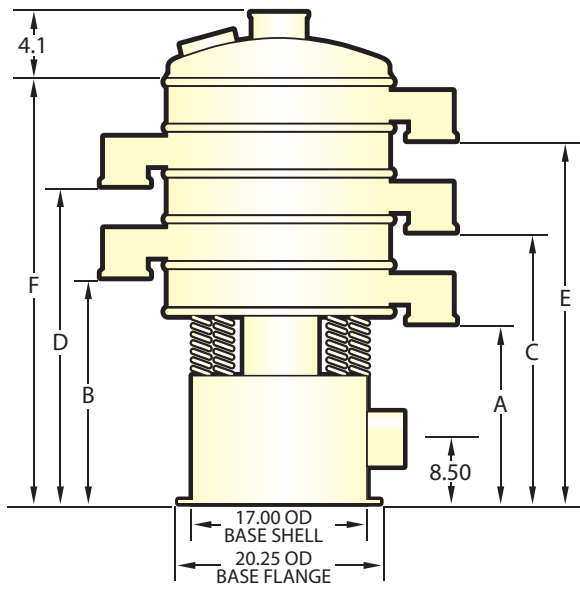

ZS24

UNIT	A		B		C		D		E		F		Weight	
	in	mm	in	mm	in	mm	in	mm	in	mm	in	mm	lb	kg
ZS24_44	15.08	383	19.55	497							25.09	637	250	113
ZS24_66	15.08	383	21.55	547							29.09	739	260	118
ZS24_444	15.08	383	19.55	497	24.02	610					29.56	751	275	124
ZS24_6666	15.08	383	21.55	547	26.02	661					33.56	852	285	129
ZS24_4444	15.08	383	19.55	497	24.02	610	28.49	724			34.03	864	300	135
ZS24_44444	15.08	383	19.55	497	24.02	610	28.49	724	32.96	837	38.50	978	325	147

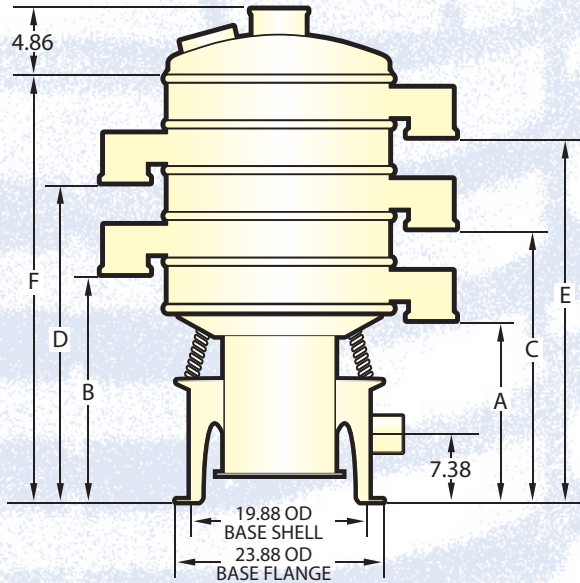

MX30

UNIT	A		B		C		D		E		F		Weight	
	in	mm	in	mm	in	mm	in	mm	in	mm	in	mm	lb	kg
MX30_66	16.76	426	23.13	587							30.51	775	400	182
MX30_666	16.76	426	23.13	587	29.75	755					37.13	943	475	216
MX30_6666	16.76	426	23.13	587	29.75	755	36.25	920			43.63	1108	525	239
MX30_66666	16.76	426	23.13	587	29.75	755	36.25	920	42.64	1083	50.13	1273	600	273

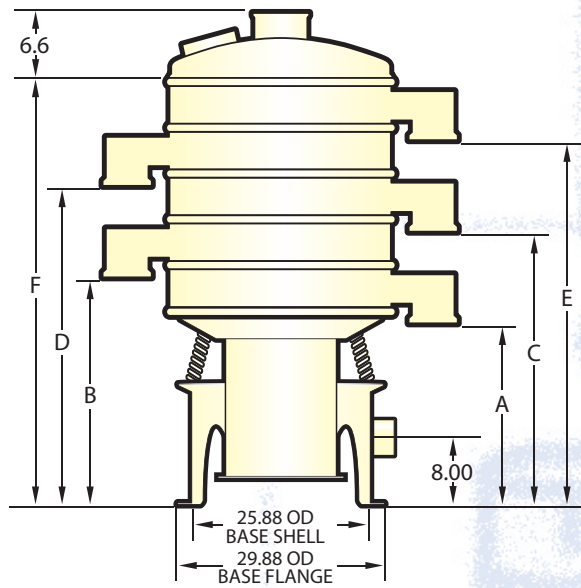

MX40

UNIT	A		B		C		D		E		F		Weight	
	in	mm	in	mm	in	mm	in	mm	in	mm	in	mm	lb	kg
MX40_66	21.19	538	27.66	703							35.20	894	550	250
MX40_88	21.19	538	29.66	754							39.20	995	575	261
MX40_666	21.19	538	27.66	703	34.13	867					41.67	1059	625	284
MX40_888	21.19	538	29.66	754	38.13	965					47.67	1208	675	307
MX40_6666	21.19	538	27.66	703	34.13	867	40.60	1027			48.14	1218	700	318
MX40_8888	21.19	538	29.66	754	38.13	965	46.60	1180			56.14	1370	725	330
MX40_66666	21.19	538	27.66	703	34.13	867	40.60	1027	47.07	1090	54.61	1377	775	352
MX40_88888	21.19	538	29.66	754	38.13	965	46.60	1180	55.07	1395	64.61	1532	775	352

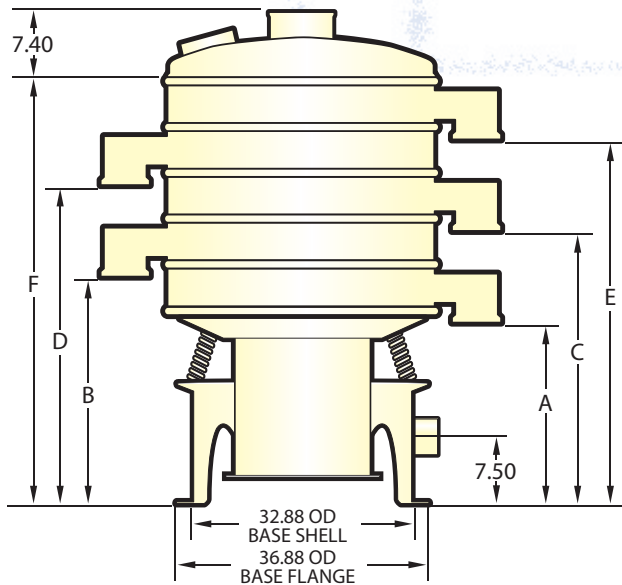

MX48

UNIT	A		B		C		D		E		F		Weight	
	in	mm	in	mm	in	mm	in	mm	in	mm	in	mm	lb	kg
MX48_66	22.69	576	29.19	741							36.57	928	725	330
MX48_88	22.69	576	31.19	792							40.57	1030	725	330
MX48_666	22.69	576	29.19	741	35.57	903					43.07	1093	825	375
MX48_888	22.69	576	31.19	792	41.57	1005					49.07	1246	825	375
MX48_6666	22.69	576	29.19	741	35.57	903	42.07	1068			49.44	1255	925	420
MX48_66666	22.69	576	29.19	741	35.57	903	42.07	1068	48.57	1233	55.81	1417	1025	466

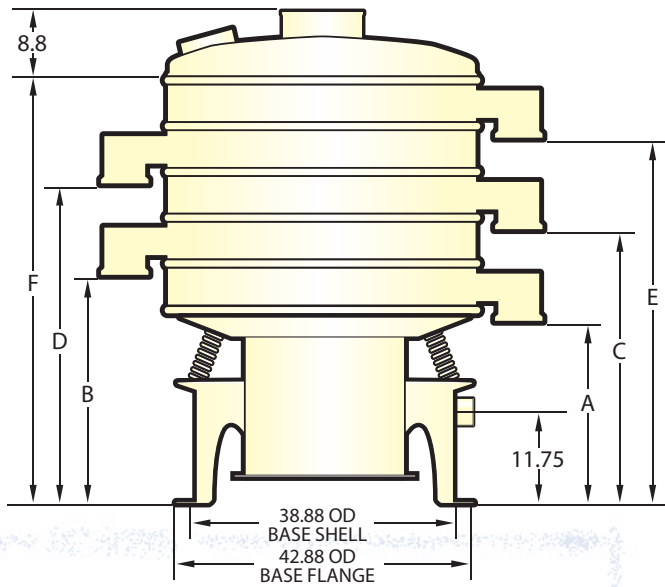

MX60

UNIT	A		B		C		D		E		F		Weight	
	in	mm	in	mm	in	mm	in	mm	in	mm	in	mm	lb	kg
MX60_86	21.25	539	29.75	755							37.13	943	725	330
MX60_88	21.25	539	29.75	755							39.13	993	750	341
MX60_810	21.25	539	29.75	755							41.13	1044	775	352
MX60_886	21.25	539	29.75	755	38.13	968					45.63	1159	900	409
MX60_888	21.25	539	29.75	755	38.13	968					47.63	1209	900	409
MX60_8106	21.25	539	29.75	755	40.13	1019					47.63	1209	900	409
MX60_8108	21.25	539	29.75	755	40.13	1019					49.63	1260	900	409
MX60_81010	21.25	539	29.75	755	40.13	1019					51.63	1311	925	420
MX60_8886	21.25	539	29.75	755	38.13	968	46.65	1184			54.00	1371	1025	466
MX60_8888	21.25	539	29.75	755	38.13	968	46.65	1184			56.00	1422	1025	466
MX60_88888	21.25	539	29.75	755	38.13	968	46.65	1184	55.12	1400	64.56	1640	1150	523
MX60_888810	21.25	539	29.75	755	38.13	968	46.65	1184	55.12	1400	66.56	1691	1660	755

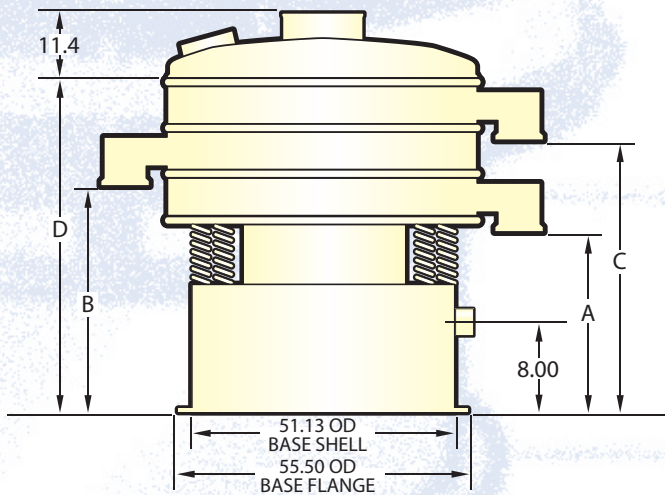

XS72

UNIT	A		B		C		D		Weight	
	in	mm	in	mm	in	mm	in	mm	lb	kg
XS72_108	22.41	569	33.01	838			42.76	1086	1800	818
XS72_1010	22.41	569	33.01	838			44.76	1137	1975	898
XS72_1012	22.41	569	33.01	838			46.76	1188	2000	909
XS72_10108	22.41	569	33.01	838	43.54	1106	53.25	1353	2050	930
XS72_10128	22.41	569	33.01	838	45.54	1157	55.25	1403	2100	955

Your Process Solutions Provider for Screening, Separating and Grinding Equipment



Rectangular Separators.
New technology adapts ultra-fine screen mesh for use in rectangular high-capacity separators (up to 48 ft² per deck), yielding benefits previously found only on small circular screens. Fine-mesh screen panels can be installed in five minutes without tools. Once in place, an O-ring system creates a positive seal against bypass.



Sta-Sieve® Stationary Screening Devices.
Provides quick and efficient separation of solids from liquid. Ideally suited for processors that use large quantities of water. Advantages of this low-cost unit include high flow rate, long screen life and no moving parts. Can be operated independently or as a system component in conjunction with Sweco Separators or Centrifugal Screen Concentrators.



White Water Filters.
Provides high liquid flow rate (up to 4000 gpm) fine mesh centrifugal screening to remove particles larger than screen mesh. Most commonly used for White Water screening in the paper industry, it can also handle other effluent and recycle streams. Units available to remove suspended solids down to 325 mesh (44 microns).



Turbo-Screen® Air Classifiers.
Provides continuous, precise screening of dry materials, especially in the finer particle sizes. Uses screen sizes from 20-400 mesh for efficient separation of particles ranging from 850-38 microns. Handles the most difficult materials, including electrostatic materials and particles that tend to agglomerate easily.



Centrifugal Sifter.
The new Centrifugal Modular design creates a unique centrifugal force by the rotation of beater bars, which propel material through the full-length cylindrical pre-screen and screen surface. The full-length discharge chute collects screened product, while oversize materials are removed through the forward discharge chute. The CM, designed for processes where hygiene is critical, contains a patented Air Tension System which enables the unit to use fine mesh screens.



Grinding Mills.
Most versatile line of mills available today for fast, low-cost particle size reduction to sub-micron range. Vibro-Energy® grinding action achieves higher output per input horsepower; precise control of size and size distribution. Product contamination from media and lining wear is virtually eliminated.

Industrial Treatment Services

Services to supply fluid processing equipment and waste management services to a variety of industries. Services include the sales and rental of equipment, one-time and ongoing cleanup services, and design and manufacture of complete turnkey systems for handling of waste streams.



GyraMax™ Rectangular Separators.
Another separation solution to further optimize your facilities' production, the GyraMax Gyratory Sifter maximizes productivity, creates a uniform sifting motion across an entire screen deck to maximize efficiency, and enables maximum recovery of clean, acceptable product.



SWECO EUROPE S.A.

Rue de la Recherche, 8
Parc Industriel Sud - Zone 1
B-1400 Nivelles, Belgium
Tel: +32 (67) 89 34 34
Fax: +32 (67) 21 43 68
europe@sweco.com



SWECO INDIA

1, New Metalage Compound
Subhash Road, Jogeshwari(East)
Mumbai 400 060, India
Phone: +91 22 2825 2140
Fax: +91 22 2825 5202
india@sweco.com



SWECO HEADQUARTERS

8029 U.S. Highway 25
Florence, KY 41042 USA
Toll Free: +1 (800) 80 SWECO
Tel: +1 (859) 283-8400
Fax: +1 (859) 283-8469
info@sweco.com



SWEQUIPOS, S.A. DE C.V.

Autopista Mex-Queretaro #3055 Km. 23.2
Col. San Andres Atenco
54040 Tlalnepantla, Estado de Mexico
Phone: +52 (5) 55 5321 9800
Fax: +52 (5) 55 5565 9818
epsa@avante.net



SWECO ASIA

63 Hillview Ave. #03-02
Lam Soon Industrial Bldg.
Singapore 669569
Tel: +65-6762-1167
Fax: +65-6762-1313
asia@sweco.com



Macon, Georgia
USA



Tulsa, Oklahoma
USA



Edinburgh
Scotland



Berra
Italy



Victoria
Australia



We Put Technology In Motion™

www.sweco.com
info@sweco.com

SWECO has sales agents and/or licensees in most countries.