



M42BC

Vertical Stockroom Baler

The M42BC Vertical Stockroom Baler is the Ideal Solution For:

- Convenience Stores
- Office Developments
- Hotels/Motels
- Hospitals/Nursing Homes
- Restaurants
- Department Stores
- Drug Stores

When you need a common sense answer to your daily waste problem, you need the M42BC Stockroom Baler.

Compare these features of the M42BC with the competition:

- Small size with incredible strength and durability
- Will handle a variety of materials in the harshest of environments
- Fast 11 second cycle time
- Powerful 4" cylinder with heavy-duty 1½" rod for long life
- Energy efficient motor for low operation costs and long life

- Enclosed counterbalance for upper door lifting ease
- Standard non-locking casters
- The M42BC can be rolled through a 3' X 7' doorway for easy installation

The M42BC Vertical Stockroom Baler, another great idea from Harmony Enterprises...
The Undisputed Leader in Quality Manufacturing.



M42BC Vertical Stockroom Baler

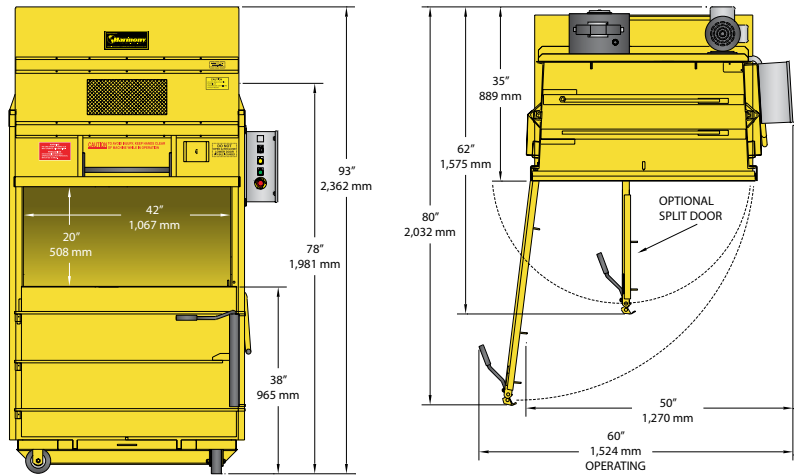

Standard M42BC Features:

- Control panel is UL® listed
- Two slots for tying bales
- Easy to service and maintain
- Meets or exceeds all ANSI and OSHA safety standards

SPECIFICATIONS

Bale Size	22" x 42" x up to 30" (559 mm x 1,067 mm x up to 762 mm)
Bale Weight (corrugated)	up to 180 lbs. (82 kg)
Ram Pressure	25,134 lbs. max (11,401 kg)
Cycle Time	11 seconds
Cylinder	4" bore (102 mm) 1.5" rod (38 mm) 10" stroke (254 mm)
Motor	2 horsepower, 1,725 RPM, TEFC
Pump	Two-stage
Electrical Power	115/230 volt, 1 phase, 60 hz
Bale Eject	Manual lever
Bale Tying	Strapping or polyethylene twine

DIMENSIONS

Loading Door Opening	20" x 42" (508 mm x 1,067 mm)
Unloading Door Height	38" (965 mm)
Overall Height	93" (2,362 mm)
Overall Depth	35" (889 mm)
Overall Width	50" (1,270 mm)
Depth with Door Open	80" (2,032 mm)
Width with Door Open	60" (1,524 mm)
Shipping Height	78" (1,981 mm)
Shipping Weight	1,475 lbs. (669 kg)
Installation and Operating Area	33.3 square feet (3.1 square meters)

Specifications subject to change without notice.



SAI GLOBAL
ISO 9001
Quality

Harmony Enterprises, Inc. 704 Main Avenue North Harmony, MN 55939 USA
1.800.658.2320 toll free | 1.507.886.6666 international | 1.507.886.6706 fax
Email us at info@harmony1.com or visit us online at www.harmony1.com

©2019 Harmony Enterprises, Inc. All rights reserved. Form HEI_M42BC_US 08/09 SC