

fomaco

Introducing the M2 series of standard injector



FGM 26 SC M2



Centrifugal pump accessible for easy, hygienic cleaning & inline filter on the pressure side of the pump to prevent blocked needles



For sanitation - conveyor belt easily removed without using tools. Conveyor frame has a quick-release system for easy, hygienic cleaning.



PLC for setting of pump pressure & speed. Constant read-out of current brine temperature.

Created with passion, designed for success

fomaco

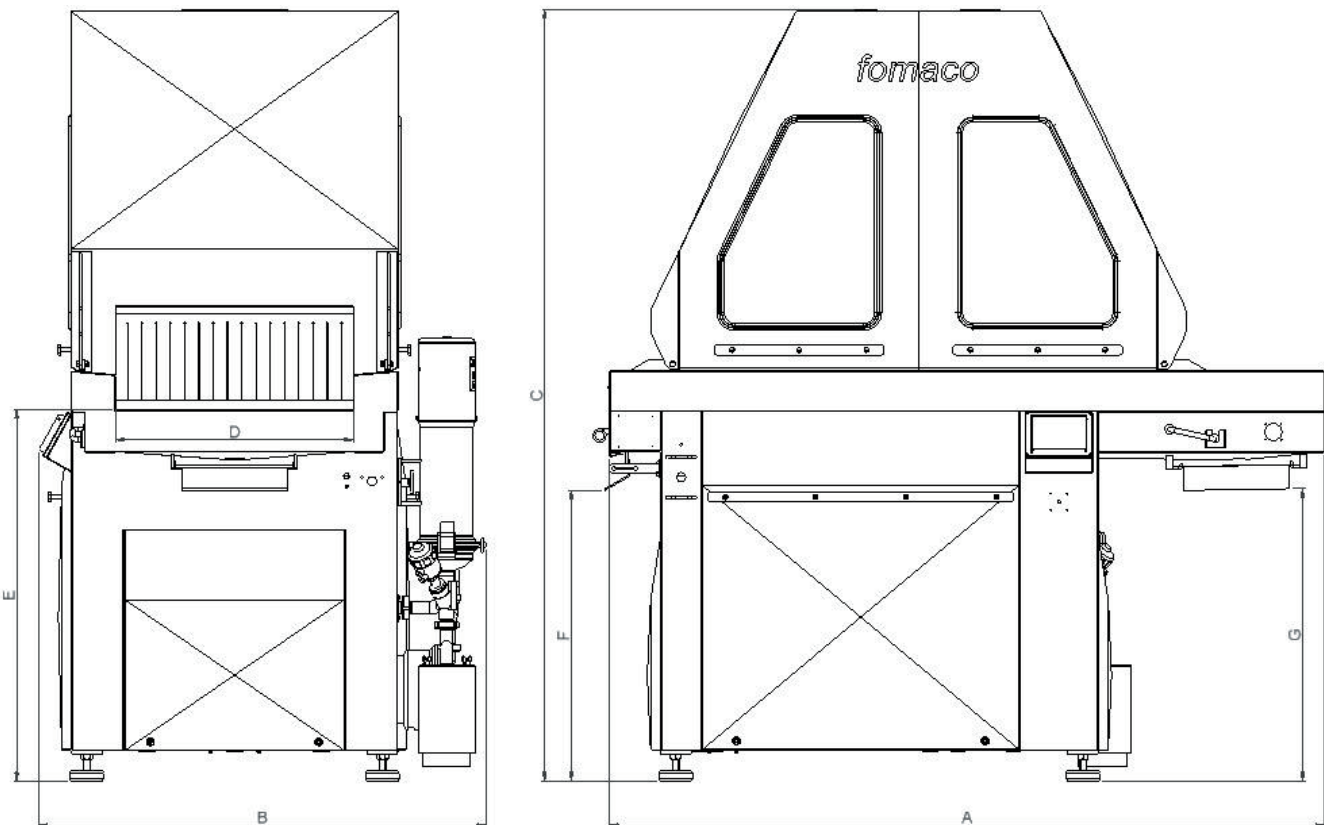

	A [mm]	B [mm]	C [mm]	D [mm]	E [mm]	F [mm]	G [mm]
FGM 26 SC M2	2100	970	2270	350	1090	860	860
FGM 34 SC M2	2100	1060	2270	440	1090	860	860
FGM 44 SC M2	2100	1190	2270	575	1090	860	860
FGM 54 SC M2	2100	1320	2270	700	1090	860	860

Specifications	
Motor	2.2 kW (FGM 26 & FGM 34) / 3.0 kW (FGM 44 & FGM 54)
Pump	Centrifugal Inoxpa
Pump motor	5.5 kW
Transport system	Conveyor belt - stainless steel or plastic
Width of transport system	350 mm / 440 mm / 575 mm / 700 mm
Product movement	30 mm or 50 mm per stroke of needle head
Speed of needle head	20-90 strokes per min
Number of needles	26, 34, 44 or 54 single, double or quadro needles
Max stroke height	230 mm
Max product height	200 mm



fomaco
 Food Machinery Company A/S
 Sandvadsvej 9
 DK-4600 Køge · Denmark

Phone: +45 56 63 20 00
 Fax: +45 56 63 20 30

www: fomaco.com
 E-mail: sales@fomaco.com

- Frequency converter for controlling the speed of the needle head is IP 66 waterproof.
- Frequency converter for pump is integrated on the pump motor.
- All other electrical components in stainless steel cabinet which is IP 66 waterproof.