

LIGHTNIN[®] CLASSIC Clamp-Mount and Fixed-Mount Mixers

Proven
performance.
Guaranteed
results.



YOU AND LIGHTNIN. THE RIGHT MIX.

LIGHTNIN

High shear. High Flow. High performance.

For your high shear or high flow mixing applications, there's a time-tested *LIGHTNIN*[®] CLASSIC Clamp-Mount or Fixed-Mount Mixer that's right for you. In fact, there have been more *LIGHTNIN* CLASSIC Mixers installed throughout the world than any other single mixer model.

How to make a great mixer even better.

Over the years, the original CLASSIC design has been enhanced in hundreds of subtle, but meaningful ways. As a result, the CLASSIC Mixer you purchase today reflects decades of continual improvement based upon years of actual performance history in just about every known fluid mixing application. And with *LIGHTNIN*'s exclusive 100% performance guarantee, you buy with complete confidence, just as hundreds of thousands of satisfied customers have done before you.

LIGHTNIN's exclusive 100% performance guarantee.

When you partner with *LIGHTNIN*, you buy with confidence, knowing your CLASSIC mixer will perform to your complete satisfaction.

LIGHTNIN's 100% performance guarantee says a lot about these mixers and your *LIGHTNIN* sales engineer. In addition, all CLASSIC mixers are backed by *LIGHTNIN*'s standard mixer warranty.

Call your *LIGHTNIN* sales engineer to discuss your mixer selection to qualify for your application guarantee.

Match the CLASSIC Mixer to Your Application

Table based on tank where liquid level is within 1.5 times tank diameter. There is no single mixer selection for any given application; mixer selection may vary with temperatures, retention times, tank shapes and specific application requirements.

Viscosity/Gallorage

Viscosity (Centipoise)	Gallorage										
	25	50	100	200	500	1000	2000	3000	5000	10000	15000
1.0	S1U10	S1U10	S1U10	XD30	XD30	XJ30	XJ30	XJ43	XJ65	XL100D	XL100F
100	S1U10	XD30	XD30	XD30	XJ30	XJ30	XJ30	XJ65	XJ87	XL100D	XL150F
250	S1U10	XD30	XD30	XJ30	XJ30	XJ43	XJ65	XJ87	XJ117	XK200F	XL300F
500	S1U10	XD30	XJ30	XJ30	XJ30	XJ65	XJ87	XJ117	XJ174	XL100H	XL200F
1,000	XD43	XJ30	XJ30	XJ43	XJ65	XJ87	XJ117	XJ174	XJ230	XL200F	
2,500	XJ30	XJ30	XJ65	XJ87	XJ117	XJ117	XJ174	XJ230	XL200F		
5,000	XJ30	XJ65	XJ87	XJ117	XJ174	XJ230	XJ350	XL200F			
15,000	XJ65	XJ87	XJ117	XJ174	XJ350	XL200F					

For Model S1U10 mixer, see Bulletin B-536.

Typical Viscosity Values at 70° F	
	Centipoise
Water	1
Gasoline	8
Kerosene	10
Sulfuric acid	25
Blood	50
Sae 10 oil	60
Olive oil	100
Glucose	500
Paint	500
Castor oil	1000
Glycerine	1500
Glycerol	1500
Catsup	3000
Molasses	3000
Honey	5000
Corn syrup	5000

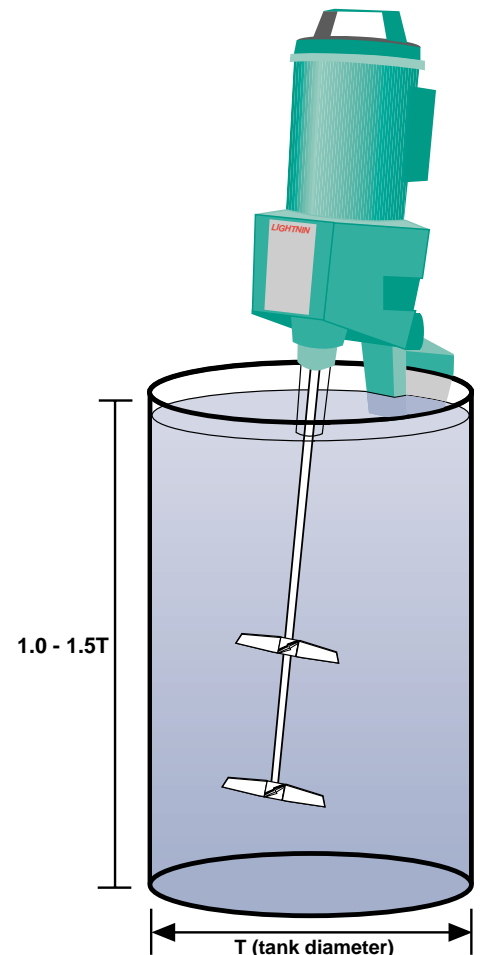

LIGHTNIN CLASSIC Direct Drive Mixers For High Fluid Shear Applications.

Clamp-mount XD Series

Where high fluid shear is desirable for small batch mixing.

Easy-positioning handle facilitates proper in-tank placement and removal.

Built-in dampener pad between housing ball and clamp socket minimizes vibration.

Single supplied wrench fits both clamp and chuck.

Standard DURA-MIX Motor is specifically designed for mixer service.

Motor and shaft are coupled directly with pilot and keyway for accurate alignment and positive connection.

One-piece aluminum housing provides exact alignment and superior mechanical strength.

Positive chuck grips the tapered flat on the mixer shaft to prevent unintentional shaft release. For added stability, rigid coupling is standard for longer shafts. Coupling is welded to the shaft.

Standard clamp securely mounts to tank rim or support. Mixer adjusts 90° vertically, 360° horizontally for optimal in-tank positioning. Indexed ball and socket lets you precisely duplicate settings. Cup mount option retains vertical and horizontal movement with indexing in a permanent mixer mount.

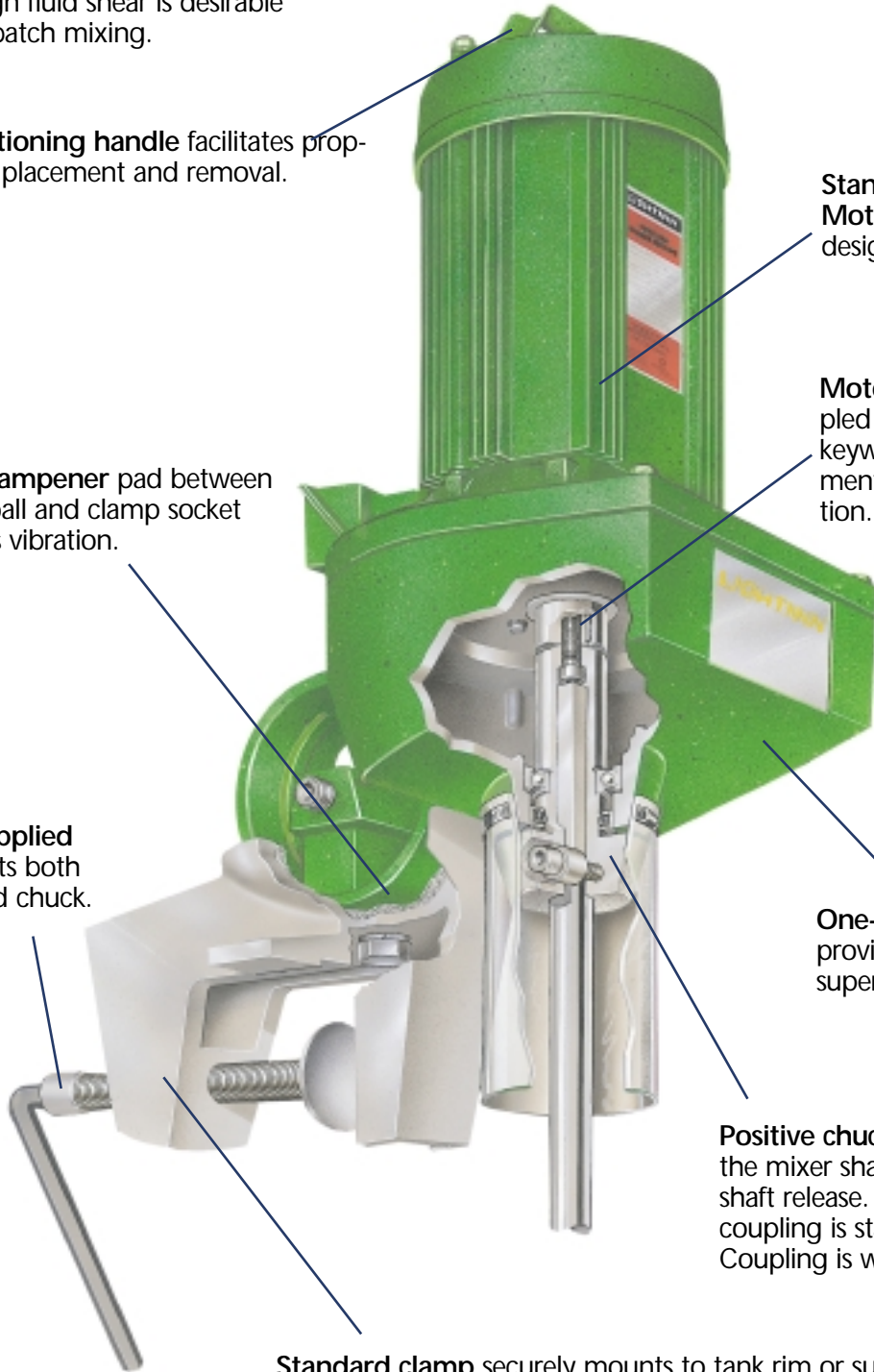

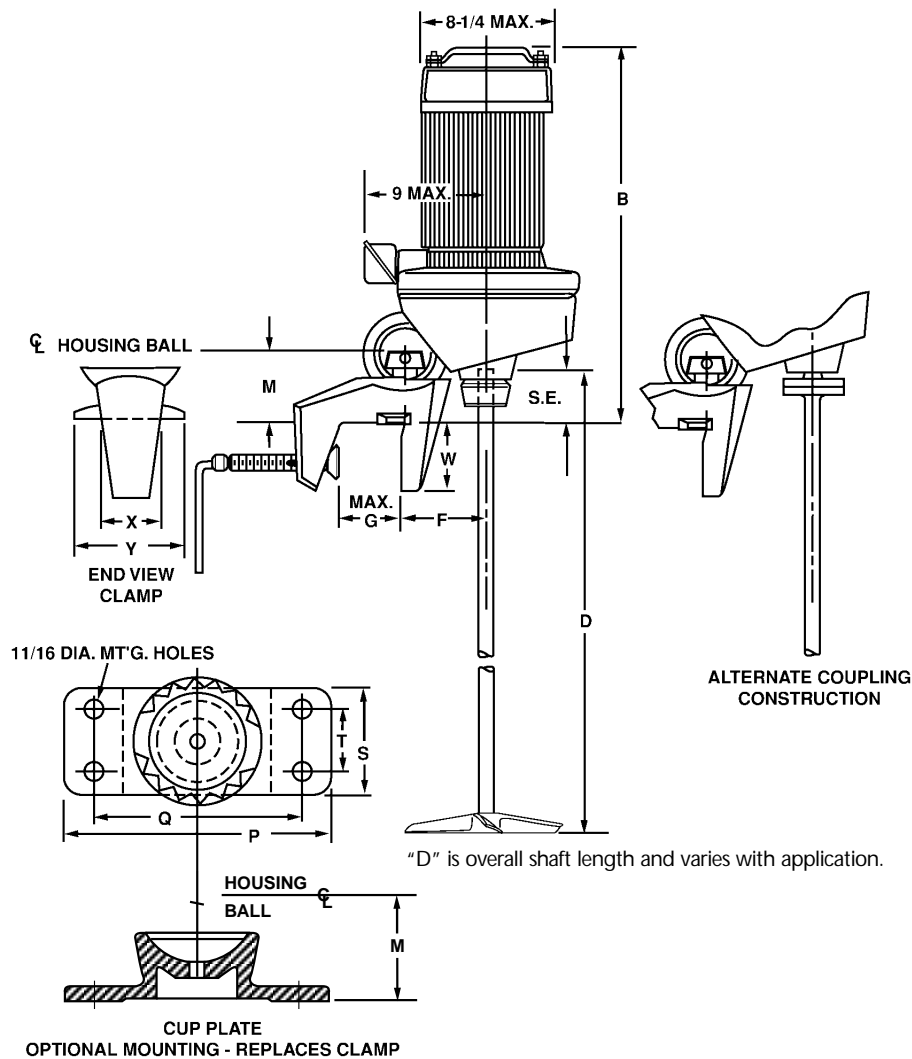

Important Reminder About Tank Selection and Mixer Mounting

In addition to specifying the *LIGHTNIN CLASSIC* mixer that's right for your mixing application, keep in mind that mixer performance greatly depends on proper tank selection and impeller placement. Here are some helpful tips to help you take full advantage of the performance characteristics of your CLASSIC mixers.

- If there are no restrictions on tank geometry, select a cylindrical vessel, making sure the liquid level is between one and one-and-a-half times the diameter of the tank.
- Impeller location should be approximately one impeller diameter from the bottom of the tank.
- The distance between any two impellers in the same tank should be equal to at least two impeller diameters for gear drive CLASSIC mixers and at least four impeller diameters for direct drive mixers.

Centered – Creates vortexing in an unbaffled tank. While normally undesirable, vortexing accelerates the dispersing and dissolving of light liquids and hard-to-wet powders.

CLAMP MOUNT, DIRECT DRIVE XD SERIES HIGH-SPEED, HIGH SHEAR MIXERS

Model	hp	Max. Wt. Lbs.	S.E.	B	F	G	M	P	Q	S	T	W	X	Y
XD30	.30	54	4.75	20	4	3	3.44	9	7	3.5	2	3.13	2.38	5.19
XD43	.43	70		4	3.75	4.19	10	8.5	3.63	2	3.5	2.88	5.75	
XD87	.87	90	5.5	21.25	4	3.75	4.19	10	8.5	3.63	2	3.5	2.88	5.75
XD117	1.17	100		23.13										
XD174	1.74	125	6.0	23.5	5	3.75	4.5	10	8.5	4	2.5	4.19	3.25	6.88
XD230	2.30	130		25.25										
XD350	3.50	135		25.25										

Fixed-mount XDO Series for open tanks

For large tanks and continuous processes that require extra long shafts and the stability of permanent installation.

- Shaft safety cover.
- See XD Series for common mixer features.
- Shock mounts protect drive against high fluid forces



Angular Off-Center – Aiming the shaft off center prevents vortexing, and eliminates the need for tank baffles. Off center positioning achieves strong top to bottom turnover. Suitable for most mixing and blending.

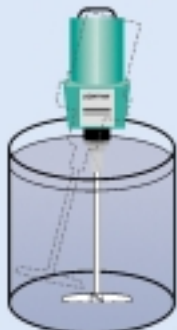

Repositioning During The Batch Clamp-mount CLASSIC mixers make it easy to reposition the impeller when more than one kind of mixing action is required.

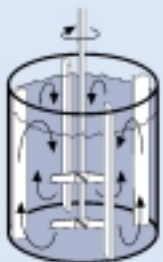

Tank Baffles – Four vertical baffles spaced 90° apart are required to avoid vortexing when shafts and impellers are center mounted. Baffle width depends on fluid viscosity and other factors. Consult your LIGHTNIN sales engineer.

FIXED-MOUNT, DIRECT DRIVE XDO SERIES HIGH SHEAR MIXERS FOR OPEN TANKS										
							With Angle Riser		Without Angle Riser	
Model	hp	Max. Wt. Lbs.	S.E.	B Max.	H	J	L	M	N	K
XDQ30	.30	51	6.25	21.5	4.0	5.38	12.25	10	4	10
XDQ43	.43	56								
XDQ87	.87	60								
XDQ117	1.17	70	6.5	24.25	5.5	7.62	16.75	13.5	5.5	13
XDQ174	1.74	135								
XDQ230	2.30	140								
XDQ350	3.50	155	26							

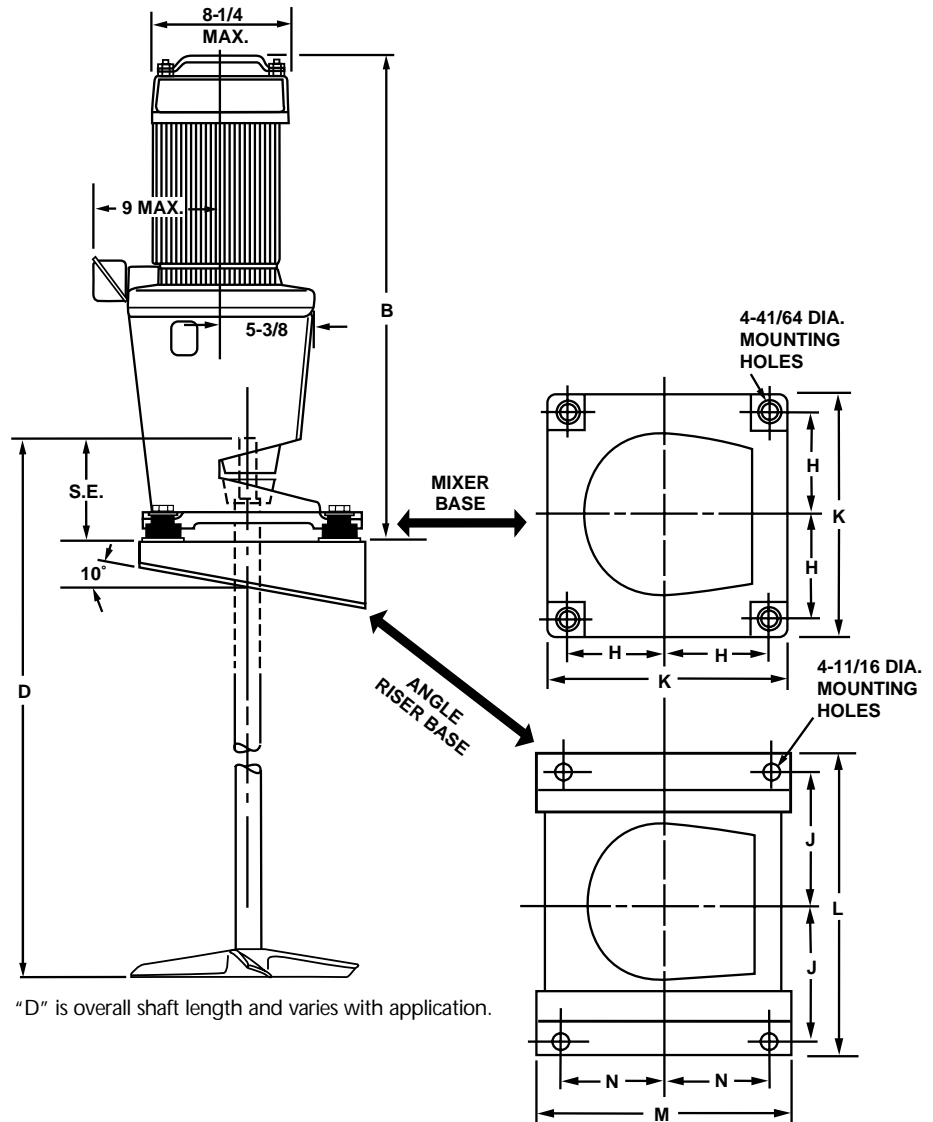

"D" is overall shaft length and varies with application.

Angle risers are furnished only when specified.

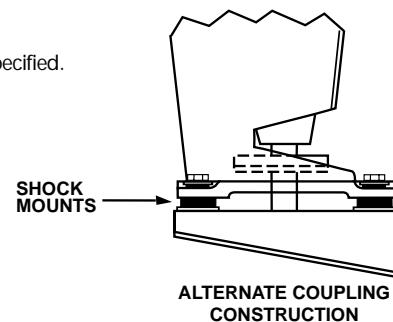

Direct Drive

Fixed-mount XDC Series for closed tanks

Features removable coupling for added stability in applications requiring long overhung shafts.

- Coupling is rabbetted and keyed to assure positive alignment.
- Standard ASA 150# series flanges are available in solid steel or steel faced with 316 stainless. Other materials and special flanges are available.
- Standard 60 psig stuffing box features 7 rings of die-molded packing with separators; a lubricant distributing GFT lantern ring, grease fitting and adjustable 316SS packing gland. Available accessories include cooling or heating jacket.
- Optional stuffing box for lower pressures features 2 rings of die-molded packing and a packing gland.
- See XD Series for common mixer features.

Fixed-mount XDDS Series for closed tanks

With double mechanical seals

- Mechanical seal provides maximum sealing with minimum maintenance.
- See XD and XDC Series for common mixer features.

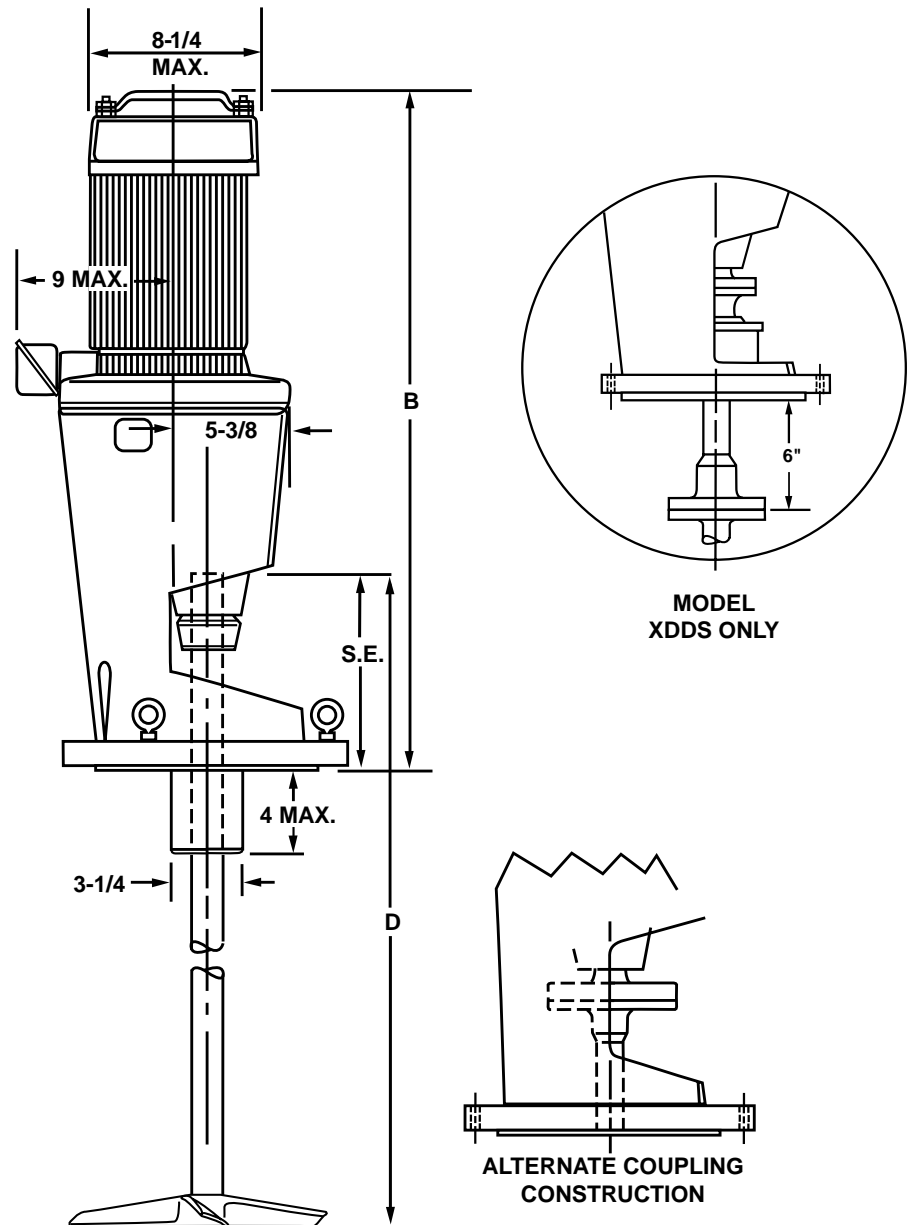

"D" is overall shaft length and varies with application.

FIXED-MOUNT, DIRECT DRIVE XDC SERIES AND XDDS SERIES (DOUBLE SEAL) HIGH SHEAR MIXERS FOR CLOSED TANKS						
Stuffing Box Model	Mechanical Seal Model	HP	Max Wt. Lbs.	S.E.	B Max.	Std. Mtg. Flange ASA*
XDC30	-	.30	102	9.75	25	5
XDC43	XDDS43	.43	120		25.33	
XDC87	XDDS87	.87	130		25.75	
XDC117	XDDS117	1.17	135		26.5	
XDC174	XDDS174	1.74	180	10.25	28.5	8
XDC230	XDDS230	2.30	186		30.13	
XDC350	XDDS350	3.50	216			

* 150# flange drilling. Bolt holes straddles centerline. Special flanges available.

Clamp-mount XDA Series air drive mixers

Operate wherever compressed air is available.

- 1/3, 1 and 3 hp
- Safe for use in flammable or explosive environments.
- Air control valve varies speeds.
- Lightweight design for easy handling.
- To extend mixer life, optional air line lubrication system filters air supply, regulates pressure and automatically adds oil to lubricate motor.

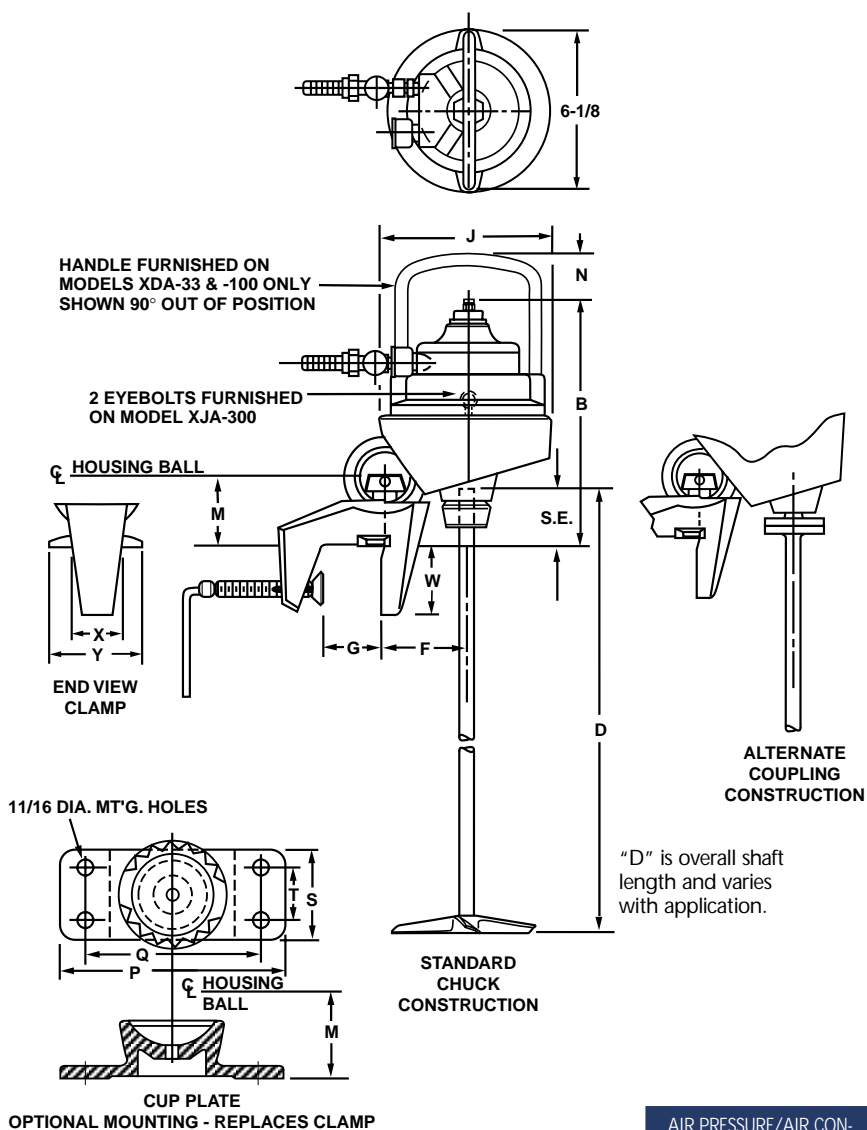

Model hp	PSIG	CFM (Free Air)
.33	60	15
1	85	30
3	70	96

Model	hp	Max. Wt. Lbs.	S.E.	B	F	G	J	M	N	P	Q	S	T	W	X	Y
XDA33	.33	30	4.75	11.25	4	3	8.00	3.44	2.38	9	7	3.5	2	3.13	2.38	5.19
XDA100	1	56	5.50	13.25		3.75	8.25	4.19	1.5	10	8.5	3.63	2	3.5	2.88	5.75
XDA300	3	72	6.00	17	5	3.75	10.25	4.50	-	10	8.5	4	2.5	4.19	3.25	6.88

LIGHTNIN CLASSIC Gear Drive Mixers For High Fluid Flow Applications.

Clamp-mount XJ Series

Provides the high torque that's required to mix viscous fluids in the 15,000 to 100,000 centipoise range.

Single reduction, internal helical gears provide high torque and are exceptionally compact and quiet.

Built-in dampener pad between housing ball and clamp socket minimizes vibration.

Single supplied wrench fits both clamp and chuck.

Standard clamp securely mounts to tank rim or support. Mixer adjusts 90° vertically, 360° horizontally for optimal in-tank positioning. Indexed ball and socket lets you precisely duplicate settings. Cup mount option retains vertical and horizontal movement with indexing in a permanent mixer mount.

Easy-positioning handle facilitates proper in-tank placement and removal.

Standard DURA-MIX Motor is specifically designed for mixer service.

One-piece aluminum housing provides exact alignment and superior mechanical strength.

Grip springs provide a keyless friction clutch to protect the gears against shock loads.

Shaft, motor bearings and gears are lifetime lubricated for continuous service.

Positive chuck grips the tapered flat on the mixer shaft to prevent unintentional shaft release. For added stability, rigid coupling is standard for longer shafts. Coupling is welded to the shaft. (Optional rigid rigid coupling is shown. Standard construction is the positive chuck.)

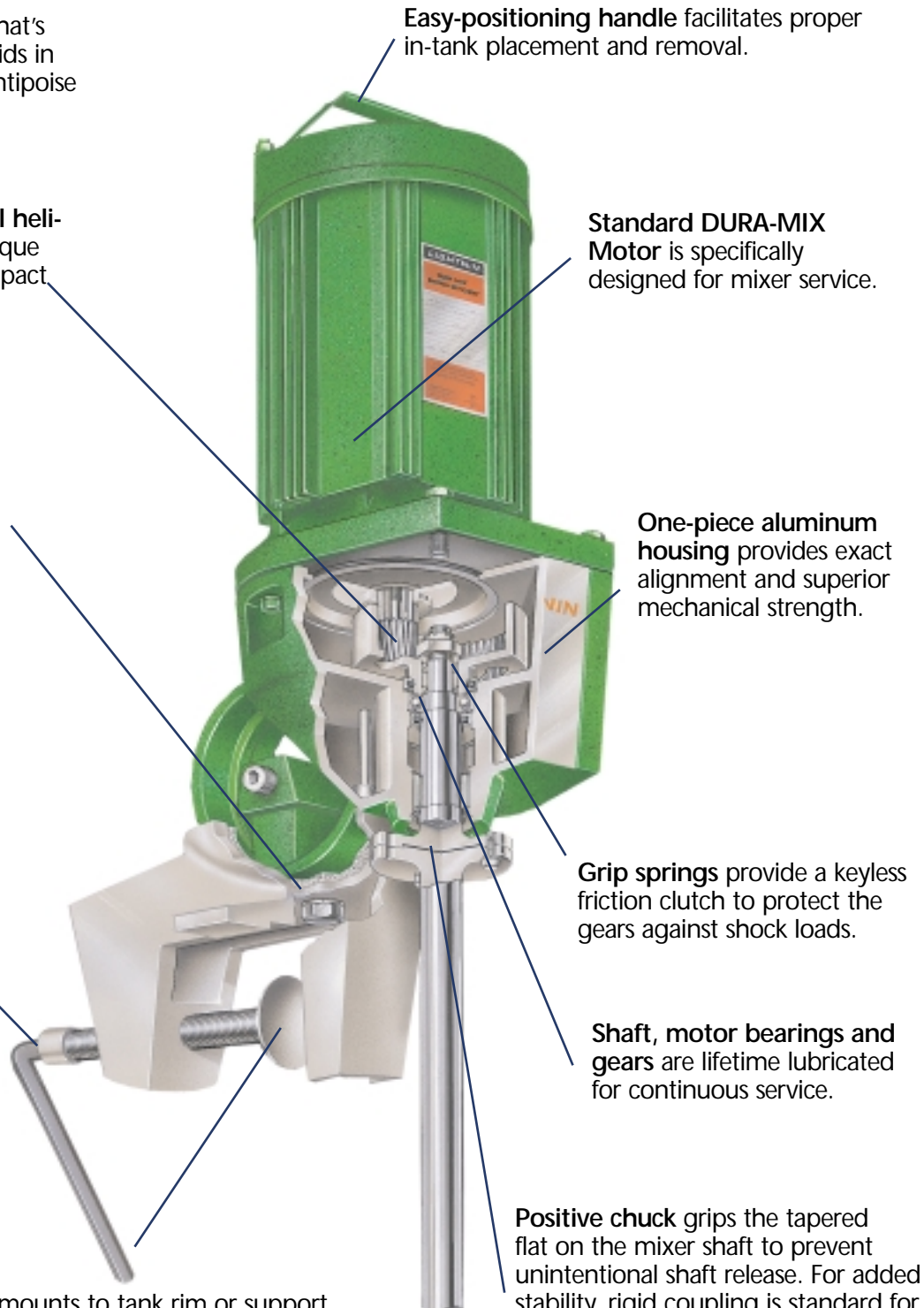

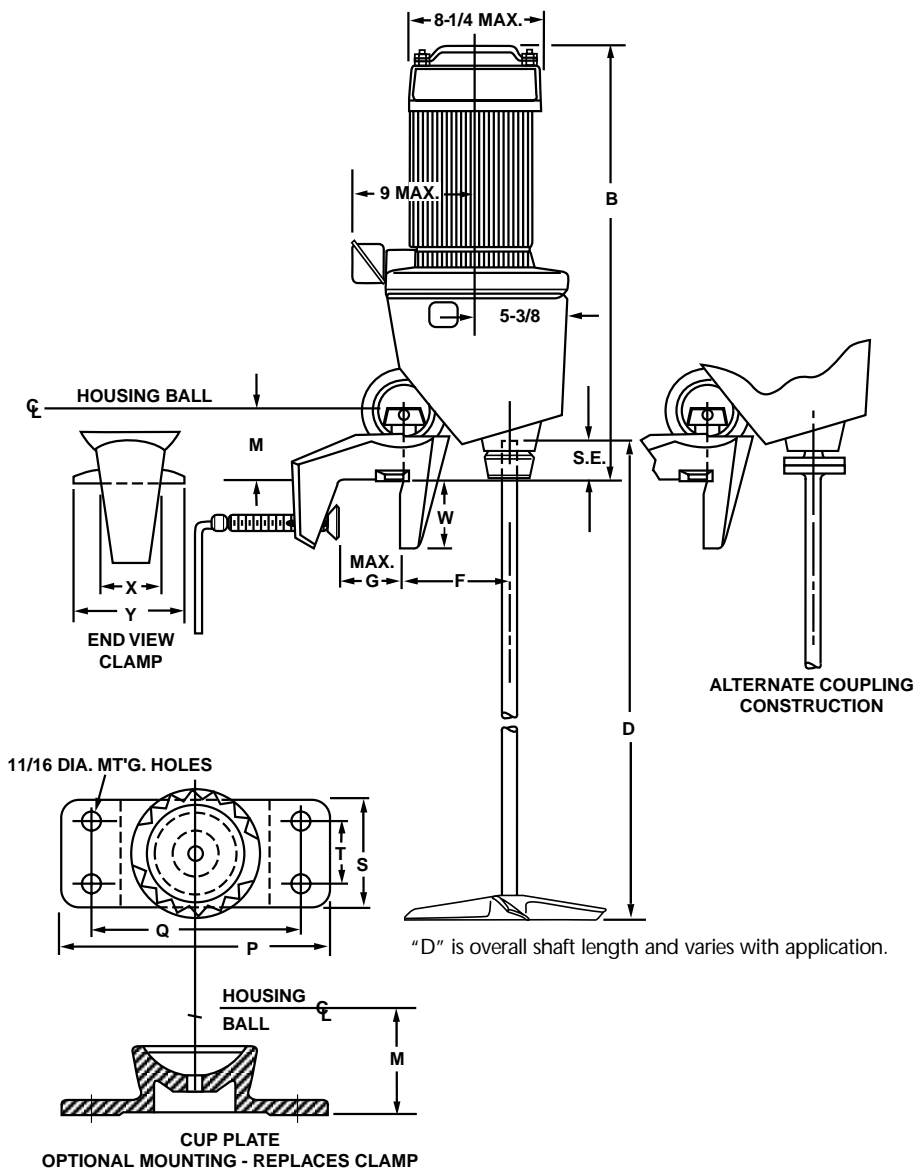

Always the Right Impeller

Over the years, *LIGHTNIN* engineers have developed the world's largest selection of high-performance impellers to meet your specific mixing requirements.

For example, *LIGHTNIN*'s high-efficiency A310 and A320 impellers develop 50% more mixing for the same horsepower, compared with conventional three-bladed, marine-type props.

A310 impellers are available in stainless, Hastelloy[®] alloys, titanium and other materials, and can be polymer or rubber coated.

A320 impellers improve blending and reduces power consumption in higher viscosity applications. It continually operates as an axial flow impeller in the transitional regime.



A310



A320

See page 10 for additional impeller options.

CLAMP MOUNT, GEAR DRIVE XJ SERIES HEAVY-DUTY HIGH FLOW MIXERS														
Model	hp	Max. Wt. Lbs.	S.E.	B	F	G	M	P	Q	S	T	W	X	Y
XJ30	.30	65	4.0	21.63	5	3	3.44	9	7	3.5	2	3.13	2.38	5.19
XJ43	.43	70												
XJ65	.65	86	4.88	23.13	5.5	3.75	4.19	10	8.5	3.63	2	3.5	2.88	5.75
XJ87	.87	94												
XJ117	1.17	100												
XJ174	1.74	125	4.62	27.25	6.5	3.75	4.5	10	8.5	4	2.5	4.19	3.25	6.88
XJ230	2.30	135		28										
XJ350	3.50	140		28.38										

Fixed-mount XJQ Series for open tanks

For large tanks and continuous processes which require extra long shafts and the stability of permanent installation.

- Units supplied with shaft safety cover.
- See XJ Series for common mixer features.
- Shock mounts protect drive against high fluid forces to prolong mixer life.

Impeller options

- The R100 radial flow turbine promotes efficient gas dispersion and gas/liquid mass transfer.
- The A100 propeller provides efficient mixing when higher fluid shear rates are required for hard-to-wet powders.
- Ring Guard impellers prevent damage from dip tubes, temperature probes and other in-tank devices.
- Folding impellers fit into the bung of 55-gallon drums and carboys as small as 1-7/8 inch in diameter. Opens to sizes from 3 to 5 inches.

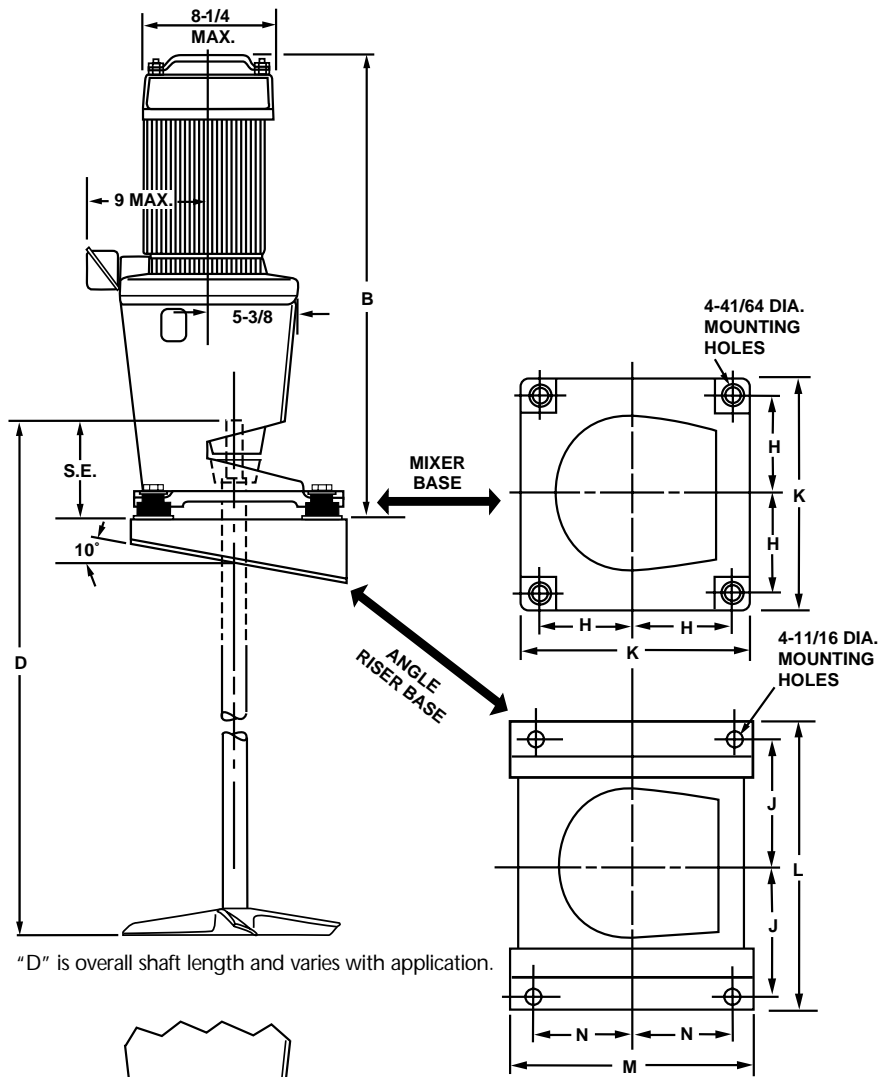
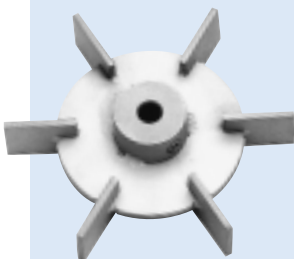

"D" is overall shaft length and varies with application.

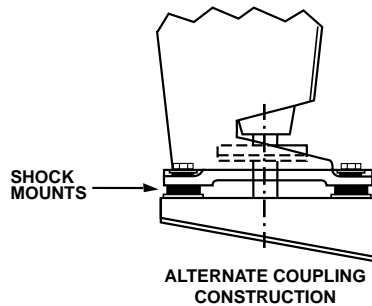

Angle risers are furnished only when specified.

FIXED-MOUNT, GEAR DRIVE XJQ SERIES HIGH FLOW MIXERS FOR OPEN TANKS										
					With Angle Riser				Without Angle Riser	
Model	hp	Max. Wt. Lbs.	S.E.	B Max.	H	J	L	M	N	K
XJQ30	.30	63	6.0	23.25	4.0	5.38	12.25	10	4	10
XJQ43	.43	66		24.63	4.5	5.88	13.25	11	4.50	11
XJQ65	.65	69	6.5	25.38	5.5	7.63	16.75	13.5	5.50	13
XJQ87	.87	83		28.75						
XJQ117	1.17	89		30.5						
XJQ174	1.74	155								
XJQ230	2.30	204								
XJQ350	3.50	255								

Fixed-mount XJC Series for closed tanks

Features removable coupling for added stability in applications requiring long overhung shafts.

- Coupling is rabbetted and keyed to assure positive alignment.
- Standard ASA 150# series flanges are available in solid steel or steel faced with 316 stainless. Other materials and special flanges are available.
- Standard 150 psig stuffing box features 7 rings of die-molded packing with separators; a lubricant distributing GFT lantern ring, grease fitting and adjustable 316SS packing gland. Available accessories include cooling or heating jacket.
- Optional stuffing box for lower pressures features 2 rings of die-molded packing and a packing gland.
- See XJ Series for common mixer features.

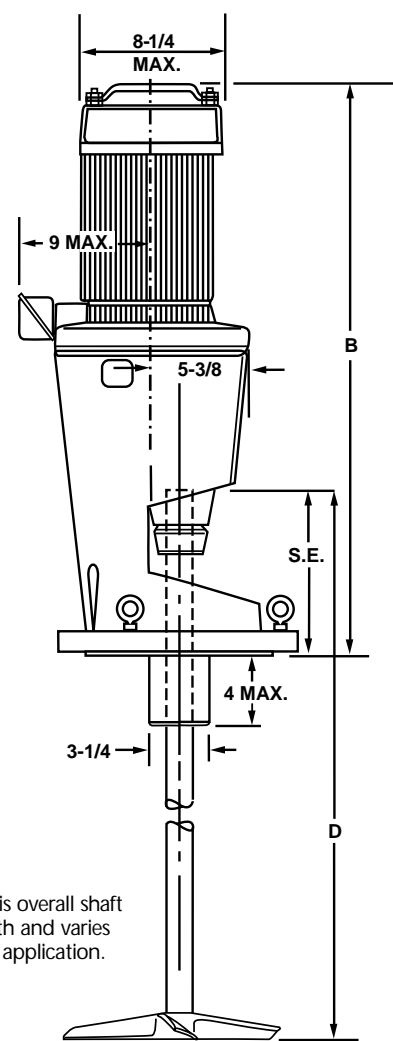
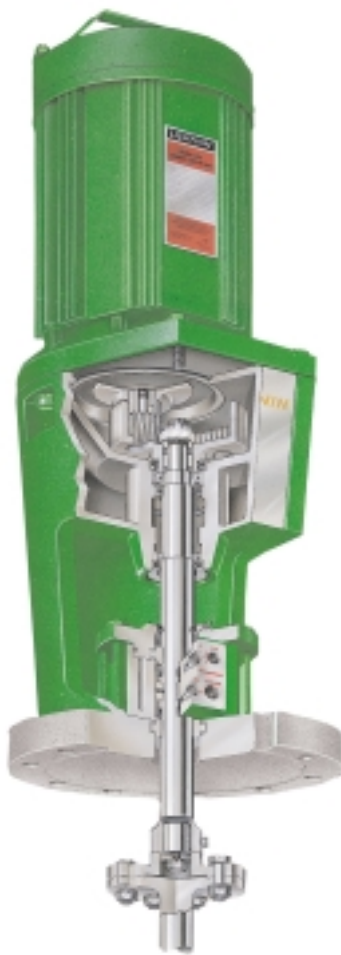

"D" is overall shaft length and varies with application.

Fixed-mount series for closed tanks

With double mechanical seals

- XJSS single mechanical seal unit (requires alternate coupling construction as shown).
- XJDS double mechanical seal unit.
- Mechanical seal provides maximum sealing with minimum maintenance.
- See XJ and XJC Series for common mixer features.

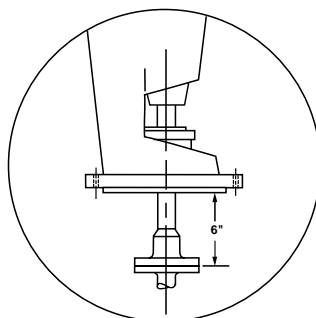

MODEL XJDS ONLY

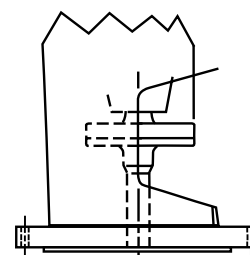

ALTERNATE COUPLING CONSTRUCTION

FIXED-MOUNT, GEAR DRIVE XJC SERIES AND XJDS SERIES (DOUBLE SEAL) HIGH FLOW MIXERS FOR CLOSED TANKS						
Stuffing Box Model	Mechanical Seal Model	HP	Max. Wt. Lbs.	S.E.	B Max.	Std. Mtg. Flange ASA*
XJC30	XJDS30	.30	105	9.5	27.5	5
XJC43	XJDS43	.43	120		27.13	
XJC65	XJDS65	.65	170	10.13	28.13	6
XJC87	XJDS87	.87	180		29.25	
XJC117	XJDS117	1.17	190		32.5	
XJC174	XJDS174	1.74	215	10.25	34.25	8
XJC230	XJDS230	2.30	225			
XJC350	XJDS350	3.50	235			

* 150# flange drilling. Bolt holes straddles centerline. Special flanges available.

Gear Drive

Clamp-mount XJA Series air drive mixers

Operate wherever compressed air is available.

- 1/3, 1 and 3 hp
- Safe for use in flammable or explosive environments.
- Air control valve varies speeds.
- Impossible to burn out the motor, even with a stalling overload.
- Lightweight design for easy handling.

Energy efficient DURA-MIX™ Motors

Designed Specifically For Mixer Service

- 6-8 percentage points higher than a standard efficient motor.
- Can be wired from 200 VAC to 480 VAC, 50 or 60 Hertz, 3 phase.
- Class FJ insulation better suited to withstand overloads or adverse conditions than Class B insulation.
- Thermostats can be wired in series with starter relay or connected to alarm. Single-phase motors have built-in manual reset circuit breakers.
- Available explosion-proof motors are available in 1/4 to 3.5 hp which meet NEC requirements for Class I, Group D and Class II, Groups F and G. Thermal protector shuts off unit if operating temperature exceeds safe limits.

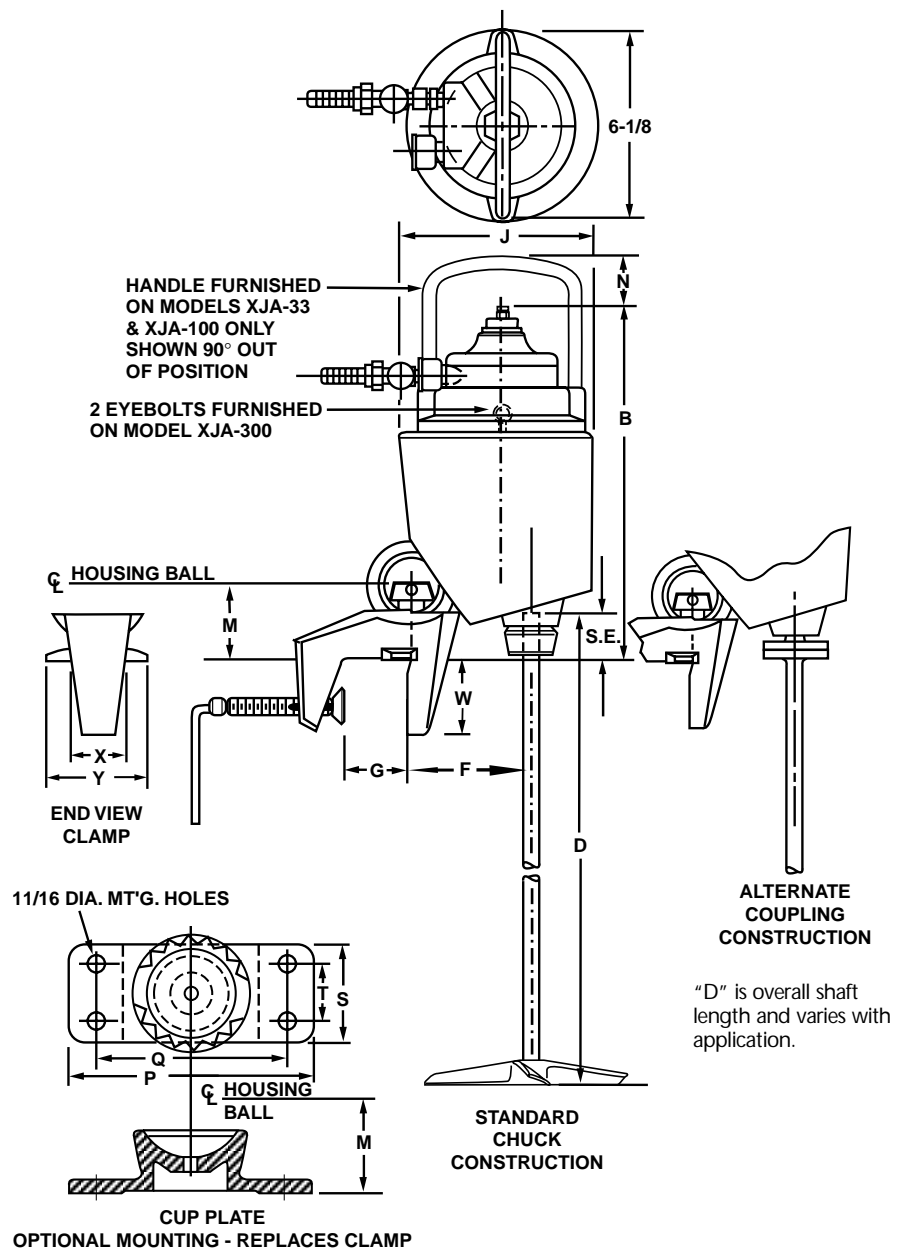
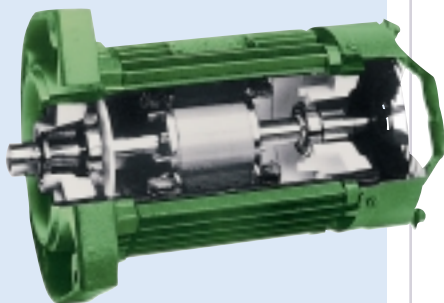

CLAMP MOUNT, GEAR DRIVE XJA SERIES AIR DRIVE MIXERS																
Model	hp	Max. Wt. Lbs.	S.E.	B	F	G	J	M	N	P	Q	S	T	W	X	Y
XJA33	.33	45	4.00	12.6	5	3	8.0	3.44	2.38	9	7	3.5	2	3.13	2.38	5.19
XJA100	1	65	4.88	14.5	5.5	3.75	8.25	4.19	1.5	10	8.5	3.63	2	3.5	2.88	5.75
XJA300	3	120	4.62	20.25	6.5	3.75	10.25	4.50	-	10	8.5	4	2.5	4.19	3.25	6.88

AIR PRESSURE/AIR CONSUMPTION GUIDE		
Model hp	PSIG	CFM (Free Air)
.33	60	15
1	85	30
3	70	96

Fixed-mount SXJ and SXJS Series side-entering mixers

Help maintain suspension for varying levels of stored materials. Also used where there isn't space for a top-entering mixer.

- Installed mixers are normally supported entirely by the tank mounting flange. Tie rods or mixer support legs can be furnished if tank nozzle lacks sufficient strength and rigidity.
- Choice of stuffing box or mechanical seal.
- Stuffing box includes 6 packing rings, lantern ring, grease fitting and adjustable packing gland. Optional shut-off device lets you repack with a full tank.
- Shut-off device permits mechanical seal change with a full tank

FIXED MOUNT SXJ AND SXJS SERIES SIDE ENTERING MIXERS					
Stuffing Box Model	Mechanical Seal Model	HP	Max. Wt. Lbs.	Std. Mtg. Flange ASA*	
				SXJ	SXJS
SXJ33	SXJS33	0.33	150	5	8
SXJ75	SXJS75	0.75	230	6	8
SXJ100	SXJS100	1.00			
SXJ174	SXJS174	1.74	260	8	
SXJ230	SXJS230	2.30	270		
SXJ350	SXJS350	3.50	280		

* 150# flange drilling. Bolt holes straddles centerline. Special flanges available.

Gear Drive

Fixed-mount, double-reduction XL Series mixers for larger vessels

Let you increase or decrease mixer speed as process requirements warrant by simply changing gears.

- DURA-MIX motor available in 1 to 5 hp. Bearings are lubricated for life. Explosion-proof model available.
- Double reduction gears and bearings are grease-lubricated for life.
- Standard rigid coupling facilitates installation of lower shaft and turbine.
- Shafts can be specified up to 15 feet for deep tanks.
- Optional angle risers eliminate the need for baffles in open tanks.

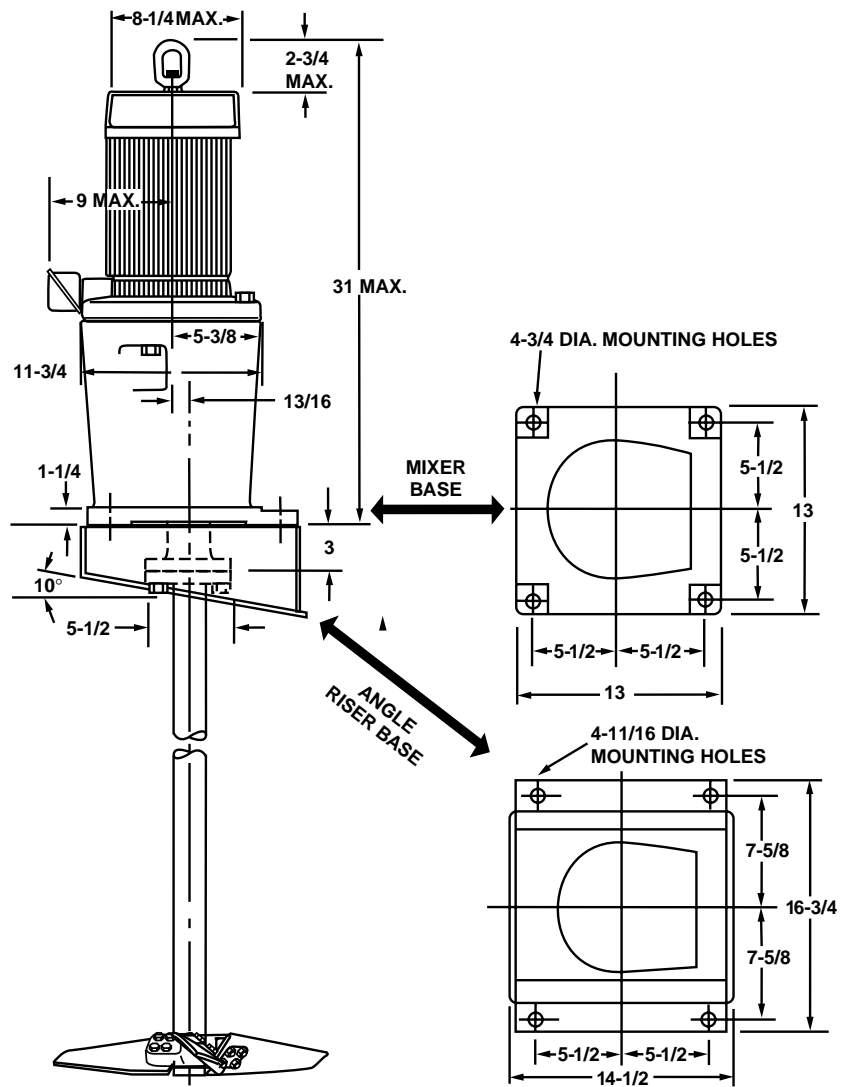

Angle risers are furnished only when specified.

XLQ MIXER FOR OPEN TANKS				
Model	hp	Basic Mixer Wt. Lbs.	Total Mixer Wt.	
			Single Impeller	Dual Impellers
XLQ-100B	1.0	186	312	328
XLQ-100D			340	354
XLQ-100F			372	400
XLQ-100H			420	468
XLQ-150B	1.5	190	313	330
XLQ-150D			340	364
XLQ-150F			373	388
XLQ-200B	2.0	195	317	334
XLQ-200D			345	348
XLQ-200F			369	375
XLQ-300B	3.0	205	323	341
XLQ-300C			345	360
XLQ-500A	5.0		329	N.R.

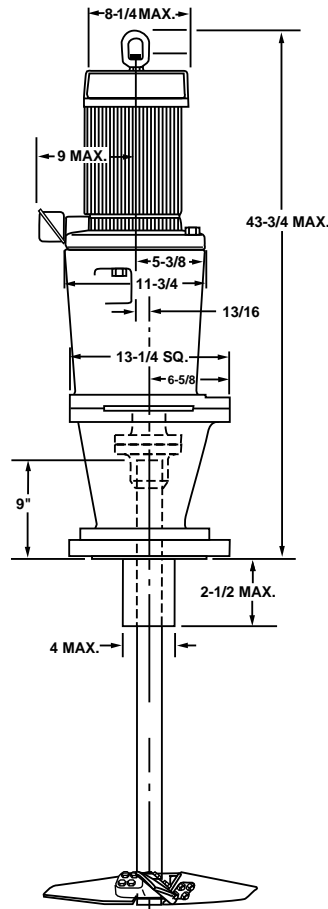
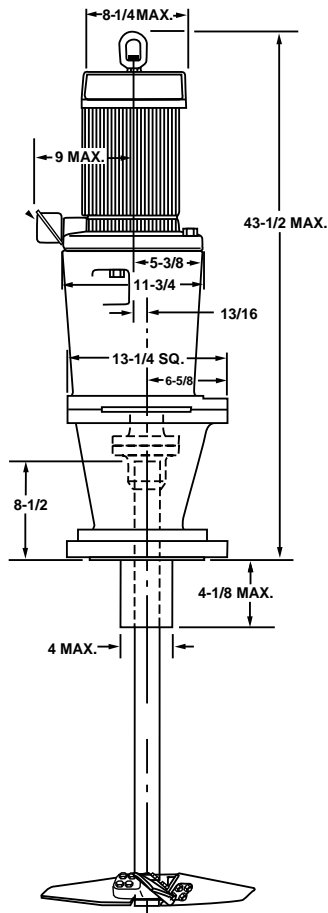

XLC MIXERS WITH STANDARD STUFFING BOX FOR CLOSED TANKS UP TO 150 PSIG					
Model	hp	Basic Mixer Wt. Lbs.	Total Mixer Wt.		Std. Mtg. Flange ASA*
			Single Impeller	Dual Impellers	
XLC-100B	1.0	290	413	429	8
XLC-100D			441	455	
XLC-100F			473	501	
XLC-100H			521	569	
XLC-150B	1.5	294	414	431	
XLC-150D			441	465	
XLC-150F			474	489	
XLC-200B	2.0	294	418	435	
XLC-200D			446	460	
XLC-200F			470	487	
XLC-300B	3.0	299	424	442	
XLC-300C	5.0	305	446	472	
XLC-500A			431	N.R.	

* 150# flange drilling. Bolt holes straddles centerline. Special flanges available.

XLS MIXERS WITH SINGLE MECHANICAL SEAL FOR CLOSED TANKS XLDS MIXERS WITH DOUBLE MECHANICAL SEAL FOR CLOSED TANKS					
Model	hp	Basic Mixer Wt. Lbs.	Total Mixer Wt.		Std. Mtg. Flange ASA*
			Single Impeller	Dual Impellers	
XLSS & XLDS-100B	1.0	300	423	439	8
XLSS & XLDS-100D			451	465	
XLSS & XLDS-100F			483	511	
XLSS & XLDS-100H			531	579	
XLSS & XLDS-150B	1.5	304	524	441	
XLSS & XLDS-150D			451	475	
XLSS & XLDS-150F			484	499	
XLSS & XLDS-200B	2.0	304	428	445	
XLSS & XLDS-200D			456	470	
XLSS & XLDS-200F			480	497	
XLSS & XLDS-300B	3.0	309	434	452	
XLSS & XLDS-300C	5.0	315	456	482	
XLSS & XLDS-500A			440	N.R.	

* 150# flange drilling. Bolt holes straddles centerline. Special flanges available.

Learn more about these and other high-performance mixers from **LIGHTNIN**. Call 1-888-MIX BEST for product literature.

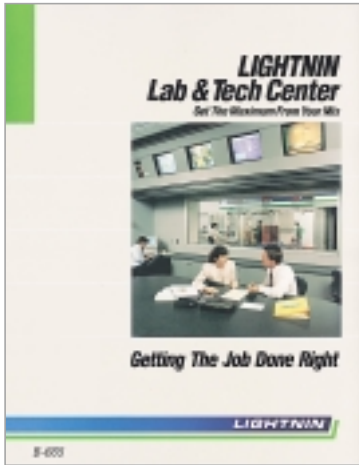

B-665

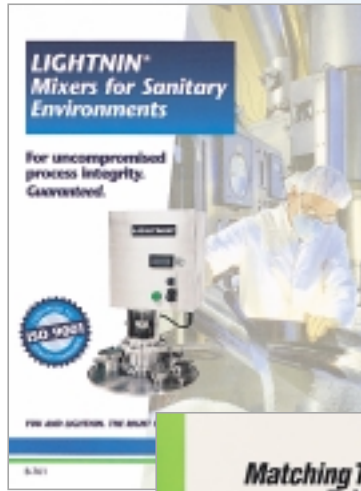

B-761



B-656



B-647



B-633

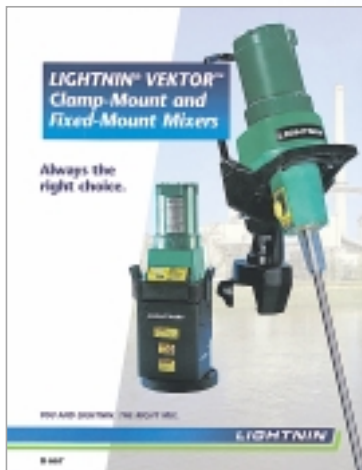

B-667



B-769



135 Mt. Read Blvd., P.O. Box 1370, Rochester, New York 14611
 Telephone: 1-888-MIX BEST, 716-436-5550 Fax: 716-436-5589
www.LIGHTNIN-MIXERS.COM

Rochester, NY, USA • Toronto, Canada • Poynton, England • Jurong, Singapore
 Sydney, Australia • Milan, Italy • Johannesburg, South Africa Shanghai, China •
 Dublin, Ireland • Seoul, Korea

