

Urschel® Models G-A/GK-A

Straight or Crinkle Slices, Strip Cuts, or Dices

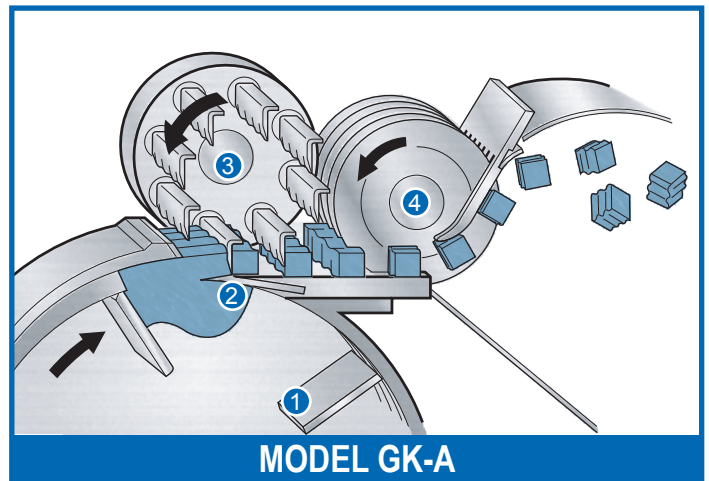

SPECIFICATIONS

Length:	73.73" (1873 mm)
Width:	45.94" (1167 mm)
Height:	49.25" (1251 mm)
Net Weight:	770 lb (349 kg)
Motor:	2 HP (1.5 kW)

APPLICATIONS

The Model G-A produces uniform dices, straight french fry strips, and slices from a variety of soft ripe fruits and brittle root vegetables.

The Model GK-A produces crinkle slices, three-dimensional cuts having four crinkle surfaces, and plain cuts from a variety of fruits and vegetables. This machine is especially suited for the production of crinkle french fry strips from potatoes.

Maximum infeed product entering either machine should not exceed 5-1/2" (140 mm) in any dimension. A wide selection of interchangeable cutting parts enables the user to obtain gentle, clean cutting through a wide range of sizes at high production capacities. Both models feature continuous operation for uninterrupted production, and are designed for easy cleanup and maintenance.

OPERATING PRINCIPLE

Product delivered to the feed hopper continues into a rotating impeller [1]. Centrifugal force holds the product against the inside of the slice case as the impeller paddles carry the product past the slicing knife [2]. An adjustable case gate at the top of the case allows the product to move outward across the edge of the slicing knife. The distance between the end of the case gate and the slicing knife edge determines the slice thickness.

As the slices emerge, crosscut knives [3] move downward producing strips. Strips move without interruption across the top surface of the slicing knife holder into the circular knives [4] where they are cut into cubes or other three-dimensional cuts of a selected size.

TYPES OF CUTS

SLICES: 1/16 to 3/4" (1.6 to 19.1 mm)

DICES: A slicing knife, crosscut knife spindle and circular knife spindle are used for dicing. Changing the size of the cubes is done by using the required cutting spindles and adjusting the slice thickness.

Slice thickness: 1/8 to 3/4" (3.2 to 19.1 mm)

Crosscut knives: 9/32 to 7/8" (7.1 to 22.2 mm)

Circular knives: 3/32 to 3" (2.4 to 76 mm)

STRIP CUTS: To make strip cuts, only the slicing knife and the crosscut knife spindle are used to make two dimensional cuts.

JULIENNE STRIPS: Julienne strips are also available. Contact your local Urschel sales representative for more information on the set-up for your application.

Urschel® Models G-A/GK-A Dimensional Drawing

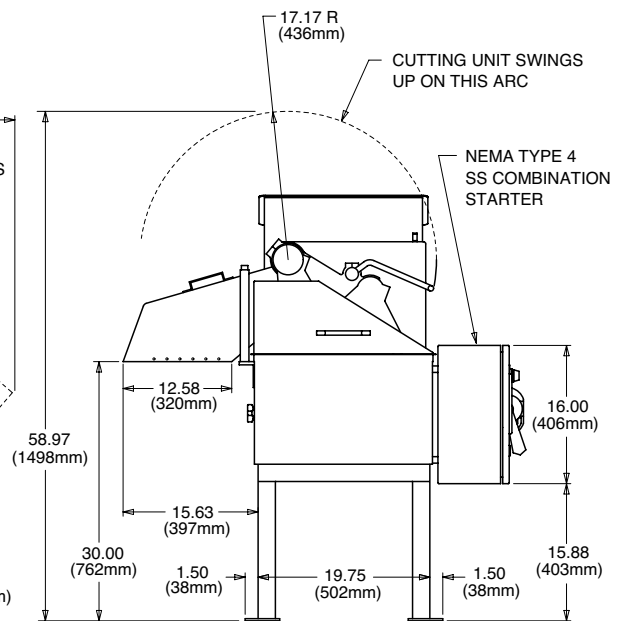
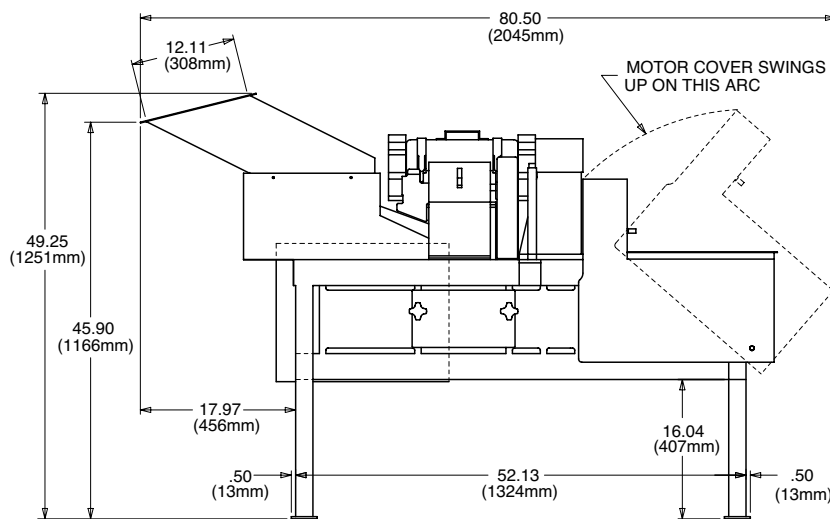
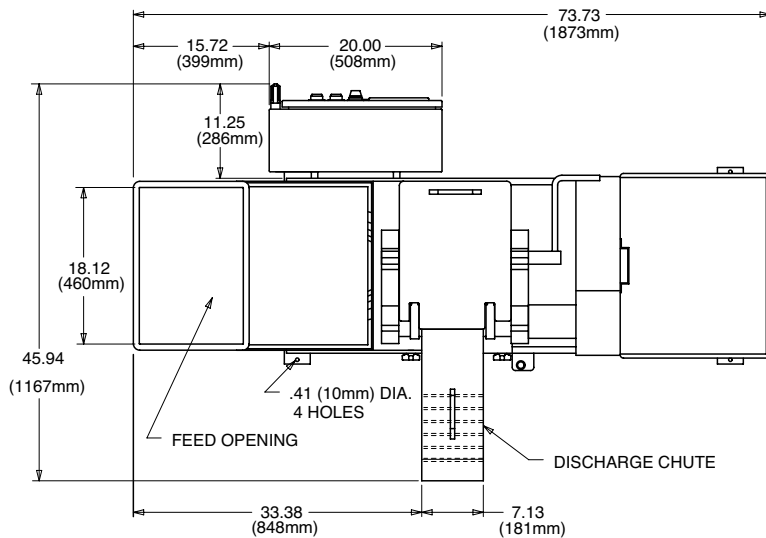

You Are Invited to Test Cut Your Product

Urschel Laboratories has a complete network of test facilities and experienced service and sales representatives around the world ready to work for you on any size reduction application. Contact your local Urschel Laboratories' representative to schedule a comprehensive, no-obligation test today at www.urschel.com.



URSCHEL
LABORATORIES INCORPORATED
 The Global Leader in Food Cutting Technology
www.urschel.com | ✉ info@urschel.com