

Model CE25 Case Erector



Robust, Compact Case Erector at Speeds up to 25 CPM.

Pearson's CE25 Case Erector is an innovative new case erector for erecting and bottom sealing RSC, HSC and RSC with integral divider cases with tape or hot melt adhesive at speeds of 25 cases per minute. The CE25 is a combination of Pearson's proven concepts with new technology, resulting in a machine that offers the highest reliability in its class. The CE25 features an ergonomically friendly, powered horizontal case magazine. With a vertical case presentation and compact footprint, the CE25 is ideal for limited floor space applications.

The CE25-T mechanically advances cases in the magazine to the pick-off. Once a case is picked, it is advanced into the feed rollers. For case setup, opposing vacuum cups engage the case and erect it. The case is advanced through the machine with Pearson's Integrated Chain Guide System (patent pending), the bottom flaps are closed using pneumatic actuators and tape or hot melt adhesive is applied. The case is discharged from the

machine in the vertical, upright position.

The CE25's offer the following features:

- **Allen-Bradley® PLC**
- **Allen-Bradley® Variable Frequency Drive**
- **Allen-Bradley® PanelView Operator Interface**
- **PackML compliant standard**
- **Nordson® Adhesive Melter**
- **Dekka® Pressure Sensitive Tape Head**
- **Banner® Photoelectrics**
- **Integrated Chain Guide System (patent pending)**
- **Electrically interlocked safety guard package**
- **Quick 5 minute changeover**
- **UL® Listed Control Panel**
- **Stainless steel construction optional**

Like all Pearson products, the CE25 is backed by Pearson's experienced factory professionals as well as one of the largest teams of PMMI certified regional service technicians in the industry, available 24-hours a day, 7-days a week - worldwide.

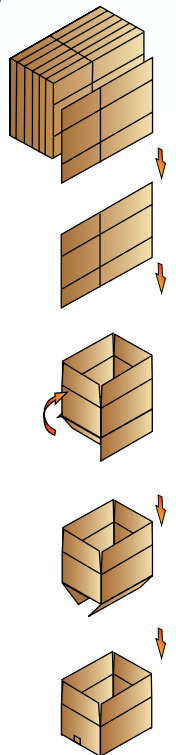

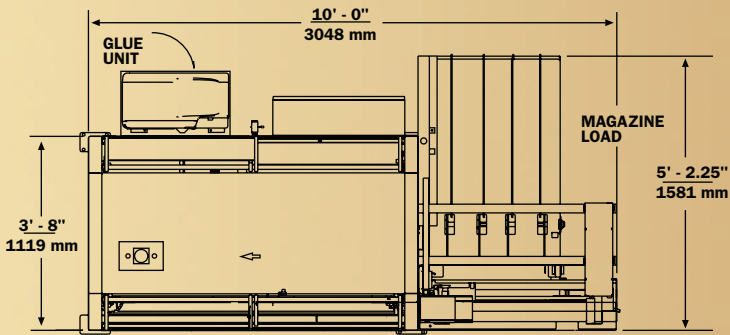

PLAN VIEW

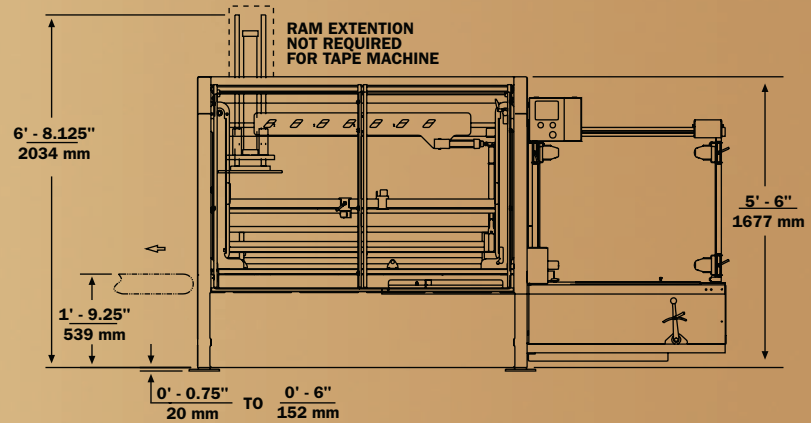

ELEVATION VIEW

UTILITY REQUIREMENTS CE25

CE25-T

Electrical:

230/460V, 3-phase,
60 Hz Std., 0.73 kVA

Pneumatic:

0.6827 SCF/Cycle @ 80 PSI
(0.0193 m³ /cycle @ 551.2 KPa)

Shipping Weight:

1,920 lbs. (872 kg)

CE25-G

Electrical:

230/460V, 3-phase,
60 Hz Std., 4.92 kVA

Pneumatic:

1.274 SCF/Cycle @ 80 PSI
(0.063 m³ /cycle @ 551.2 KPa)

Shipping Weight:

2,000 lbs. (908 kg)

ERECTED CASE SIZE RANGES

	LENGTH	WIDTH	CLOSED DEPTH	OPEN DEPTH*
CE25-T	8" - 24"	5" - 16"	3" - 18.5"	6" - 21"
CE25-G	203 - 610 mm	127 - 406 mm	76 - 470 mm	152 - 533 mm

KNOCKED-DOWN SIZES

	LENGTH	WIDTH	BOTTOM FLAP WIDTH
CE25-T	13" - 40"	8" - 29"	2.5" - 16"
CE25-G	330 - 1016 mm	203 - 737 mm	63.5 - 406 mm

* Top flaps open, bottom flaps closed. Please consult the factory with your project specifications.

MACHINE SPECIFICATIONS

	Length	Width	Height	Speed
CE25-T Pressure Sensitive Tape	10' - 0" 3048 mm	5' - 2.25" 1581 mm	5' - 6" 1677 mm	25 cpm
CE25-G Hot Melt Adhesive	10' - 0" 3048 mm	5' - 2.25" 1581 mm	6' - 8.125" 2034 mm	25 cpm

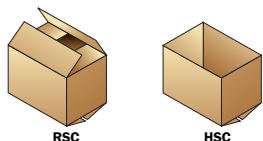

RSC w/
Integral
Divider

