



PBM VALVE SOLUTIONS

ACTUATORS

pneumatic rack and pinion



actuator features

Nominal Values:

Pressure rating of 120 psig (8 barg). Standard temperature range is -4°F to 185°F (-20°C to 85°C). High temperature range is -4°F to 302°F (-20°C; 150°C). Low temperature range is -40°F to 185°F (-40°C to 85°C). Pre-lubricated for life of actuator on assembly. Fully tested on manufacture 100%.

Rotation adjustment 0-90°

From MOD. 52 up to 200

- standard + or - 5° in both clockwise and counterclockwise direction by means of adjusting screws outside the internal air supply chambers
- standard visual position indicators

MOD. 270

- standard + or - 5° in counterclockwise direction by means of adjusting screws in the caps
- kit for + or - 5° in clockwise direction available on request

Die cast aluminum end caps

- Standard polyester powder coated
- Nickel plated upon request

Concentric spring sets

- Standard treatment phosphated
- High resistance and reliability
- Spring sets to suit different air pressure/torque requirements
- Long securing screws to allow safe dismantling for maintenance
- Same body dimensions for DA/SR versions

Assembling screws

- Stainless steel as standard

External connection

- Namur pinion mounting
- Namur solenoid valve mounting
- Bottom of pinion according to ISO 5211-DIN 3337
- Optional Beacon Indicator

Operating Pressure

Range - 40 psig to 120 psig (2.8 barg to 8 barg)

Operating Media

Clean, dry air or clean, dry, non-corrosive gas

Stroke

90 degrees standard

Steel pinion

- Nickel-plated for resistance to corrosion
- Stainless steel (optional) for corrosive environments
- Anti-blowout design

Body manufactured from extruded aluminum UNI 6060

- Hard-coat anodized as standard finish 45-50 (micron)
- Good wear resistance
- Bore finished to high standard to ensure low friction and long life

Piston guides

- Large contact area
- Self-lubricating materials
- Long life

Seals

- NBR standard
- Viton high temperature (optional)
- HNBR low temperature (optional)

Pistons

- Die cast aluminum
- Nickel-plating upon request

Twin rack and pinion design

- Constant torque output (double acting)
- compact design
- Balanced internal forces
- Robust design to ensure long life

Spring Return Actuators

Torque Ratings Double Acting Actuators

Actuator Model	Air pressure at actuator (psig)	
	60 psig	80 psig
	Constant Torque Output (in-lbs)	
PAVCL453D -- 0052	133	179
PAVCL453D -- 0063	238	321
PAVCL453D -- 0075	435	586
PAVCL453D -- 0085	629	851
PAVCL453D -- 0100	991	1,336
PAVCL453D -- 0115	1,640	2,210
PAVCL453D -- 0125	2,157	2,906
PAVCL453D -- 0140	3,013	4,018
PAVCL453D -- 0160	4,394	5,859
PAVCL453D -- 0200	8,239	10,981
PAVCL453D -- 0270	19,097	25,469

Actuator Model	Spring Set	Spring Torque Output (in-lbs)		Air Pressure at Actuator (psig)			
				60 psig		80 psig	
		Start	End	Start	End	Start	End
PAVCL253S -- 0052	03	66	46	80	47	N/A	N/A
PAVCL453S -- 0052	05	105	72	N/A	N/A	101	55
PAVCL253S -- 0063	03	128	71	149	79	N/A	N/A
PAVCL453S -- 0063	05	196	111	N/A	N/A	193	95
PAVCL253S -- 0075	03	249	133	275	137	N/A	N/A
PAVCL453S -- 0075	05	380	205	N/A	N/A	354	157
PAVCL253S -- 0085	03	361	215	387	211	N/A	N/A
PAVCL453S -- 0085	05	536	321	N/A	N/A	503	257
PAVCL253S -- 0100	03	564	318	628	329	N/A	N/A
PAVCL453S -- 0100	05	860	489	N/A	N/A	802	378
PAVCL253S -- 0115	03	957	538	1,044	541	N/A	N/A
PAVCL453S -- 0115	05	1,432	800	N/A	N/A	1,352	637
PAVCL253S -- 0125	03	1,313	718	1,351	640	N/A	N/A
PAVCL453S -- 0125	05	1,913	1,055	N/A	N/A	1,762	789
PAVCL253S -- 0140	03	1,958	1,036	1,910	856	N/A	N/A
PAVCL453S -- 0140	05	2,728	1,453	N/A	N/A	2,481	1,017
PAVCL253S -- 0160	04	2,841	1,770	2,447	1,350	N/A	N/A
PAVCL453S -- 0160	05	3,327	2,230	N/A	N/A	3,452	2,240
PAVCL253S -- 0200	04	4,699	3,124	4,788	3,080	N/A	N/A
PAVCL453S -- 0200	06	6,867	4,664	N/A	N/A	5,893	3,539
PAVCL253S -- 0270	05	12,549	8,044	11,495	6,884	N/A	N/A
PAVCL453S -- 0270	08	16,735	10,735	N/A	N/A	15,360	9,220

Weights & Operation Volumes

Actuator Model	Rotate CCW	Rotate CW	PAVC series
	Volume (cu.in.)	Volume (cu.in.)	Approx. wgt (lbs)
PAVCL453D -- 0052	6.1	7.9	2.47
PAVCL453S -- 0052	6.1	6.7	2.87
PAVCL453D -- 0063	12	14	3.66
PAVCL453S -- 0063	12	11.6	4.35
PAVCL453D -- 0075	22	27	6.13
PAVCL453S -- 0075	22	22	7.48
PAVCL453D -- 0085	31	39	8.60
PAVCL453S -- 0085	31	32	10.60
PAVCL453D -- 0100	48	61	12.13
PAVCL453S -- 0100	48	49	15.44
PAVCL453D -- 0115	79	104	19.51
PAVCL453S -- 0115	79	84	25.25
PAVCL453D -- 0125	99	135	23.81
PAVCL453S -- 0125	99	109	31.04
PAVCL453D -- 0140	138	193	35.94
PAVCL453S -- 0140	138	146	48.06
PAVCL453D -- 0160	220	306	47.95
PAVCL453S -- 0160	220	215	65.04
PAVCL453D -- 0200	348	644	81.57
PAVCL453S -- 0200	348	463	121.26
PAVCL453D -- 0270	915	1,086	182.23
PAVCL453S -- 0270	915	946	221.06

All published torque values are guaranteed minimum values.

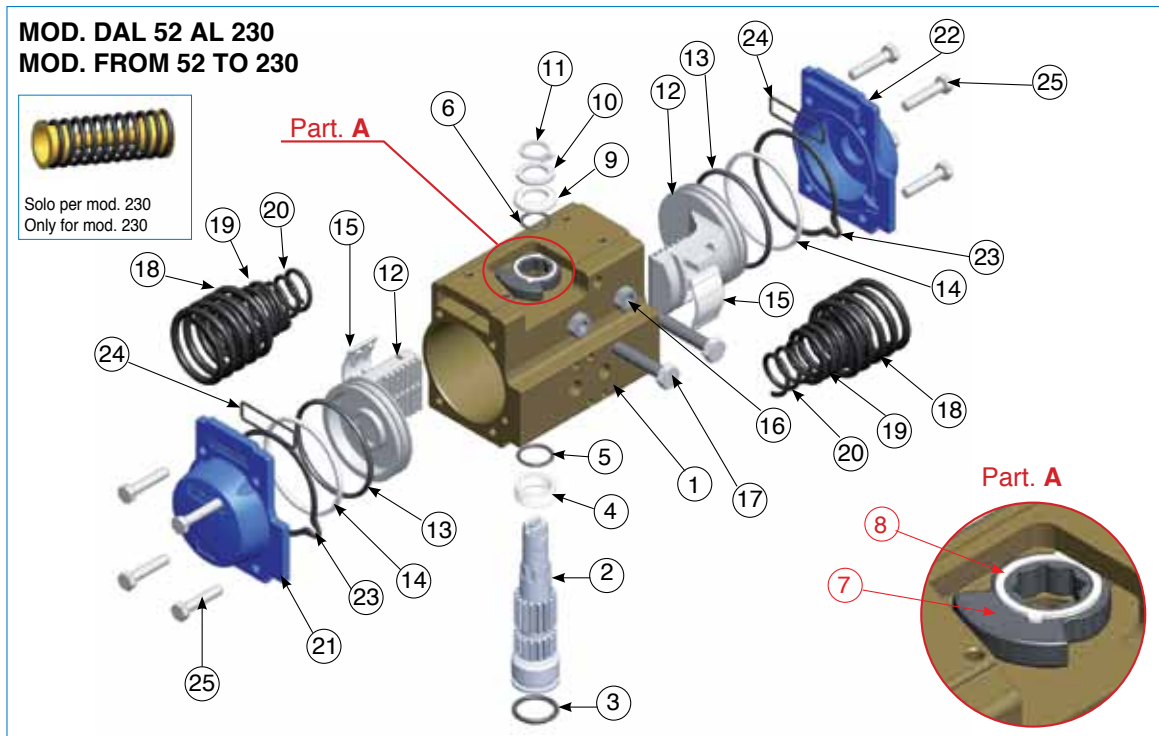

ITEM	DESCRIPTION	MATERIAL	TREATMENT	QUANTITY DA	QUANTITY SR
1	BODY	EXTRUDED ALUMINUM	HARD ANODIZED	1	1
2	ANTI-BLOWOUT PINION	STEEL	NICKEL PLATED	1	1
3*	O-RING	NBR		1	1
4*	SPACER RING	POM		1	1
5*	O-RING	NBR		1	1
6*	O-RING	NBR		1	1
7	CAM	STAINLESS STEEL		1	1
8	SPACER	POM		1	1
9*	SPACER	POM		1	1
10	WASHER	STAINLESS STEEL		1	1
11**	SNAP RING	STEEL	NICKEL PLATED	1	1
12	PISTON	DIE CAST ALUMINUM		2	2
13*	O-RING	NBR		2	2
14*	ANTIFRICTION RING	POM		2	2
15*	THRUST BLOCK	POM		2 [4]	2 [4]
16	STOP BOLT RETAINING NUT	STAINLESS STEEL		2	2
17	STOP BOLT	STAINLESS STEEL		2	2
18	EXTERNAL SPRING	STEEL	ZINC-PHOSPHATE	0	SEE SPRING SETTING AT PAGE 15
19***	CENTRAL SPRING	STEEL	ZINC-PHOSPHATE	0	
20	INTERNAL SPRING	STEEL	ZINC-PHOSPHATE	0	
21	LEFT END CAP	DIE CAST ALUMINUM	PAINTED	1	1
22	RIGHT END CAP	DIE CAST ALUMINUM	PAINTED	1	1
23	END CAP SEATS	NBR		2	2
24	O-RING	NBR		2	2
25	END CAP FIXING SCREW	STAINLESS STEEL		8	8

*Parts subject to wear ** Reinforced series DIN 471 - UNI 7436
Valid for mod. 140-160-180-200 only
***Only for mod. 160-180-200

ACTUATOR PARTS

MOD. 270

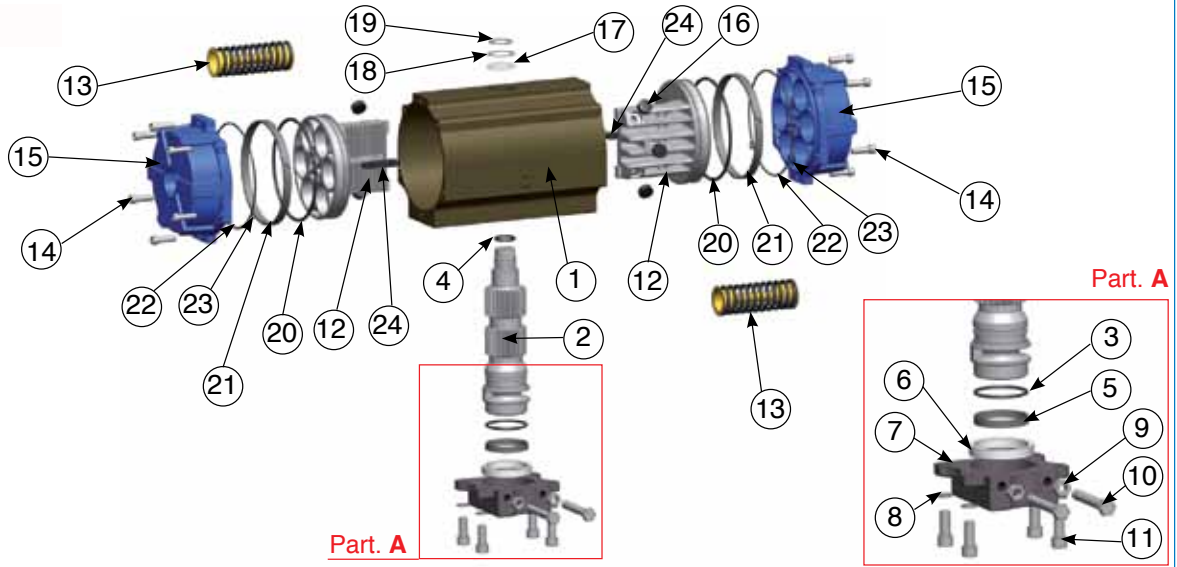

ITEM	DESCRIPTION	MATERIAL	TREATMENT	QUANTITY DA	QUANTITY SR
1	BODY	EXTRUDED ALUMINUM	HARD ANODIZED	1	1
2	ANTI-BLOWOUT PINION	STEEL	NICKEL PLATED	1	1
3*	O-RING	NBR		1	1
4*	O-RING	NBR		1	1
5*	ANTIFRICTION RING	PTFE 15% GRAPHITE		1	1
6*	ANTIFRICTION RING	PTFE		1	1
7	PLATE	GGG40	PAINTED	1	1
8	WASHER	STAINLESS STEEL		4	8
9	STOP BOLT RETAINING NUT	STAINLESS STEEL		2	2
10	STOP SCREW	STEEL	ZINC PLATED	2	2
11	FIXING SCREWS	STAINLESS STEEL		4	4
12	PISTON	DIE CAST ALUMINUM	ZINC-PHOSPHATE	2	2
13	PRECOMPRESSED SPRING	STEEL		0	See spring setting at page 15
14	END CAP FIXING SCREW	STAINLESS STEEL		12	12
15	END CAP	DIE CAST ALUMINUM	PAINTED	2	2
16*	THRUST BLOCK	POM		6	6
17*	SPACER RING	POM		1	1
18	PINION WASHER	STAINLESS STEEL		1	1
19	SNAP RING	STEEL	NICKEL PLATED	1	1
20*	O-RING	NBR		2	2
21*	ANTIFRICTION RING	PTFE 15% GRAPHITE		2	2
22	O-RING	NBR		2	2
23	O-RING	NBR		4	4
24	ANTI BLOWOUT KEY	POM		2	2

*Parts subject to wear

Dimensional Data for models 52 to 200

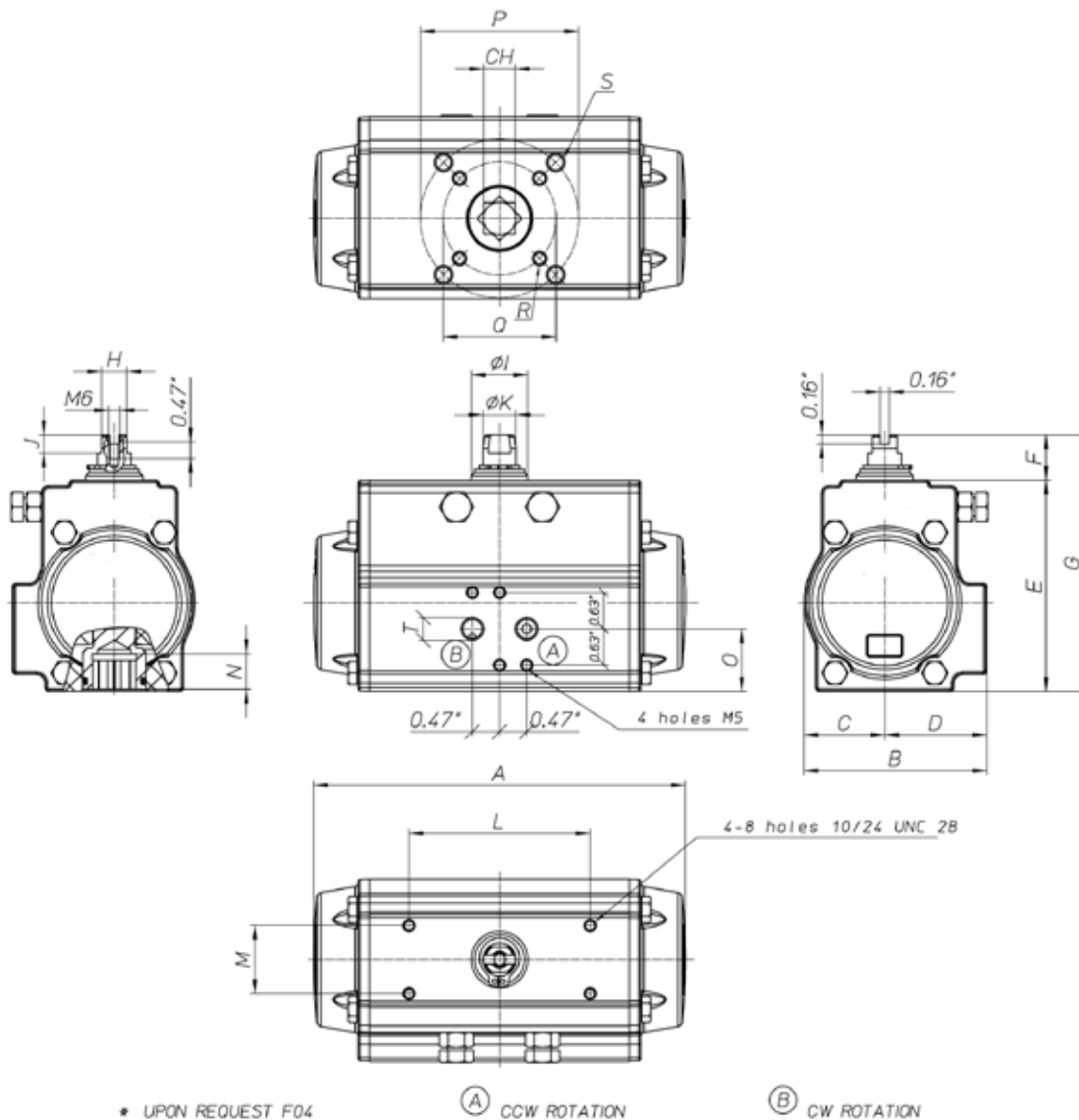

MOD.	DRILLING ISO 5211	CH	A	B	C	D	E	F	G	H	ØI	J	ØK	L	M	N	O	P	Q	R	S	T NPT
52	F03-F05	0.43	5.55	2.80	1.18	1.61	3.21	0.79	4.00	0.35	0.83	0.31	0.47	3.15	1.18	0.47	1.04	1.97	1.42	10-24 UNC 2BX0.29"	1/4-20 UNC 2BX0.35"	1/8"
63	F05-F07	0.55	6.46	3.17	1.4	1.77	3.66	0.79	4.45	0.43	0.98	0.31	0.59	3.15	1.18	0.63	1.08	2.76	1.97	1/4-20 UNC 2BX0.31"	5/16-18 UNC 2BX0.47"	1/8"
75	F05-F07	0.67	8.27	3.72	1.65	2.07	4.37	0.79	5.16	0.51	1.14	0.31	0.75	3.15	1.18	0.75	1.38	2.76	1.97	1/4-20 UNC 2BX0.31"	5/16-18 UNC 2BX0.47"	1/8"
85	F05-F07	0.67	9.47	4.17	1.87	2.3	4.92	0.79	5.71	0.59	1.38	0.31	0.87	3.15	1.18	0.75	1.65	2.76	1.97	1/4-20 UNC 2BX0.31"	5/16-18 UNC 2BX0.47"	1/8"
100	F07-F10	0.67	10.83	4.84	2.17	2.68	5.43	0.79	6.21	0.59	1.38	0.31	0.87	3.15	1.18	0.81	1.97	4.02	2.76	5/16-18 UNC 2BX0.31"	3/8-16 UNC 2BX0.55"	1/4"
115	F07-F10	0.87	13.11	5.39	2.52	2.87	6.39	1.18	7.57	0.87	1.93	0.55	1.26	5.12	1.18	0.95	1.97	4.02	2.76	5/16-18 UNC 2BX0.47"	3/8-16 UNC 2BX0.59"	1/4"
125	F07-F10	0.87	14.65	5.83	2.68	3.15	6.87	1.18	8.05	0.87	1.93	0.55	1.26	5.12	1.18	0.95	2.46	4.02	2.76	5/16-18 UNC 2BX0.47"	3/8-16 UNC 2BX0.59"	1/4"
140	F10-F12	1.06	17.13	6.46	3.01	3.44	7.76	1.18	8.94	0.94	1.93	0.63	1.38	5.12	1.18	1.14	2.80	4.92	4.02	3/8-16 UNC 2BX0.59"	1/2-13 UNC 2BX0.71"	1/4"
160	F10-F12	1.06	19.69	7.32	3.43	3.90	8.70	1.18	9.88	1.18	2.24	0.63	1.57	3.15/ 5.12	1.18	1.26	3.15	4.92	4.02	3/8-16 UNC 2BX0.55"	1/2-13 UNC 2BX0.67"	1/4"
200	F14	1.42	22.78	8.54	4.25	4.29	10.94	1.18	12.13	1.42	2.64	0.63	1.97	3.15/ 5.12	1.18	1.46	3.07	5.51	/	/	5/8-11 UNC 2BX0.94"	1/4"

Dimensions for model 270

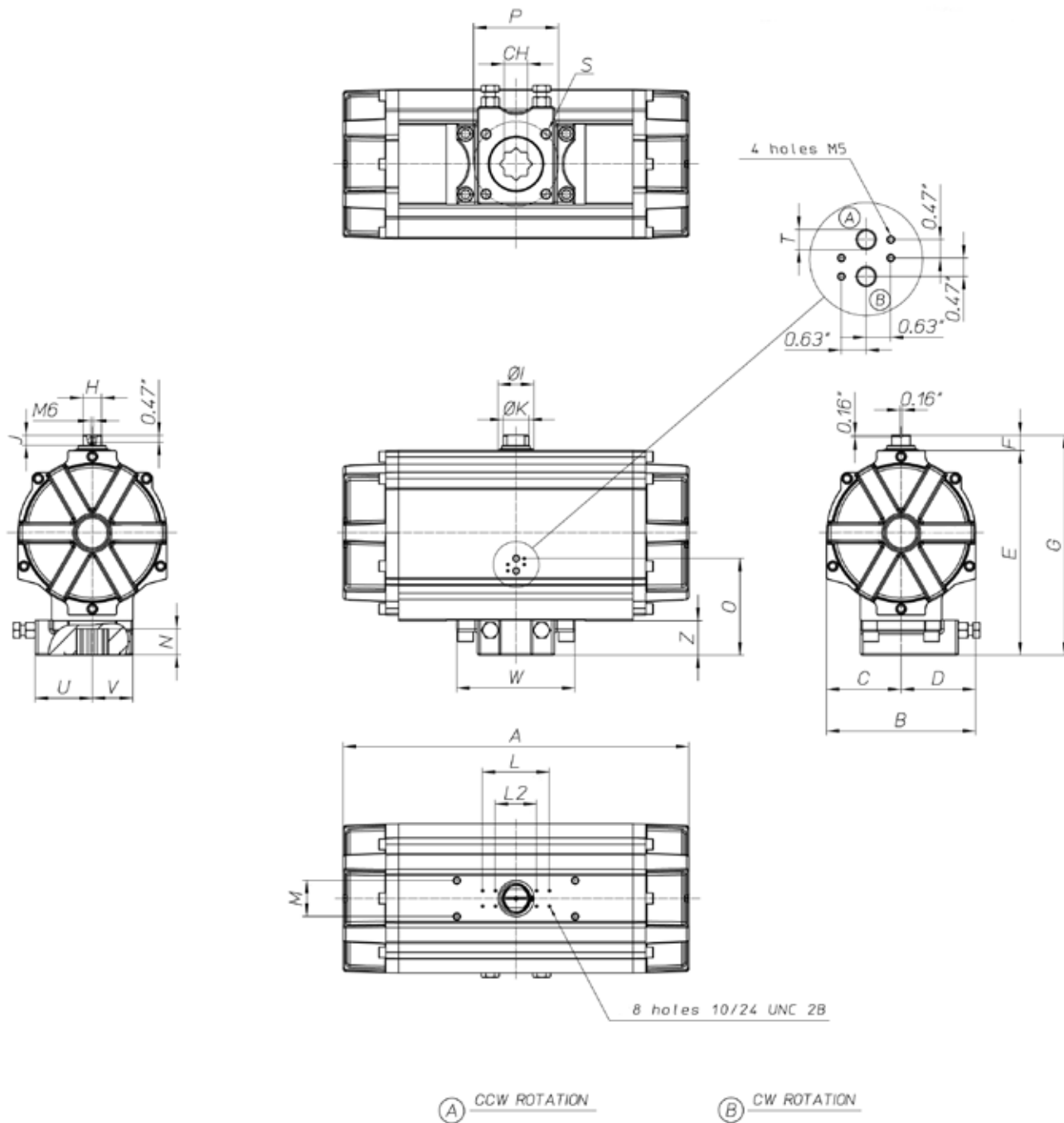

MOD.	DRILLING ISO 5211	CH	A	B	C	D	E	F	G	H	ØI	J	ØK	L	L2	M	N	O	P	S	T NPT	U	V	W	Z
270	F16	1.81	26.46	11.42	5.71	5.71	15.71	1.18	16.89	1.42	2.76	0.79	1.97	5.12	3.15	1.18	1.97	7.40	6.50	3/4-10 UNC 2B X 1.18"	1/4"	4.37	3.11	9.06	2.68



United States • Canada • Brazil • Mexico • Chile • Australia
United Kingdom • Germany • Sweden • Spain • Belgium • France
Ireland • Switzerland • Austria • The Netherlands
India • Taiwan • China • Thailand • Singapore

Visit PBM online at
www.pbmvalve.com
to find the PBM domestic or international representative near you.



PBM, Inc.
1070 Sandy Hill Road • Irwin, PA 15642
800-967-4PBM • 724-863-0550 • Fax: 724-864-9255
www.pbmvalve.com • Email: info@pbmvalve.com



LT-23A 03/12